



Technical Journal

TITLE:

Test schedule for vehicle speed dependent vibrations at highway speeds

REF NO: TJ 20803.11.0	ISSUING DEPARTMENT: Technical Service	CAR MARKET: United States and Canada	
PARTNER: 3 US 7510 Volvo Car USA		ISSUE DATE: 2016-10-13	STATUS DATE: 2016-10-18
FUNC GROUP: 2185	FUNC DESC: Engine undershield	Page 1 of 10	

“Right first time in Time”

Attachment

File Name	File Size
Fault tracing schedule.doc	0.4824 MB
T9379EN01.docx	0.0435 MB

Vehicle Type

Type	Eng	Eng Desc	Sales	Body	Gear	Steer	Model Year	Plant	Chassis range	Struc Week Range
124							2007-2017		0000850-0200260	200620-201614
134							2011-9999		0000194-9999999	201020-999999
135							2008-2017		0000395-0377263	200720-201616
136							2008-2017		0000395-0274097	200720-201619
144							2009-9999		0000001-0999999	200845-999952
155							2011-9999		0000100-9999999	201035-999999
157							2015-9999		0000001-0999999	201450-999952
234							2017-9999		-	201617-999952
235							2017-9999		-	201624-999952
256							2015-9999		0000001-0999999	201505-999952
275							2007-9999		0328000-9999999	200620-999999
285							2007-9999		0617000-9999999	200620-999999
295							2007-9999		0254000-9999999	200620-999999
384							2007-9999		0600000-9999999	200620-999999
5XX							2007-9999		0010000-9999999	200620-999999



CSC Customer Symptom Codes

Code	Description
C4	Complete vehicle/Unusual noise/While driving
F3	Complete vehicle/Unusual noise/During acceleration
F6	Complete vehicle/Unusual noise/During deceleration
8N	Driving/Unusual noise/Unsure when/at all times
F1	Driving/Unusual noise/At engine shut off
F2	Driving/Unusual noise/During acceleration
ZE	Idling/Unusual noise
XB	Exhaust system/Rattle/rumble
WX	Engine cooling fan (FC)/Unusual noise
F4	Clutch/Unusual noise/Noise from engine compartment
C3	Automatic transmission/Unusual noise
F5	Gear selector/Unusual noise
C6	Manual transmission/Unusual noise
D2	Front/rear axle/Unusual noise
WV	Suspension/Clicking/clonking noise/At start/stop
WY	Suspension/Clicking/clonking noise/Unsure when/at all times
X1	Suspension/Unusual noise
H3	Steering wheel/Squeak/rattle/Steering column/wheel
H4	Steering/Unusual noise/Unsure when/at all times
X8	Steering/Unusual noise/At full turn
E7	Suspension/Unusual noise
WZ	Suspension/Clicking/clonking noise
8J	Shock absorption/Unusual noise
1M	Wheels, tires, hubs/Unusual noise/Front
1N	Wheels, tires, hubs/Unusual noise/Rear
V6	Complete vehicle/Vibration/When driving below 45 MPH
V7	Complete vehicle/Vibration/When driving above 45 MPH
NY	Automatic transmission/Vibration
V9	Gear selector/Vibration
8A	Manual transmission/Vibration
W2	Front/rear axle/Vibration/shake
V2	Steering wheel/Vibration/shimmy/When driving above 45 mph
W3	Steering wheel/Vibration/shimmy/When driving below 45 mph
X7	Steering wheel/Vibration/shimmy/At idle
V1	Tires/Vibration/out of round

VST Operation Number



DTC Diagnostic Trouble Codes

Rows beginning with * are modified

Note! If using a printed copy of this Technical Journal, first check for the latest online version.

Text

DESCRIPTION:

* Updated attachment “Fault tracing schedule”

In case of a complaint of Noise, Vibration or Harshness, NVH, and you need help from THD, some “tools” have been created to help you to do a better and more precise fault tracing.

1. Question form to fill in and attach along with a vehicle report for faster support
2. Guideline to help you to sort out NVH related problems.

SERVICE:

N/A

VEHICLE REPORT:

Yes, together with a complete filled in attachment, included in this journal.

The attachment **MUST** be in English when sending it into THD.

Use always function group 2185.

To view TJ attachment continue to next page. This TJ has two attachments.



Volvo Car Customer Service

TJ Instruction T20803

Title	Fault tracing schedule regarding vibrations at highway speeds.	Page:	1 (4)
Action	Fault tracing	Operation number:	

Issue	Date	Cause
1	2015-03	Update

Affected vehicles

Year	Model	Engine	Transmission	Steering	Chassis number
All	2015-		AWD		

Test schedule for vehicle vibrations at highway speeds

1.

If none of the tests below help, submit a report to customer service.

2.

To verify whether the vibrations are vehicle speed dependent or engine speed dependent, follow the fault tracing below.

1. Start by checking in which gear(s) and at what engine speed range the customer experiences the problem. Road surface and surrounding temperature are of importance.
2. Test in another gear at the same vehicle speed.

Same engine speed at different gears → Engine speed related problem.

Same vehicle speed at different gears → Vehicle speed related problem.

Test schedule for vehicle speed dependent vibrations at highway speeds.

Following test procedure is very important to carry out in proper order. First analyse the wheel contributions and then the AWD system contribution (if included in car spec.).

1, Wheel generated vibrations (43mph-93mph).

Always drive the car at least 15 minutes before evaluation to avoid “flat spot” contribution.

3.

Root cause analysis of the wheels

1. Check the status of the wheels regarding wear, damage and dirt.
2. Rebalance the wheels.
3. Test drive vehicle with 1,5bar in tire pressure. If vibration level decreases root cause most probably is non uniform wheels. Uniformity contribution decreases with lower tyre pressure. **Note, only for testing!**
4. Test drive (if possible) a vehicle of the same specification. If that vehicle does not show same behaviour, transfer the wheels to the problem car.
Important! Install the wheels in the same wheel positions. Test drive the car with the “transferred” wheels at the same driving conditions.

If none of the above actions lower the vibration levels in vehicle continue with root cause analysis of the AWD system or drive shafts (if no AWD spec.).

2, Front drive shaft vibrations (37mph-78mph).

Remove DEM fuse and judge if the vibrations increases / decreases at moderate acceleration at 3rd gear. If the vibration levels are increased the root cause most probably is imbalance of front drive shafts. Replace both drive shafts and RHS Bracket (31401993) and do a new test drive.

3, AWD generated vibrations (worst at 70mph-78 mph)

If the wheel and drive shafts contribution to the vibration levels are negligible, next step is a fault tracing of the

AWD system (often worst at 70mph-78 mph). Test drive after each step.

Root cause analysis of AWD system

If the wheel contributions of the vibration levels are negligible, continue with fault tracing of the AWD system (often vibration peak at 70mph-78 mph). **Test drive after each step.**

1. Remove the propeller shaft. If OK, replace propeller shaft
2. Remove DEM fuse, eliminates contribution from AOC pump If OK, replace AOC pump
3. Order a new companion flange (31259419) and mount (without torsional damper)
4. Replace AOC
5. Replace final gear

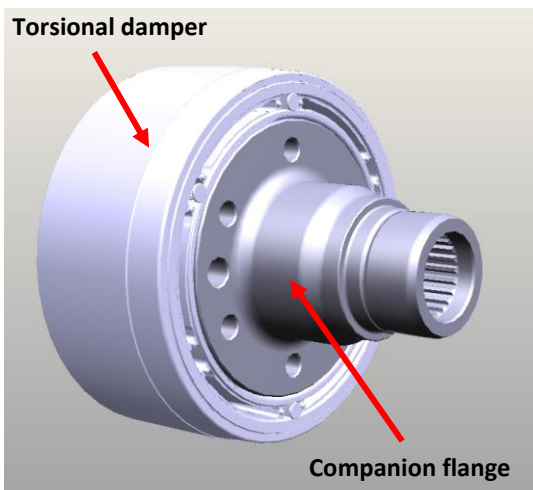
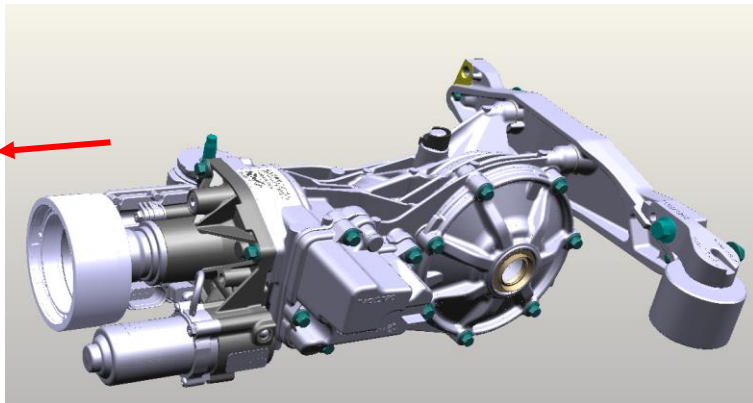



Volvo Car Customer Service

TJ Instruction T9379

Title	Fault-tracing schedule NVH	Page:	1 (3)
Action	Test protocol	Operation number:	

Issue	Date	Cause
1	2015-02	First issue

Affected vehicles

Year	Model	Engine	Transmission	Steering	Chassis number
All	All				

Special tools

Description	Tool number
CHASSIS-EAR	9814108

Relevant vehicle

VIN	Model	Year	Engine	Transmission	Steering

1.

Note! ALWAYS start by inflating the tyres to **comfort** pressure.

Note! ALWAYS test drive with the customer and allow the customer to describe the interference.

Note! ALWAYS record the noise and include in the report.

2.

Questions to be filled in with the customer

1: When was the interference noticed for the first time?

Odometer: _____ KM

Odometer: _____ Miles

2: What type of interference?

- Noise
 Vibration

2:2 Experienced in?

- The steering wheel
 Floor
 Seats: Front
 Seats: Rear
 Seats: Third row (XC90)

3: When does the interference occur?

- Stationary vehicle during "revving engine"
 uphill
 Downhill
 Whilst driving
 Rolling vehicle
 Acceleration
 Deceleration

Speed: _____ km/h

Speed: _____ mph

Engine speed: _____ Rpm

Which gear(s)? _____

- Recurring Sporadic

4: Weather conditions when the interference occurs?

Outdoor temperature: _____ °C

- Dry road
 Wet road

5: What type of road surface?

6: Vehicle status?

- Cold
 Hot

Further questions

7: Engine temperature? _____°C

8: If there is a sound file, where is it recorded?

- In the passenger compartment, front seat
- In the passenger compartment, rear seat
- Under the vehicle
- In the engine compartment

Describe at what second the noise is heard. _____Sec?

9: Has Chassis-ear, 9814108, been used for fault tracing?

- Yes
- No

10: What type of recording equipment has been used? _____

11: Space for further comments.
