

Automotive Division
Restraints

Technical Service Bulletin
No. TS 01 51816

May 18, 2016
REVISED August 24, 2016

DAMAGE TO FRONT SIDE AIRBAG HARNESS Special Warranty Extension ZH

Affected Departments: Management, Service, Parts, Warranty

Affected Models: Certain 2005 - 2008 Forenza and Reno Vehicles (RQ)

Revision 8/24/2016: Procedure Clarification, DTC B1379 and Seat Height Adjuster provision added.

Special Policy Adjustment

This special coverage covers the condition described above for a period of 12 years or 150,000 miles (240,000 km), whichever occurs first, from the date the vehicle was originally placed in service, regardless of ownership.

What is the problem?

On some model-year 2005 – 2008 Suzuki Forenza and Suzuki Reno vehicles there may be a condition where the airbag readiness lamp may illuminate due to damage to the side airbag (SAB) wiring harness. Contact between the airbag wire harness and the seat frame or the set recliner hinge could cause the airbag wire harness to become damaged, creating a possible short-circuit. If this occurs, the airbag readiness lamp may illuminate in the instrument panel. If the airbag readiness lamp is ignored and the condition is not corrected, there is the potential for the airbag to deploy within 3 seconds of an ignition cycle, or the side airbag could fail to deploy in a crash.

What is Suzuki Motor of America, Inc., going to do to solve this concern?

Suzuki Service Providers are to verify if Supplemental Restraint System (SRS) DTCs B1380, B1384 or B1379 are stored as Current or History. Depending on the DTC present, specific instructions are provided in this bulletin to repair and prevent the DTC from reoccurring. In addition to inspecting for DTCs, the Suzuki Service Provider Technician is to inspect the driver's seat height adjuster assembly. If either front seat side airbag has deployed without an accident, specific repair instructions are also provided in this bulletin.

Repair Procedure:

The repair procedure is divided into two repair scenarios:

- 1) Repair for vehicles without an unintended deployment of the seat side airbag
- 2) Vehicles with an unintended seat side airbag deployment

Refer to the flow charts on the next two pages for inspection, repair and processing assistance.

Forenza / Reno Seat Side Airbag No Deployment

Using the Tech 2, check the SRS for DTCs. Write down all SRS DTCs either Current or History

Check the driver's seat height adjuster for damage. Refer to Pg. 5 for instructions.
Is there damage to the seat height adjuster and/or B1380, and/or B1379 and/or B1384 set Current or History?

NO

Review any other non-ZH Warranty Extension airbag DTCs with the vehicle owner for repair options.

YES

Record radio pre-set stations.

Disable the SRS System. Refer to the Suzuki Pit Stop Plus Service Repair Manual.

If the driver's seat height adjuster is broken, replace the height adjuster. Refer to Pg. 8 for instructions.
If DTCs recorded in Step 1 are either B1380, B1384 or B1379, proceed to the affected seat (B1379 & B1380 are driver's, B1384 is passenger)

Inspect the SAB harness for damage. Refer to Pg. 6 for possible damage locations.

Perform the SAB harness repair. Refer to Pg. 10 for instructions.

Perform the SAB harness re-routing. Refer to Pg. 15 for instructions.

Enable the SRS System. Refer to Suzuki Pit Stop Plus.

Clear DTC B1380 and /or B1379 and/or B1384. Did DTCs clear?

NO

Record all SRS DTCs. Replace the SDM. Refer to the Suzuki Pit Stop Plus Service Repair Manual. After installation, record any non-ZH Warranty Extension airbag DTCs.

YES

Re-set the radio pre-set stations.

Review any non-ZH Warranty Extension airbag DTCs with the vehicle owner for repair options.

Repairs are completed.

Forenza / Reno Seat Side Airbag With Deployment

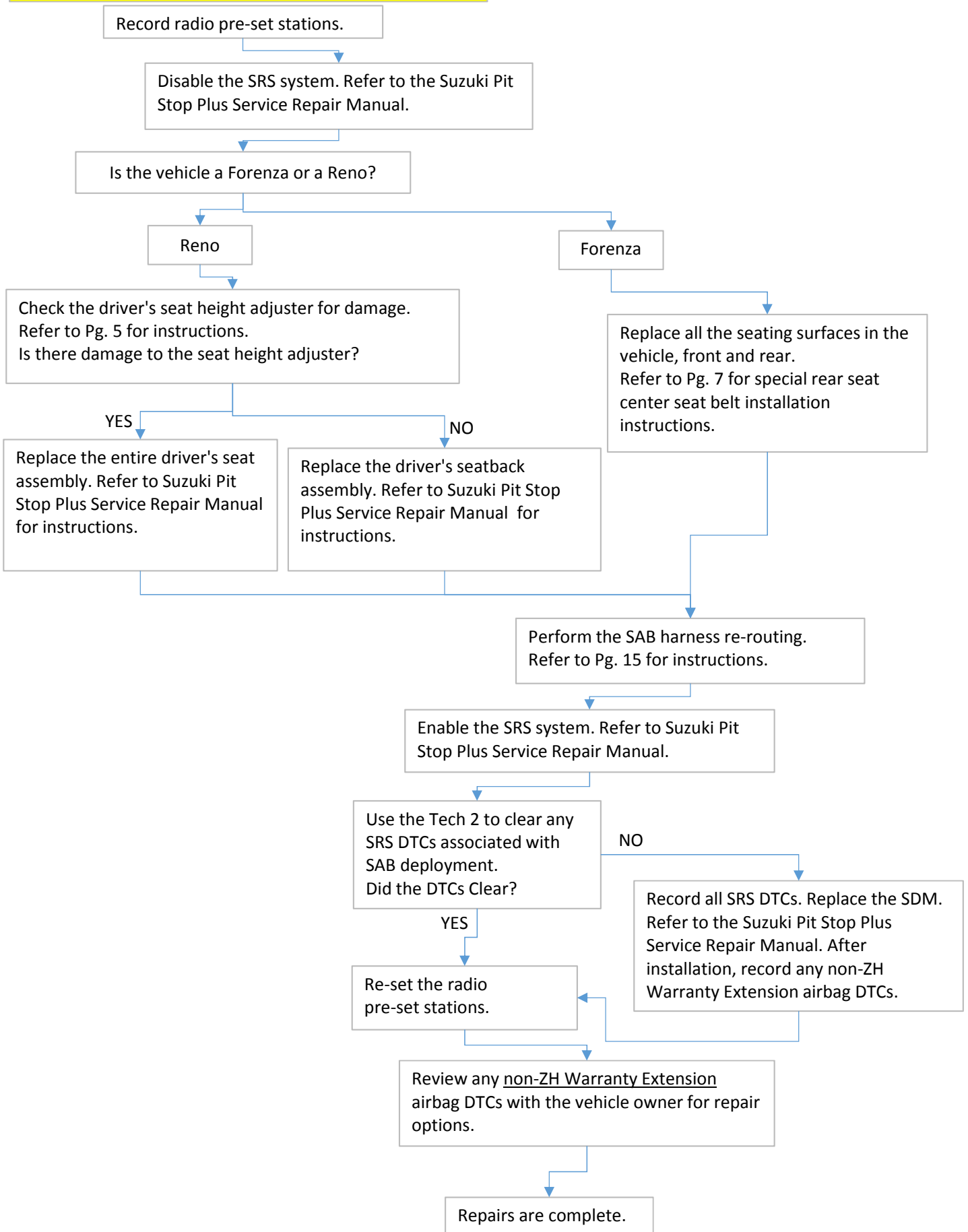

Safety Notices:

⚠ WARNING

The sensing and diagnostic module (SDM) can maintain sufficient voltage to deploy the airbags and pre-tensioners for 1 minute after the ignition is OFF and the fuse has been removed. If the airbags and pre-tensioners are not disconnected, do not begin service until 1 minute has passed after disconnecting power to SDM. If the airbags are disconnected, service can be done immediately without waiting for a 1-minute time period to expire. Failure to temporarily disable the supplemental inflatable restraints (SIR) during service can result in unexpected deployment, personal injury and unnecessary SIR repairs.

⚠ WARNING

During service procedure, be very careful when handling the SDM. Never strike or jar the SDM. Never power the SIR when the SDM is not rigidly attached to the vehicle. All SDM mounting bolts must be carefully tightened and the arrow on the SDM must be point toward the front of the vehicle to ensure proper operation of the SIR. The SDM could be activated if it is powered when it is not rigidly attached to the vehicle, resulting in unexpected deployment and possible injury.

Special Notes and Information:

NOTE 1

DTC B1380 is for a driver's seat side airbag harness short to ground.

DTC B1384 is for a passenger's seat side airbag harness short to ground.

DTC B1379 is for a driver's seat side airbag harness low resistance.

NOTE 2

*Refer to the flow chart **Seat Side Airbag With Deployed** on page 3. If either front seat side airbag has deployed without impact, refer to **Seat Fabric Color Identification** on page 16 and refer to the **SAB Harness Routing** on page 15 for repair direction.*

NOTE 3

Some vehicle repairs requiring new rear seats will require special seat belt installation. Refer to instructions provided on page 7.

NOTE 4

If the seat height adjuster is not damaged and/or DTC B1380, B1379 or B1384 is not stored, no additional action for this warranty extension is required. If there are other SRS DTCs, review the repair options with the vehicle owner.

Service Procedure:

Procedure #1 — For vehicles without a seat side Airbag deployment – proceed below with step 1.

Procedure #2 — For vehicles with a seat side airbag deployment – go to page 6, Procedure #2.

- 1) Using a scan tool, check for supplemental restraint system (SRS) for diagnostic trouble codes (DTCs). Write down all the SRS DTCs regardless if Current or History.
- 2) Check the driver's side seat height adjuster for damage. Refer to **Seat Height Adjuster Inspection** on page 5. If the seat height adjuster is damaged and/or DTCs B1379, B1380 or B1384 are stored, proceed to step 3. If no seat height adjuster damage or DTC B1379, B1380 or B1384 refer to NOTE 4 above.

Seat Height Adjuster Inspection:

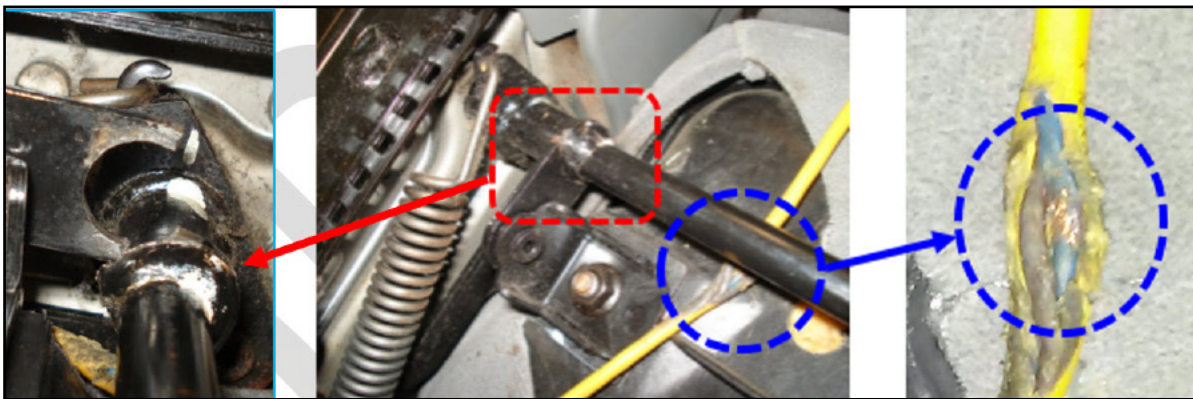
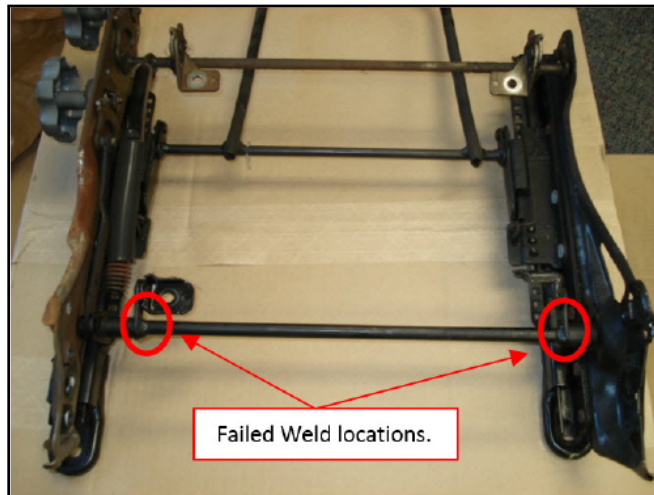

- 3) Record the customer's radio pre-set stations for reprogramming later.
- 4) Disable the SIR system. Refer to ***Disabling the Supplemental Inflatable Restraints (SIR)*** in Suzuki Pit Stop PLUS Service Repair Manual.
- 5) If the driver's seat adjuster is damaged, replace the seat height adjuster. Refer to ***Seat Height Adjuster Replacement Procedure*** on page 8 and ***Front Bucket Seat Removal and Installation*** in the Suzuki Pit Stop PLUS Service Repair Manual. Inspect the SAB harness for damage — refer to SAB Harness Damage Inspection on pages 5-6.
- 6) If SRS DTCs B1380, B1379 or B1384 were recorded in step 2, proceed to the ***SAB Harness Damage Inspection*** on pages 6.

SAB Harness Inspection:

Damage from a failed Seat Height Adjuster

Damage to the SAB harness may be as severe as pictured or there may be only minor scuffing of the SAB harness yellow insulation covering.

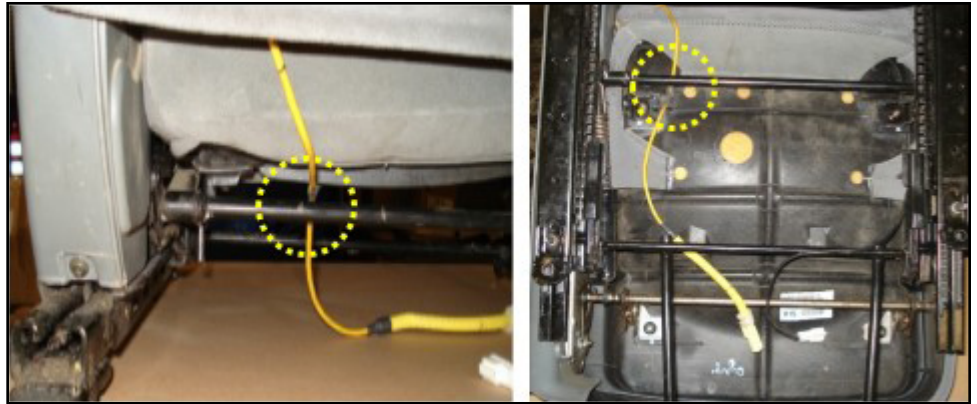

Damage from the Seat Recliner Hinge

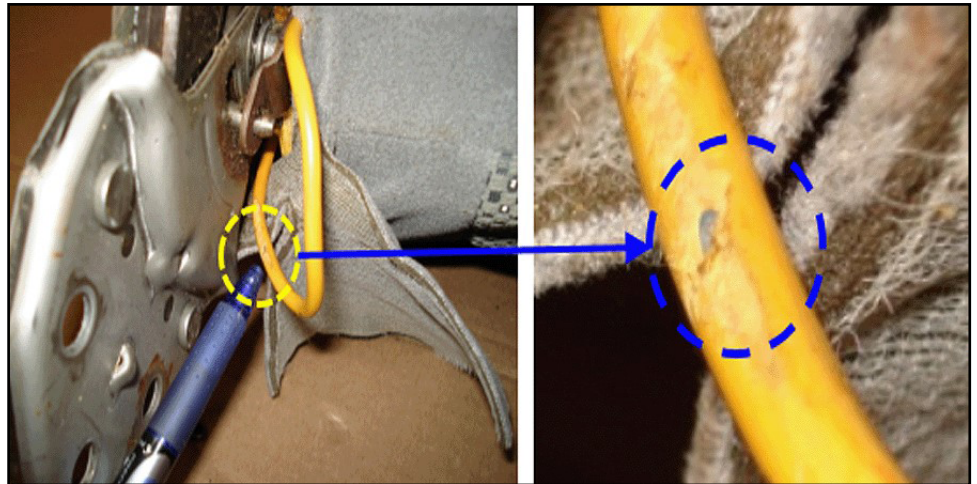

- 7) Repair the SAB harness damage. See **Front Seat Wiring Harness Repair Procedure** on page 10.
- 8) Reinstall the seat in the vehicle. Refer to **Front Bucket Seat Removal and Installation** in the Suzuki Pit Stop PLUS Service Repair Manual.
- 9) Route the SAB harness per the instruction below. See **SAB Harness Routing** on page 15.
- 10) Enable the SIR system. Refer to **Enabling the Supplemental Inflatable Restraints (SIR)** in the Suzuki Pit Stop PLUS Service Repair Manual.
- 11) Using the scan tool, clear DTCs B1380, B1384 or B1379. If the DTCs cannot be cleared, replace the sensing and diagnostic module (SDM) with a new one. **Refer to Sensing and Diagnostic Module (SDM)** in the Suzuki Pit Stop PLUS Service Repair Manual.
- 12) Re-set the radio preset stations recorded in step 3 above.
- 13) Repairs are complete for this warranty extension.

Procedure #2 – For vehicles with a seat side airbag unintended deployment.

- 1) Forenza and Reno: Record the customers pre-set radio stations.
- 2) Forenza and Reno: Disable the supplemental restraint system (SRS). Refer to **Disabling the Supplemental Inflatable Restraint (SIR)** in the Suzuki Pit Stop Plus Service Repair Manual.
- 3) Forenza and Reno: Determine if the vehicle is a Forenza or Reno. For Reno vehicles, proceed to step 4. For Forenza vehicles, proceed to step 6.
- 4) Reno Only: If the driver's seat side airbag is deployed, check the driver's side seat height adjuster for damage. Refer to **Seat Height Adjuster Inspection** on page 5 above. If the seat height adjuster is damaged, replace the complete driver's seat assembly. If the seat height adjuster is not damaged, proceed to step 5.

- 5) Reno Only: Replace the seatback for the driver's or passenger seat that has the deployed airbag. Refer to **Front Seatback Removal and Installation** in the Suzuki Pit Stop Plus Service Repair Manual. To be certain the seat fabric on the replacement seatback matches the seat fabric for the other seat in the car, see **Seat Fabric Color Identification** on page 16 below. Once this step is completed, skip to step 8.
- 6) Forenza Only: With a driver or passenger seat side airbag deployment, all the seats in the vehicle will require replacement. The various seat fabric colors and patterns used in the Forenza are no longer available — only the Split Gray fabric is available for this repair. Refer to the **Seat Fabric Color Identification** on page 16 for confirmation of seat fabric. To replace all the seats in the car, refer to the Suzuki Pit Stop Plus Service Repair Manual for installation procedures.
- 7) Forenza Only: Seat belt installation for the Forenza rear seat, center seat belt occupant, will require the following special installation process. Refer to the picture and text below.

Forenza Only: On the replacement rear seat, the center passenger seat belt extends from the center of the seatback. When the seat back is installed, pull the seat belt out of the seat back approximately 203 - 254mm (8 - 10 in) and cut the seat belt webbing. Allow the remaining seat belt to retract into the seat. All the original installed seat belts will be reused.



- 8) Forenza and Reno: Route the SAB per the instruction. See **SAB Harness Routing** on page 15.
- 9) Forenza and Reno: Enable the SIR system. Refer to **Enabling the Supplemental Inflatable Restraint (SIR)** in the Suzuki Pit Stop PLUS Service Repair Manual.
- 10) Forenza and Reno: Using the scan tool, clear DTCs B1380, B1384 or B1379 DTCs. If the DTCs cannot be cleared, replace the sensing and diagnostic module (SDM) with a new one. Refer to **Sensing and Diagnostic Module (SDM)** in the Suzuki Pit Stop PLUS Service Repair Manual.
- 11) Forenza and Reno: Re-set the radio preset stations recorded in step 1 above.
- 12) Repairs are complete for this warranty extension.

Seat Height Adjuster Replacement Procedure

Removal & Installation Procedure

- 1) Remove the seat height adjuster knobs by removing the horseshoe Retaining Clip and pulling on the knob.

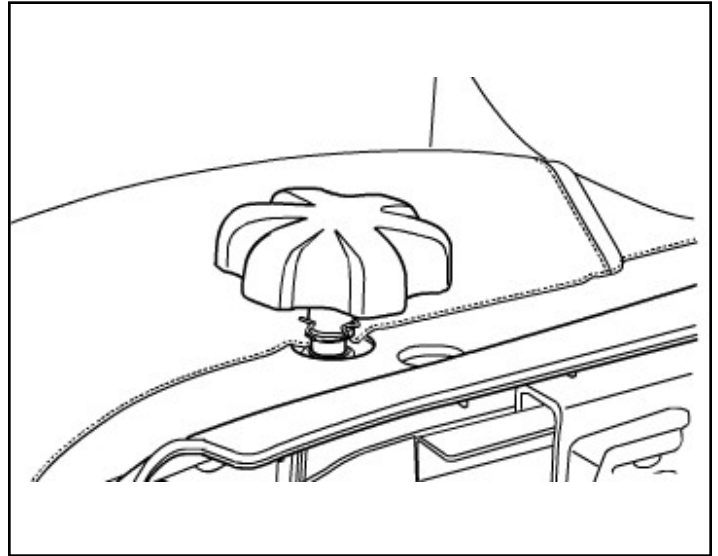

- 2) Remove the seat side trim.

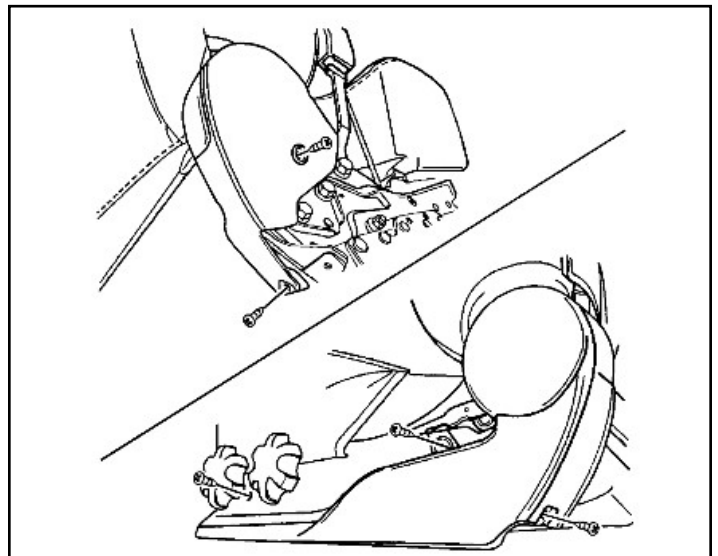

- 3) Remove the seatback recliner hinge bolts at the height adjuster and remove the seatback.

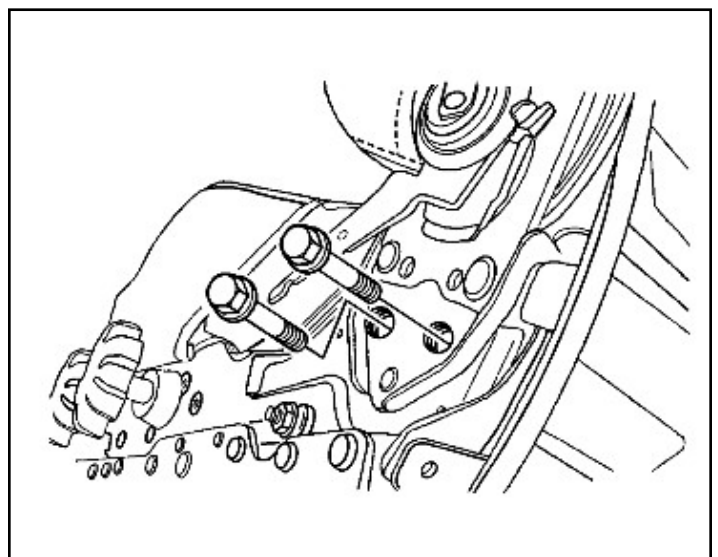

- 4) Remove the seat cushion mounting nuts.
- 5) Remove the damaged seat height adjuster assembly from the seat cushion.
- 6) Install the new seat height adjuster assembly to the seat cushion.
- 7) Install the seat cushion mounting nuts and tighten to 12 N·m (9 lbf-ft).
- 8) Install the seatback onto the height adjuster/seat cushion.

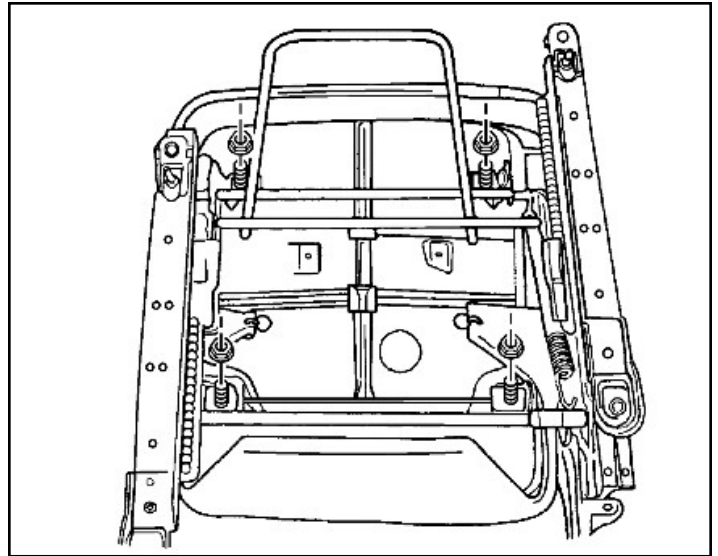

- 9) Install the seatback recliner hinge bolts and tighten to 45 N·m (33 lbf-ft).

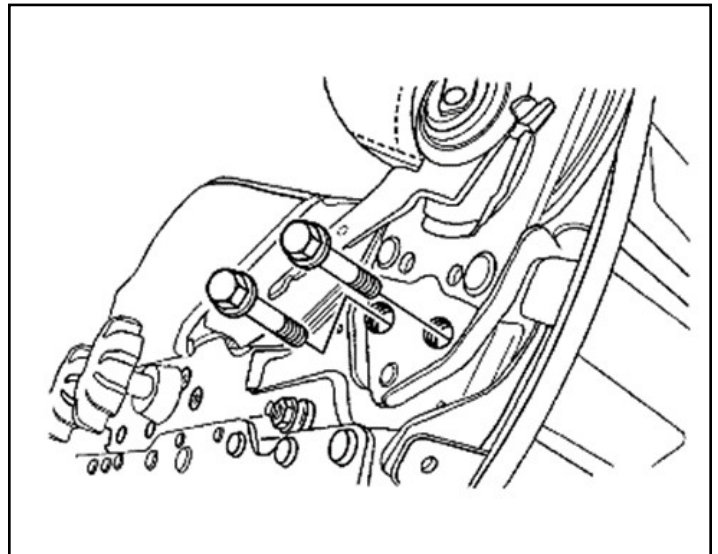

- 10) Install the seat side trim to its original position.

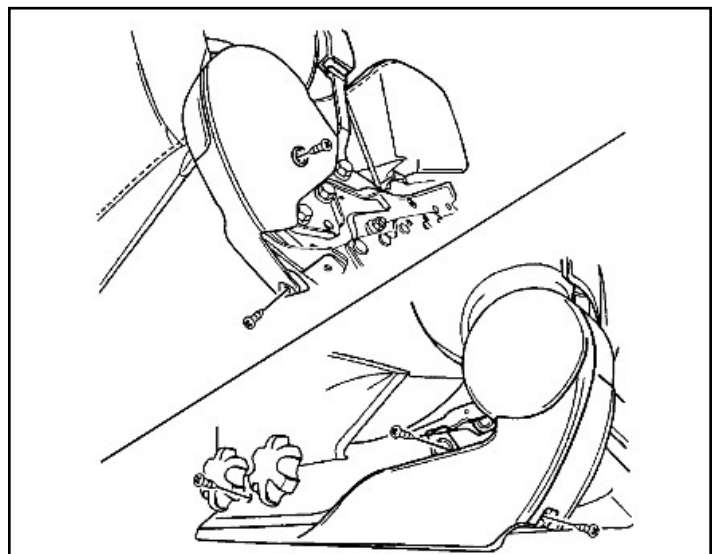

- 11) Install the seat height adjustment knobs by installing the horseshoe retaining clip on the knobs and pushing the knobs into place.

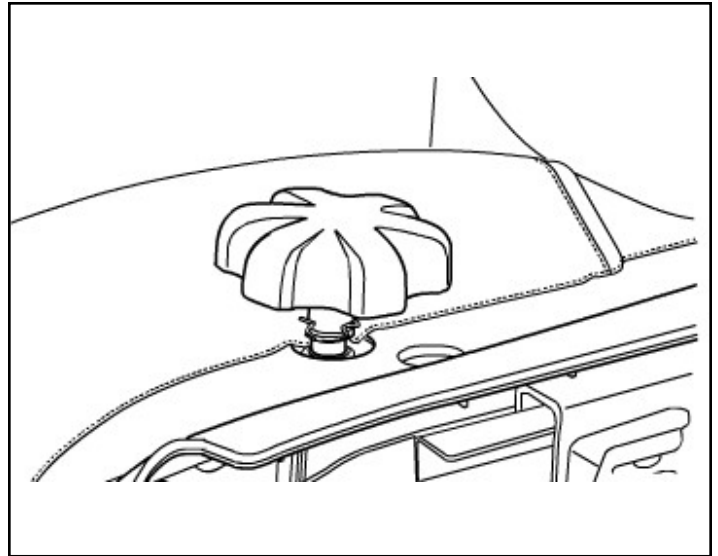

Front Seat Wiring Harness Repair Procedure:

NOTE:

If the seat side airbag harness is damaged, the seat side airbag is not deployed and the driver's seat vertical adjuster is broken, replace the seat height adjuster assembly prior to repairing the SAB wiring harness as outlined in this bulletin.

NOTE:

The following procedure shows the repair being performed on driver's seat. The passenger seat repair is similar.

- 1) Place the seat on a clean surface to perform the wiring harness repair.
- 2) Measure and record the length of the harness between where the harness exits the seatback (1) and the end of the connector (2).
- 3) Release the seatback covering band by separating the plastic retainer strips (1).

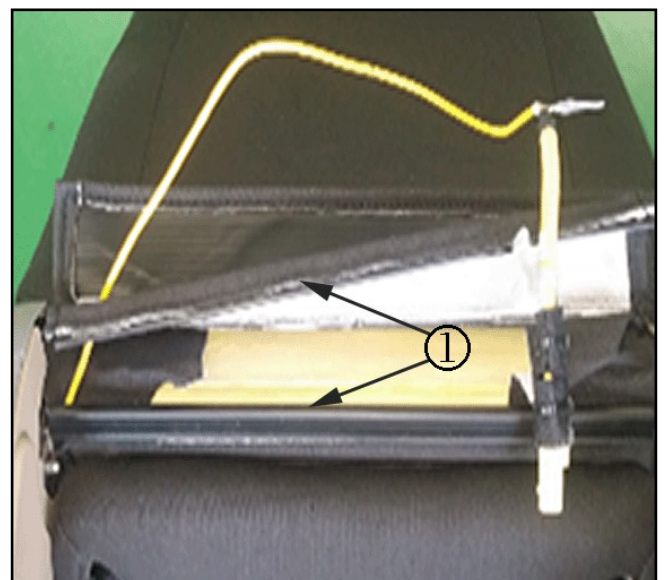
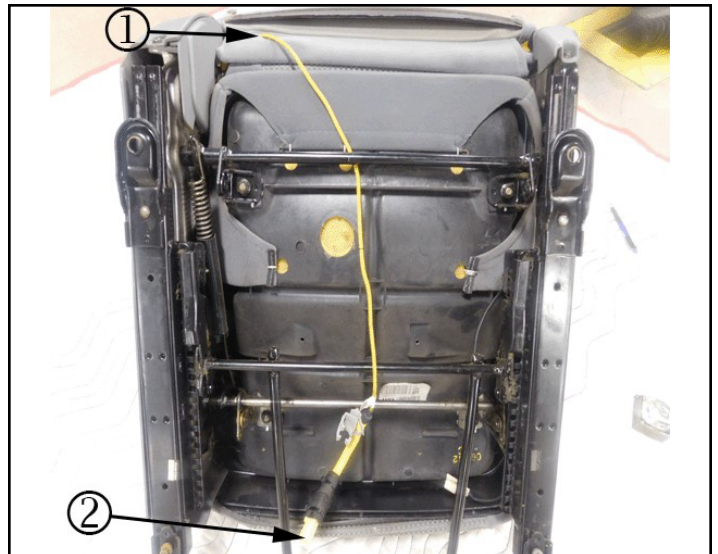

- 4) The SAB wiring harness will be cut in two locations. The first cut is where the SAB harness exits the seat-back near the recliner rod (1). If the wire harness is damaged/chafed in this area, cut the wire just above the damaged area so the remaining wire in the seat is free of any damaged insulation. The second cut will be performed in step 6. Retain the removed harness with the attached connector for step 10.



- 5) Pull the SAB wire harness out from the seatback and inspect the wire for any additional damage or chaffing. If necessary, cut out the damaged section and retain this additional damaged wire for step 7.

- 6) Lay the cut-off SAB wire harness with connector on a flat surface.

6.1 Measure and cut the wire 50mm (2 in) from the harness conduit shrink tube retainer.

6.2 Retain the cut SAB harness and connector for reattachment in step 10.

6.3 Remove and discard the gray harness retaining clip (1).

- 7) Measure the total length of the original SAB wiring harness removed in steps 4, 5 and 6.

- 8) Cut this same total length of wire from the coil of SAB harness supplied in the SAB Harness Repair Kit. This will be spliced back into the SAB harness so that the overall repaired harness length will be the same as the original harness prior to the repair.

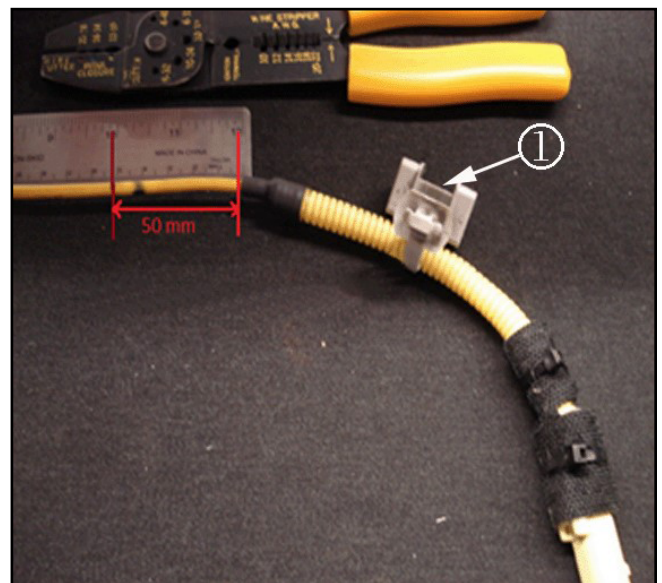

⚠ CAUTION

Be careful not to damage the insulation of the blue and brown SAB harness wires while stripping away the outer yellow insulating jacket.

- 9) Remove 50mm (2 in) of the yellow insulating jacket from both ends of the new wire cut in the previous step.
- 10) Remove 50 mm (2 in) of the yellow insulating jacket from the end of the SAB harness connector and 50mm (2 in) from the SAB wire harness still attached to the seatback.
- 11) Strip 10mm (0.4 in) of insulation from the 4 blue and 4 brown insulated wires that will be joined.
- 12) Beginning with the SAB harness wire located in the seatback, slip a 20mm (0.8 in) length of shrink tube over each wire (1) and crimp the blue and brown wires to the corresponding wires of the new harness using a splice clip from the SAB Wire Harness Repair Kit (2).
- 13) Slip a 20mm (0.8 in) length of shrink tube over each wire at the other end of the new harness and then crimp the blue and brown wires of the harness to the corresponding blue and brown wires of the SAB harness connector using two splice clips from the SAB Wire Harness Repair Kit.

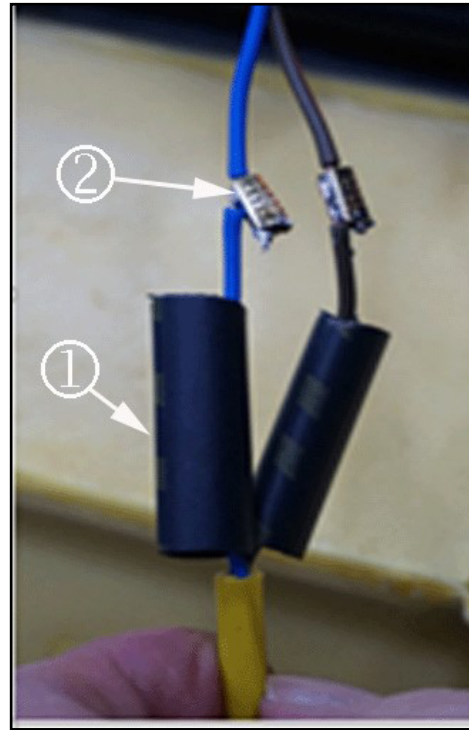

⚠ WARNING

DO NOT use soldering equipment that is battery or electric powered. These types of soldering irons can induce voltage into the circuit, which may cause inflator module deployment and/or damage to electrical components. Use only the EL-28125-5 Ultra Torch or another butane-fueled soldering iron when working on SIR circuits.

⚠ CAUTION

Keep the heat shrink tube (1) away from the splice when soldering the splice (2) to ensure that the heat shrink is not prematurely shrunk and closed down over the wire or splice area due to the heat from the soldering iron.

NOTE:

Use rosin core lead solder — the higher lead content has a lower melting point.

- 14) Solder the crimp and splice clips using the Ultra Torch, part number J-38125-5, or a similar butane-fueled soldering iron (2).
- 15) Center the heat shrink tube (1) over each of the 4 splices (2) and use the Ultra Torch, P/N J-38125-5, or a similar butane fueled soldering iron, to shrink and seal the heat shrink tube securely over the splice crimp and insulated wires.

NOTICE

ONLY use a butane-fueled soldering iron.

Using an AC-powered or DC-powered soldering iron can cause the airbag to deploy.

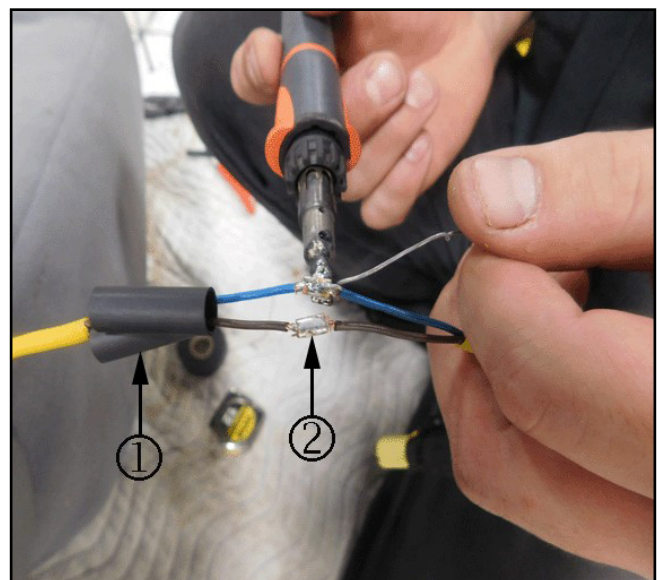

- 16) Wrap the repaired section of the SAB harness with the fleece electrical tape supplied in the SAB Wire Harness Repair Kit.



- 17) Make two cuts in the seatback, one in the seatback foam and the second in the fabric close-out panel flap. Measure 60mm (2.4 in) from the outboard edge of the foam, then cut down 50mm (2 in) from the top edge of the foam using a utility knife (1). Measure 60mm (2.4 in) from the outboard edge of the close-out cloth flap and cut down 50mm (2 in) from the top edge of the close-out cloth flap with scissors (2).

NOTE:

The driver's seat repair shown; the passenger seat repair is similar.

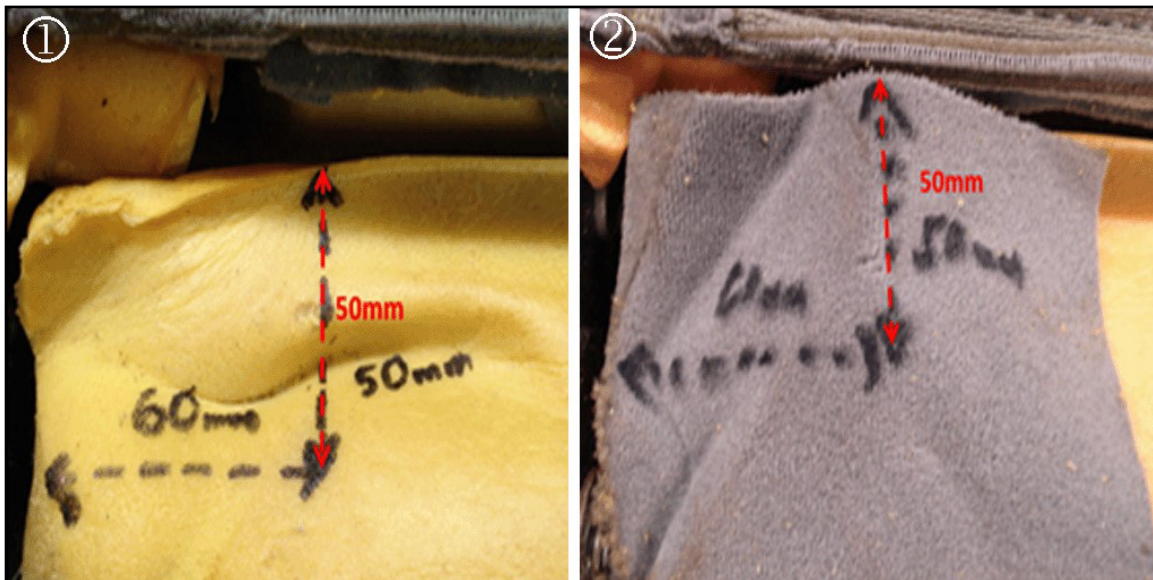

- 18) Route the SAB harness under the seatback main frame tube (1) and guide the harness through the cut section of the seatback foam (2).

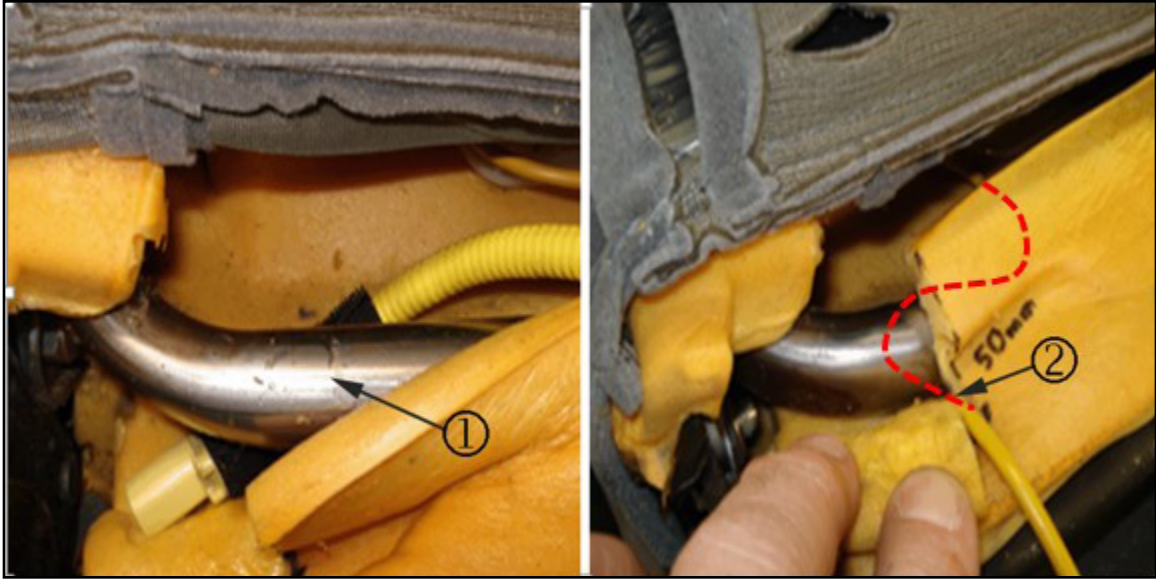

- 19) Place the seatback cloth close-out panel flap over the cut foam and SAB wiring harness (1). Then route the harness through the hole (2) in the seatback covering band and secure the seatback covering band.

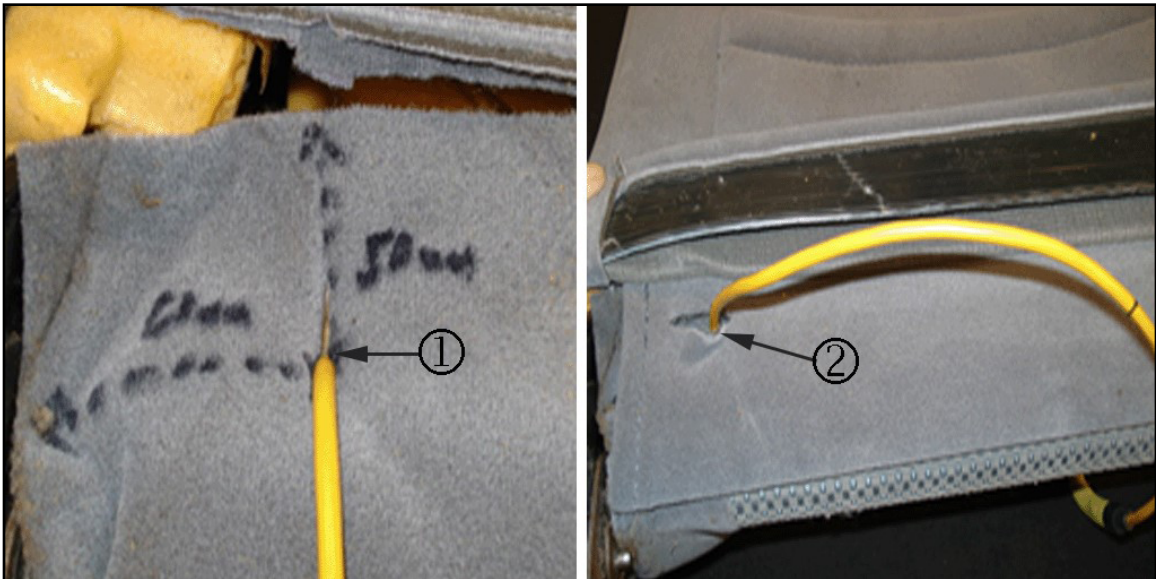

SAB Harness Routing:

NOTE:

Vehicles built prior to April 7, 2006 are equipped with a white plastic conduit retainer (1) on the SAB harness at the floor harness connector.

Vehicles built after April 7, 2006 have a Velcro strap secured to the SAB connector (2). This difference will affect the final SAB harness routing procedure.

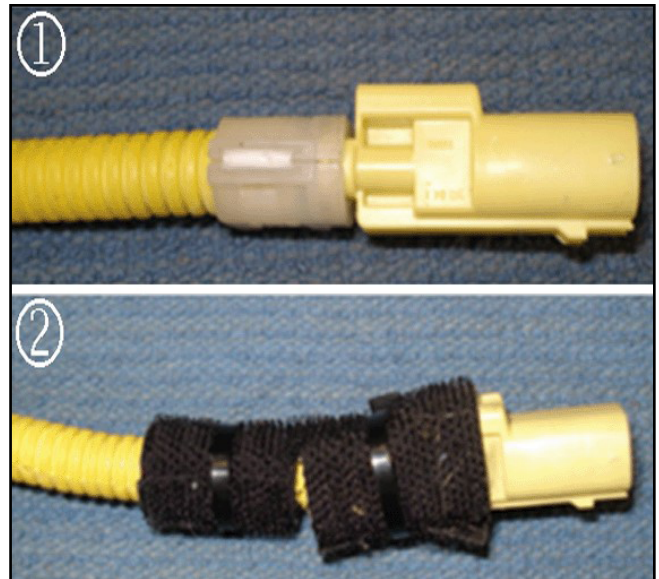

20) Verify which SAB harness design the vehicle was built with:

Vehicles built before April 7, 2006 without the Velcro Strap:

The SAB wire harness should be routed/attached to the underside (as viewed with the seat installed in the vehicle) of the seat vertical height adjuster cross bar. Loosely secure the SAB wiring harness to the rear cross bar using one wire tie as shown below. The end of the SAB connector should extend approximately 155 mm (6.1 in) beyond the front seat height adjustment cross bar as shown in lower left photo.

Vehicles built after April 7, 2006 with the Velcro Strap:

The SAB wire harness should be routed/attached to the underside of the seat vertical height adjuster cross bars (as viewed with the seat installed in the vehicle) with two wire ties. Loosely secure the SAB wiring harness to both the front and rear cross bars using two wire ties as shown. The end of the SAB connector should extend approximately 263 mm (10.3 in) beyond the front seat height adjustment cross bar as shown in upper right photo. If the end of the SAB connector cannot extend 263mm (10.3 in), secure the SAB wiring harness to the rear cross bar using only one wire tie as shown in lower left photo.

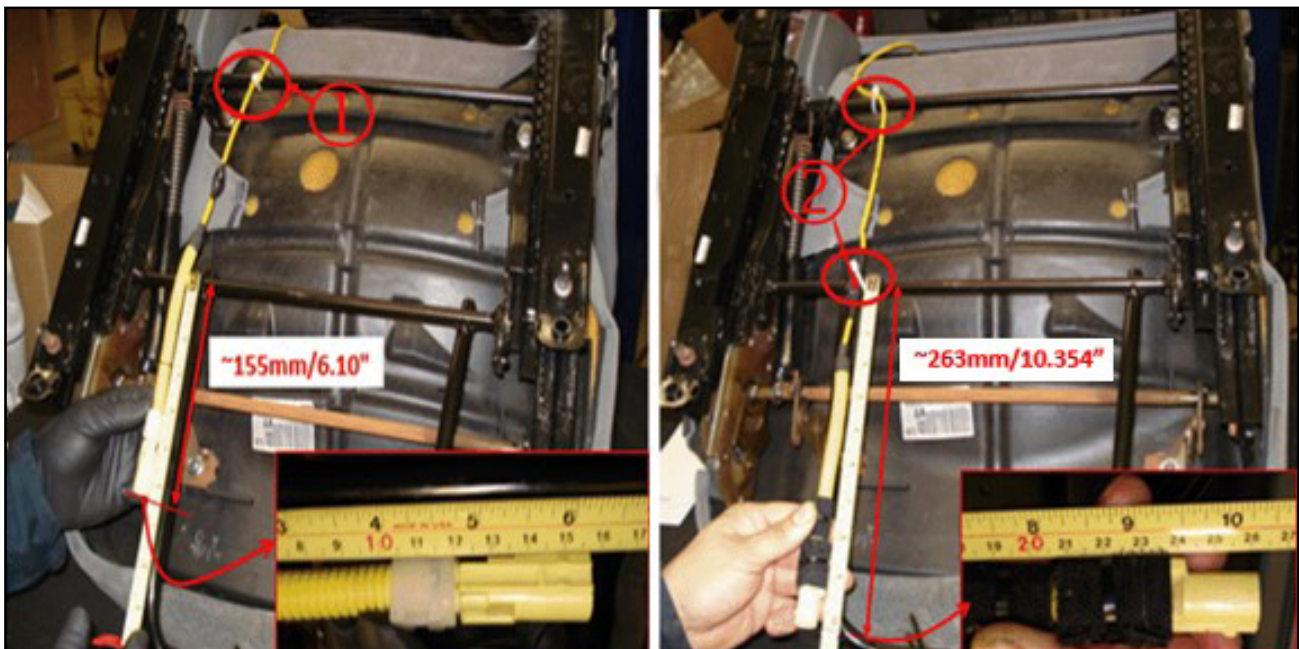

- 21) Install the seat in the vehicle and reconnect the SAB harness to the vehicle floor harness. Refer to **Front Bucket Seat Removal and Installation** in Suzuki Pit Stop Plus.
- 22) As noted earlier, the driver's seat requires proper positioning to check for pinching or binding of the SAB harness. If the driver's seat was not properly positioned at the start of this procedure, position the driver's seat with the following procedure:

22.1 Raise the front of the seat cushion all the way up (driver side only).

22.2 Lower the rear of the seat cushion all the way down (driver side only).

22.3 Tilt the seatback all the way forward (driver's and passenger's seat).

22.4 Move the seat all the way forward and visually inspect the SAB harness under the seat for pinching, binding or straining. There should be free movement of the SAB harness under the seat.

22.5 Move the seat assembly all the way rearward and visually inspect the SAB harness under the seat for pinching, binding or straining. There should be free movement of the SAB harness under the seat.

- 23) Tighten the tie strap(s) to the seat cross bars and secure the SAB harness connector to the carpet using the Velcro strip, if equipped. Refer to the image to the right.

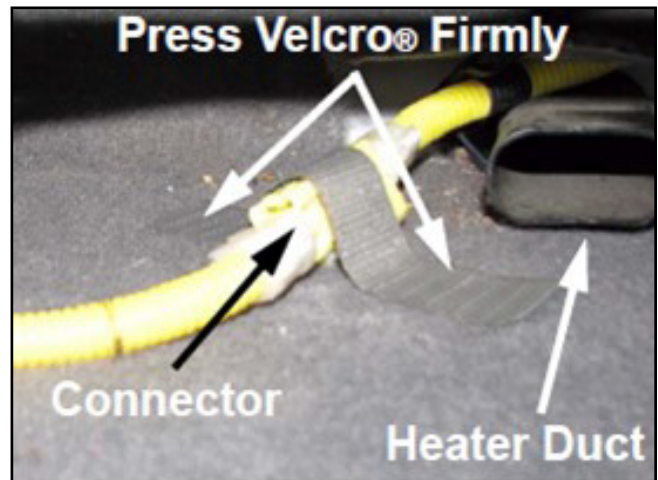

Seat Fabric Color Identification

If the driver's or passenger's seat(s) requires replacement from an unintended deployment of the SAB and the original cloth seating appearance is different than the seat material shown to the right, all the vehicle seats will require replacement.

All the parts on the following page with an asterisk (*) must be ordered to replace all the seats in the vehicle. Any cloth or leather seat color and pattern other than what is shown to the right is no longer available.

NOTE:

The new front seat assemblies replaced will contain the new SAB harness routing. No additional re-work will be required.



Parts Information:

All parts listed below except the SAB Wire Harness Repair Kit, P/N 85355-85Z00, will be on restricted ordering. Suzuki Connect will display “BO” under Parts availability for these items.

Contact Parts Coordination at parts@suz.com or (714) 854-2165 to order the parts needed, or place your order through Suzuki Connect and contact Parts Coordination to have the parts released for shipment.

No.	Part Number	Part Description	Quantity	Note
1	Call Tech-Line for Information	Sensing & Diagnostic Module	As Required	Only required if DTCs will not clear.
2	85355-85Z00	SAB Wire Harness Repair Kit	1 Per Front Seat	Wire Harness, Wire Splices, Shrink Tube and Tape
3	85101-85ZH0	Passenger Seatback Assembly	1	Split Gray Cloth
4	85102-85Z90	Driver Seatback Assembly	1	Split Gray Cloth
5	86620-85Z00	Driver Seat Adjuster Assembly	1	Driver’s Side
6	*85001-85ZQ0	Passenger Seat Assembly	1	Split Gray Cloth
7	*85002-85ZB1	Driver Seat Assembly	1	Split Gray Cloth
8	*86401-85ZC0	Rear Seat Headrest, Center	1	Split Gray Cloth
9	*86401-85ZD0	Rear Seat Headrest, Sides	2	Split Gray Cloth
10	*87101-85Z50	Rear Cushion Assembly	1	Split Gray Cloth
11	*87302-85ZB0	Rear RH Seatback Assembly	1	Split Gray Cloth
12	*87302-85Z40	Rear LH Seatback Assembly	1	Split Gray Cloth

** Parts with an asterisk are required when replacing all the seat assemblies in the vehicle.*

Warranty Information:

Submit a warranty claim for each repair immediately upon completion. For this repair, you are required to file a Long Campaign Form warranty claim.

SIDE AIRBAG HARNESS SUZUKI CONNECT LONG FORM INSTRUCTIONS	
CLAIM INFORMATION:	
CLAIM NUMBER:	XXXXX.X (Dealer enters number)
ENTRY TYPE:	VIN, Model/Frame or Control (Dealer chooses)
REPAIR DATE:	Enter date of repair
MILEAGE:	Enter mileage at repair date
CAMPAIGN NUMBER:	ZH
VARIATION CODE:	JK (Only use the JK Variation Code)
LABOR OPERATION:	SN9999
LABOR TIME	0.3 HR – SDM DTC Review and Driver’s Seat Height Adjuster Inspection (includes Driver’s SAB Harness Re-routing)
	0.3 HR – Either Front Seat Assembly Replacement
	0.6 HR – Either Front Seatback Replacement
	1.2 HR – Replace All Seat Assemblies in Vehicle
	0.9 HR – Either Front Seat SAB Harness Repair with Re-routing
	0.2 HR – Additional Time, Seat Height Adjuster/Seat Track Replacement
	0.4 HR – SDM Replacement (if necessary)
PARTS INFORMATION:	
REPLACEMENT PART	List parts replaced
DESCRIPTION OF DEFECT:	DTC B1380 and/or B1384 and/or B1379
DESCRIPTION OF REPAIR:	Describe the operations performed



SUZUKI MOTOR OF AMERICA, INC.

DAMAGE TO FRONT SIDE AIRBAG HARNESS Special Warranty Extension

This Notice Applies to Your Suzuki Vehicle Identification Number (VIN)
XXXXXXXXXXXXXXXXXXXX

August 24, 2016

Dear Suzuki Vehicle Owner:

What is the problem?

This letter is intended to make you aware that on some model-year 2005 – 2008 Suzuki Forenza and Suzuki Reno vehicles the front seat side airbag harness may be damaged from the front seat recliner hinge or the seat height adjuster. The damaged harness may cause the airbag readiness light to illuminate in the instrument panel and set a supplemental restraint system (SRS) diagnostic trouble code (DTC) B1380, B1384 or B1379. If a damaged seat side airbag harness is not repaired, the seat side airbag may deploy within three seconds of turning on the ignition, or the seat side airbag may not deploy in an accident. Suzuki Motor of America, Inc. (SMAI) will provide additional warranty coverage for the above condition for a period of 12 years or 150,000 miles/240,000 kilometers, whichever occurs first, from the date the vehicle was originally placed in service, regardless of ownership.

Please do NOT take your vehicle to your Suzuki Service Provider as a result of this letter, unless you believe that your vehicle has the condition described above.

What is Suzuki Motor of America, Inc., going to do to solve this concern?

If you believe your vehicle has the condition described above, your Suzuki Service Provider will perform the necessary seat side airbag harness repair. If your vehicle experienced an unintended seat side airbag deployment as a result of the condition described above, the seat assembly will be repaired or replaced as necessary. This procedure will take less than two hours to complete. Repair parts are available now. There will be no charge to you for any warranty extension service-related parts or labor used to repair your vehicle. Please be aware that diagnosis and repair for conditions other than the condition described above are not included in this special warranty extension.

What you should do:

If you believe that your vehicle has the condition described above, repairs and adjustments qualifying under this special coverage must be performed by a Suzuki Service Provider. You may want to contact your local Suzuki Service Provider to schedule an appointment convenient to your schedule to verify if the above condition is present in your vehicle. This will also allow your Suzuki Service Provider to order parts if they are not already in stock. While calling your Suzuki Service Provider, ask for information about other important recalls that may apply to your vehicle. You can also view important information about your Suzuki Automobile at www.suzukiauto.com under the **Campaigns** tab at the top. Keep this letter with your other important glove box literature for future reference.

Customer reimbursement for remedies prior to warranty extension notification:

If your vehicle is included in this warranty extension coverage and you have paid for repairs to address a failure of the seat side airbag for the conditions described in this notification, you may be eligible for full or partial reimbursement. Please note the following conditions for reimbursement:

- Only repairs made to address the condition that led to this warranty extension are reimbursable. Additional expenses such as towing, car rental, accommodations, damage repairs, etc., will not be reimbursed. Reimbursement will not be provided for routine scheduled maintenance.
- Reimbursement may be limited to the suggested list price for parts, the Suzuki published flat rate time allowance for the repair, and the labor rate that an authorized Suzuki Service Provider in the same area would charge for the same repair.
- Reimbursement claims may also be excluded when adequate documentation is not submitted by the claimant. This includes a copy of repair order, and proof of payment for the repair.

To apply for reimbursement:

- 1) Go to www.suzukiauto.com.
- 2) Select **Campaigns** tab at the top of the home page.
- 3) Select **Side Airbag Reimbursement**.

Who to contact if you experience problems:

Your Suzuki Service Provider can provide you the fastest response to your questions or concerns about the Seat Side Airbag Warranty Extension. If you have any difficulty with this warranty extension, you may contact the Suzuki Motor of America, Inc., Customer Service Department, for assistance at (800) 934-0934, during the hours of 7:00 AM to 4:30 PM Pacific Time. Please have your vehicle identification number (VIN) ready when calling.

If you need to locate your nearest Suzuki Service Provider, please visit www.suzukiauto.com and click on the **SERVICE PROVIDERS** tab, which is located in the upper-right corner of our website.

We apologize for any inconvenience this warranty extension causes you. We hope you understand that your safety and satisfaction with Suzuki Automobiles are important priorities for us.

Sincerely,

Suzuki Motor of America, Inc.