

September 14, 2016

03124 Version 4

## Warranty Extension: 2008–10 Accord SRS Unit

Supersedes 16-007, dated April 9, 2016 to revise the information highlighted in **yellow**

### AFFECTED VEHICLES

Year	Model	Trim	VIN Range
2008–10	Accord	4-Door	Check the iN VIN status for eligibility

### REVISION SUMMARY

Descriptions were added to the DTCs listed under **BACKGROUND**.

### BACKGROUND

American Honda is extending the warranty on the SRS unit to 15 years from the original date of purchase with no mileage limit for the SRS indicator being on with one of the following DTCs stored:

- 51-XX (internal failure of the SRS unit)
- 53-XX (internal failure of the SRS unit)
- U0151 (gauge control module lost communication with SRS unit [SRS message])
- The HDS does not communicate with the SRS unit

This warranty extension will not apply to any vehicle that has ever been declared a total loss or sold for salvage by a financial institution or insurer, or has a branded or similar title under any state's law.

### CUSTOMER NOTIFICATION

Owners of affected vehicles will be sent a notification of this campaign.

Do an iN VIN status inquiry to make sure the vehicle is shown as eligible.

### CORRECTIVE ACTION

If the SRS indicator is on, do the inspection, and if the DTC is listed above or the HDS does not communicate with the SRS unit, replace the SRS unit.

### PARTS INFORMATION

Part Name	Part Number Ordered	You may receive any of the following	Quantity
SRS Unit	77960-TA0-A02	77960-TA0-A02 77960-TA0-L02	1
Torx Bolts	90137-S84-A01	N/A	3

**CUSTOMER INFORMATION:** The information in this bulletin is intended for use only by skilled technicians who have the proper tools, equipment, and training to correctly and safely maintain your vehicle. These procedures should not be attempted by "do-it-yourselfers," and you should not assume this bulletin applies to your vehicle, or that your vehicle has the condition described. To determine whether this information applies, contact an authorized Honda automobile dealer.

## WARRANTY CLAIM INFORMATION

### For inspection with no SRS unit replacement:

Use this warranty claim information if the SRS indicator was on but the SRS unit was not replaced. To avoid non-payment the DTC must be entered in the DTC field.

NOTE: Only inspect the vehicle when the SRS indicator is ON. AHM will pay for one inspection with the SRS indicator on regardless of the DTC. **Any subsequent inspections are customer pay unless the SRS unit does not communicate with the HDS or DTCs 51-XX, 53-XX, or U0151 are stored.**

Operation Number	Description	Replacement Part Number	Flat Rate Time	Defect Code	Symptom Code	Template ID	Failed Part Number
7525B1	Inspect the vehicle.	No parts replaced.	0.3 hr	6R200	JX100	16-007A	77960-TA0-A01

### For inspection where the SRS unit is replaced:

To avoid non-payment of warranty claims, the SRS unit ID (serial number) must be entered in the serial number field of the warranty claim.

Use this warranty claim information if the SRS unit was replaced because the HDS did not communicate with the SRS unit or DTC(s) 51-XX, 53-XX, or U0151 were stored.

Operation Number	Description	Replacement Part Number	Flat Rate Time	Defect Code	Symptom Code	Template ID	Failed Part Number
7525B1	Inspect the vehicle.	SRS unit was replaced.	0.3 hr	6R200	JX000	16-007B	77960-TA0-A01
7511C1	Replace the SRS control unit – add if replacing.	77960-TA0-A02	0.8 hr				
7525B1	Inspect the vehicle.	SRS unit was replaced.	0.3 hr	6R200	JX000	16-007C	77960-TA0-A01
7511C1	Replace the SRS control unit – add if replacing.	77960-TA0-L02	0.8 hr				

## INSPECTION PROCEDURE

1. Turn the ignition to ON and check if the SRS indicator comes on for about 6 seconds, then turns off.
  - If the indicator comes on, then goes off after about 6 seconds, the vehicle is OK.
  - If the indicator does not come on, or if it stays on, go to step 2.
2. Check for DTCs.
  - If any of the following DTCs appears or the HDS does not communicate with the SRS unit, go to REPAIR PROCEDURE.
    - 51-XX
    - 53-XX
    - U0151
  - For all other SRS DTCs, these repairs are not covered under this warranty extension.
    - Contact the customer and inform them that the problem with the SRS is not covered by this warranty extension and that it is a customer pay repair.
    - If the customer declines the customer pay repairs, make sure you write down the description of the problem and the DTCs on the RO. Also indicate on the RO that the SRS is not operating properly and may pose a risk to the occupants in the event of a collision, either because the airbags may not deploy, or the airbags may deploy in a manner that does not account for all factors involved in the collision.

## REPAIR PROCEDURE

1. Do the battery disconnection procedure, then wait at least 3 minutes before starting work.

NOTE: Make sure you have the anti-theft code for the audio system or the navigation unit and record the customer's audio unit presets.

2. Remove the driver's and front passenger's dashboard center lower cover.
  - Detach the clip by carefully pulling out the front edge of the console, then up to release the hooks from the dashboard.
  - Carefully pull out the front area of the console to allow room to access and remove clip No. 1.
  - Remove the dashboard center lower cover by releasing clip No. 2, then lift up to release the hook from the heater duct.

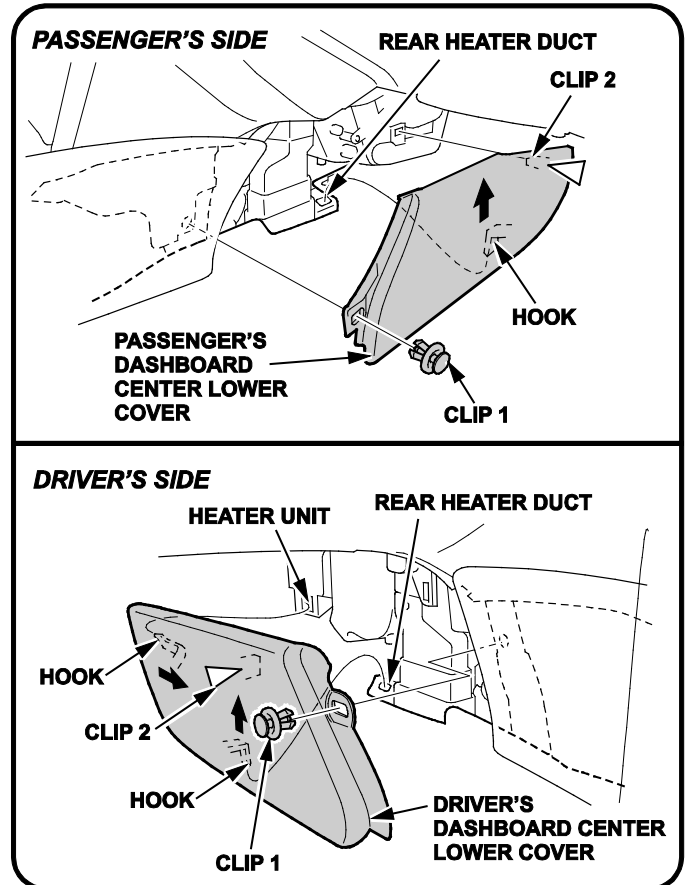
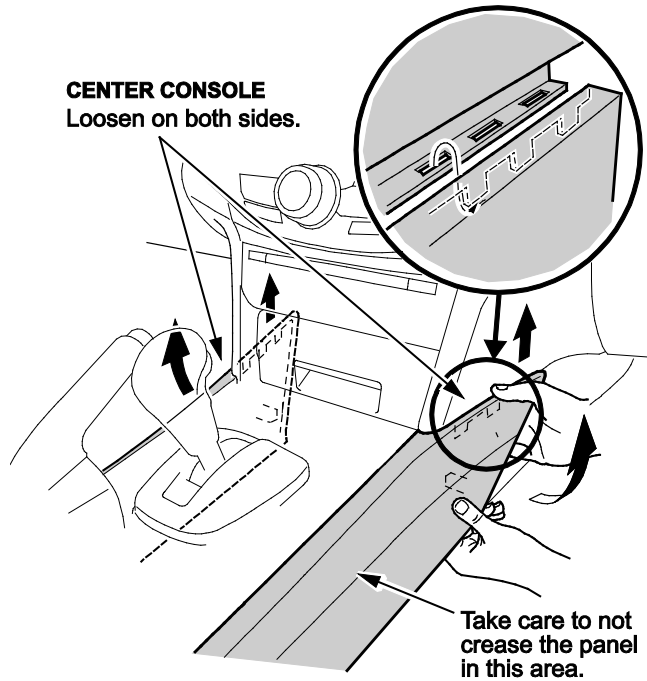

3. Remove the Torx bolt.

### DRIVER'S SIDE

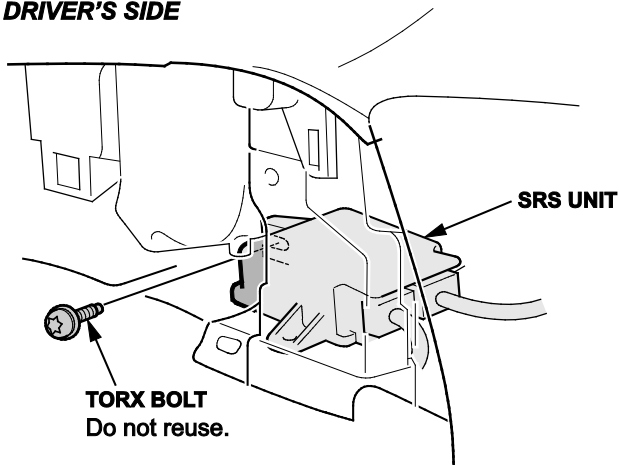

4. Remove the heater duct clip, then remove the heater duct.

**DRIVER'S SIDE**

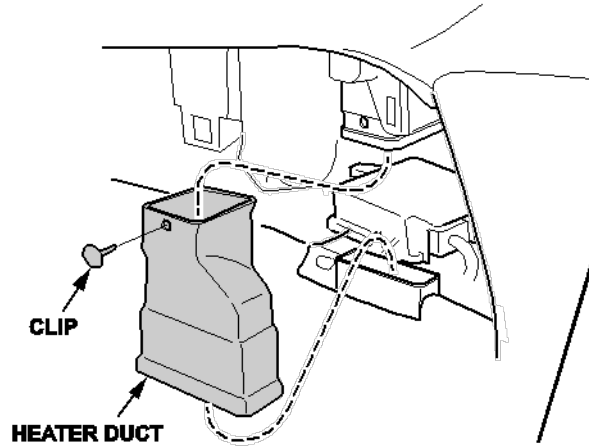

**PASSENGER'S SIDE**

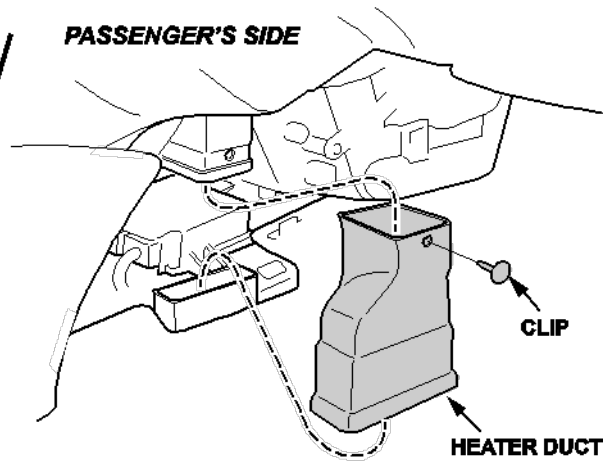

5. Disconnect the SRS unit connectors from the SRS unit by releasing the lever locks, then pull on the lever to disconnect the connectors.

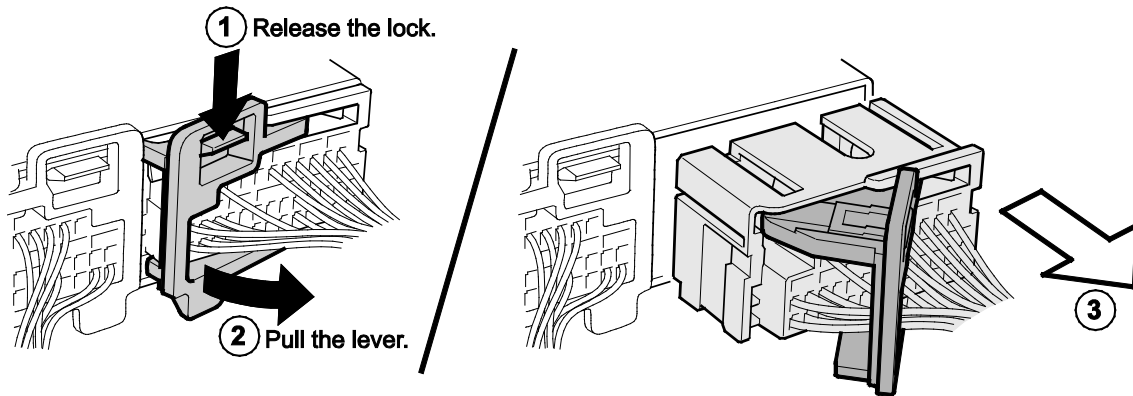

6. Remove the Torx bolts and remove the SRS unit.

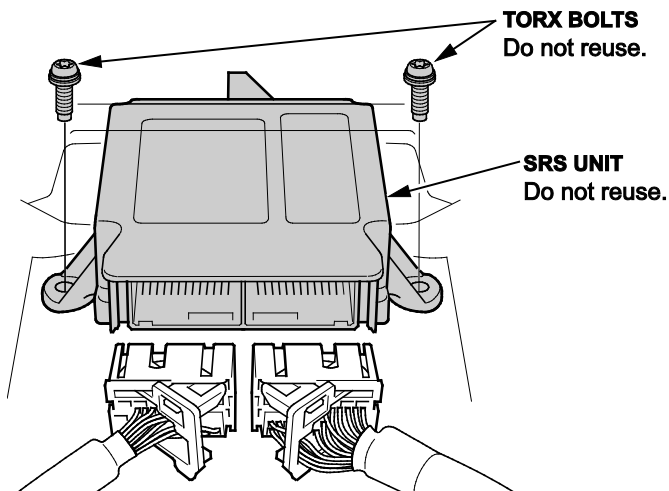

7. Write down the new SRS unit ID (serial number) on the RO, then install the new SRS unit using the new Torx bolts.

NOTE: Make sure the SRS unit is sitting squarely against its bracket before torquing the Torx bolts.

REVISED IMAGE

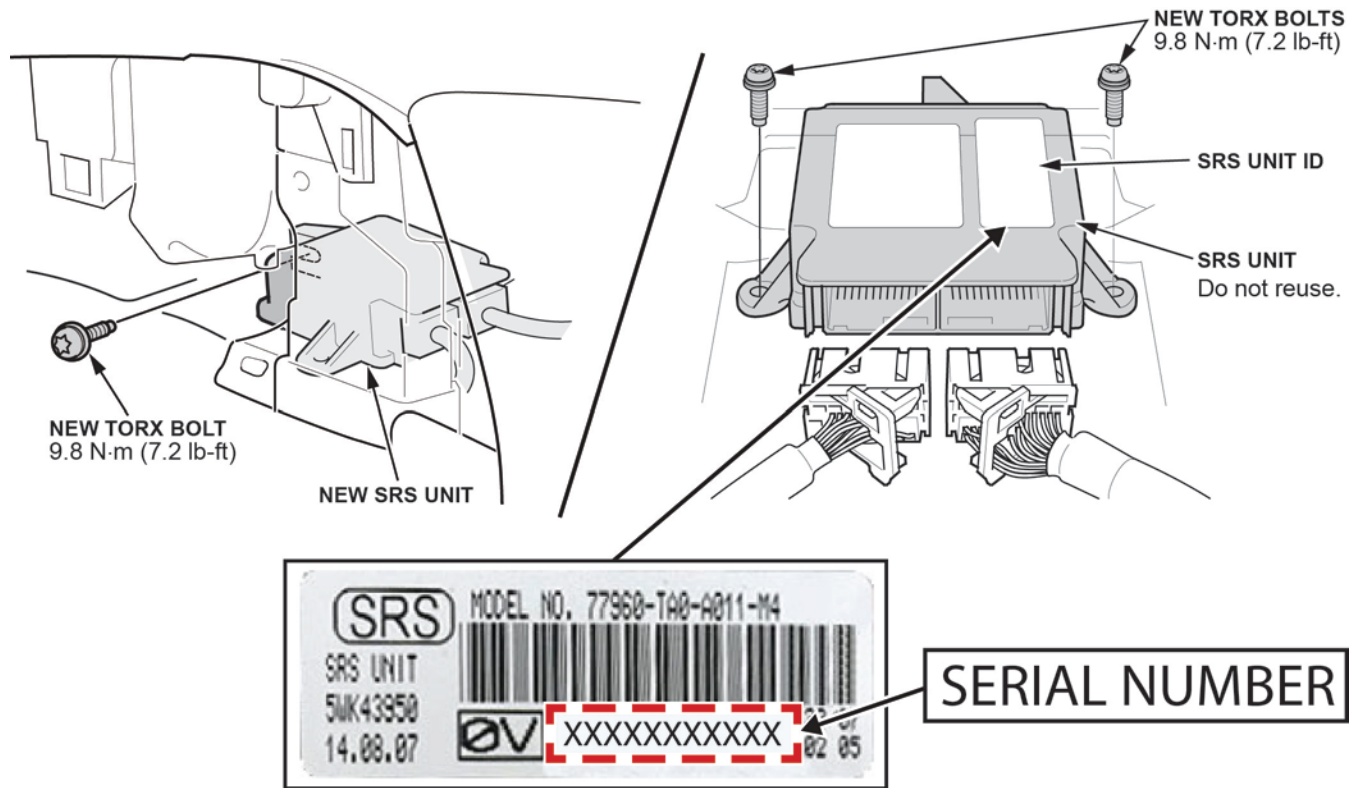

8. Connect the SRS connectors to the SRS unit by pushing the connector in and the lever moves to the locked position.

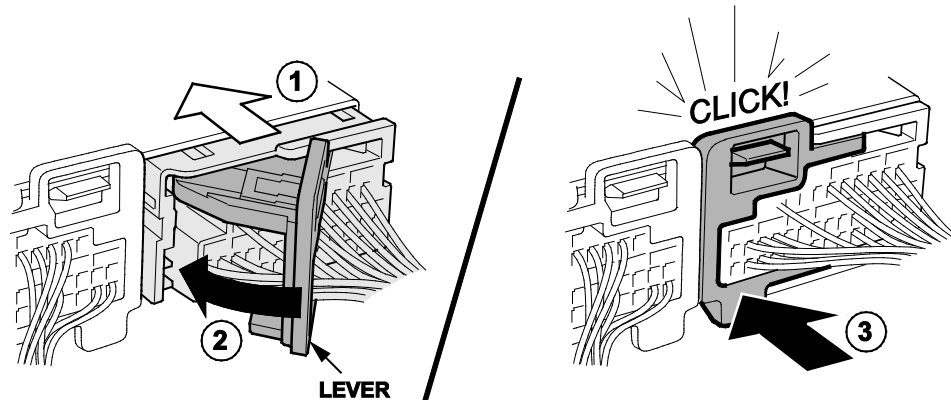

9. Do the battery terminal reconnection procedure.

10. Ready the vehicle for OPDS initialization by doing the following:

- Move the front passenger's seat back to the most upright position.
- Slide the front passenger's seat all the way back.
- Make sure there is nothing in the front passenger's seat back pocket.
- Make sure there is nothing under the front passenger's seat.
- Make sure the vehicle is parked out of direct sunlight.
- Make sure the vehicles temperature has stabilized to the shop temperature (do not initialize the vehicle in extreme cold or hot temperatures).

11. To complete SRS unit initialization, **turn the ignition to ON for 1 full minute, turn the ignition to OFF for another minute, then repeat two more times, making sure to wait 1 full minute between the ignition ON or OFF.** After cycling the ignition 3 times, turn the ignition to ON and if the SRS indicator comes on for about 6 seconds then goes off, the SRS unit initialization is complete.
12. Enter the anti-theft codes for the audio and navigation system (if applicable), then enter the customer's audio unit presets.
13. *Vehicles without navigation:* Set the clock.
14. Reinstall all removed parts in the reverse order of disassembly.
15. Give your warranty clerk the RO that includes the stored DTC(s) and the replacement SRS unit serial number.

END