

Subject: TPMS WARNING LIGHT ON	Bulletin No: 02-012/16
	Last Issued: 07/29/2016

APPLICABLE MODEL(S)/VINS

2016 CX-3 equipped with AWD

DESCRIPTION

Some vehicles may experience a Tire Pressure Monitoring System (TPMS) warning light on when driving on a smooth road surface even if the TPMS system has been properly initialized at the specified tire air pressure.

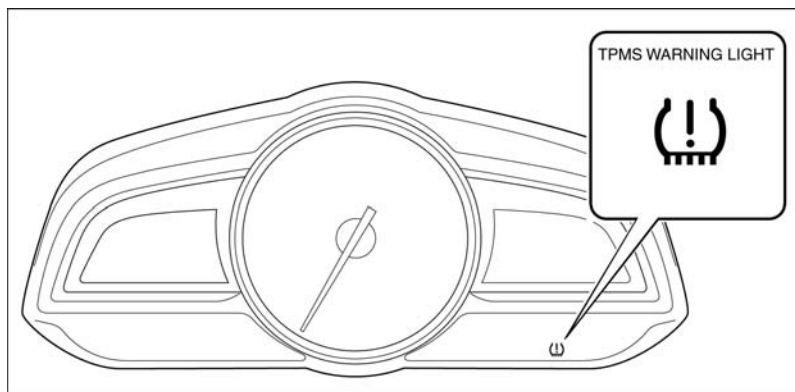

The TPMS system may have been improperly initialized when the initialization was performed on certain types of rough road surfaces. Then, when driven on smooth road surfaces, the TPMS system may detect improper tire air pressure. The DSC HU/CM control logic has been changed for this concern.

Customers having this concern should have their vehicle repaired using the following repair procedure.

REPAIR PROCEDURE

1. Verify customer concern.
2. Are all four tire pressures at specification?
Tire Pressure Specification: Front; 36 psi, Rear; 33 psi
 - a. Yes - Go to step 3.
 - b. No - This service bulletin does not apply.
3. Replace the DSC HU/CM. Refer to MS3 Workshop Manual online DSC HU/CM REMOVAL/INSTALLATION.
NOTE: Rear brake pad replacement is necessary for proper brake system air bleeding.
4. With Mazda Modular Diagnostic System (M-MDS), perform the TPMS initialization. Refer to MS3 Workshop Manual online TIRE PRESSURE MONITORING SYSTEM INITIALIZATION PROCEDURE. This will initialize TPMS and disable the mis-use prevention logic at the same time.
5. Verify repair.

Bulletin No: 02-012/16 © 2016 Mazda Motor of America, Inc.	Last Issued: 07/29/2016
--	--------------------------------

PART(S) INFORMATION

Part Number	Description	Qty.	Notes
DDY3-43-7A0A	UNIT,HYDRAULIC-ABS	1	Without SBS
DBY5-43-7A0A	UNIT,HYDRAULIC-ABS	1	With SBS
D1Y1-26-49Z	REAR BRAKE PAD	1	Brake bleeding requires rear brake piston compression. The double-sided adhesive tape for the rear brake pads and shims cannot be reused.

WARRANTY INFORMATION

NOTE:

- This warranty information applies only to verified customer complaints on vehicles eligible for warranty repair.
- This repair will be covered under Mazda's New Vehicle Limited Warranty term.
- Additional diagnostic time cannot be claimed for this repair.

Warranty Type	A
Symptom Code	64
Damage Code	9W
Part Number Main Cause	DDY3-43-7A0A or DBY5-43-7A0A
Quantity	1
Operation Number / Labor Hours:	XXM4YXRX / 1.8 Hrs.