

<b>Technical Service Bulletin Number</b>
--

TSB140008
-----------



## Technical Service Bulletin

### Subject

---

New EGR Coolers for ISC/ISL Diesel Engines and ISL G Gas Engines

### Warranty Statement

---

The information in this document has no effect on present warranty coverage or repair practices, nor does it authorize TRP or Campaign actions.

### Contents

---

This document introduces a new vertical plate exhaust gas recirculation (EGR) cooler.

#### Product Affected:

- ISC8.3 CM2150
- ISC8.3 CM2250
- ISL CM2150
- ISL9 CM2250
- ISL9 CM2350 L101
- ISL G CM2180

To replace the EGR cooler, see Procedure 011-019 in Section 11 of the appropriate service manual.

For detailed installation instructions on how to upfit an engine with a horizontal plate EGR cooler to a vertical plate EGR cooler, refer to Installation Instruction, Replacement of a Horizontal Plate Exhaust Gas Recirculation (EGR) Cooler With a Vertical Plate EGR Cooler, Bulletin 4908175.

## Gas Engines:

See the table below for details. The present EGR cooler is being superseded. When replacing EGR cooler, Part Number 4990739, the customer **must** order one of the installation kits listed below. The kit contains the coolant vent line for installation. Reference Procedure 008-017 in Section 8 in the appropriate service manual.

**NOTE: Peterbilt™ 320 Chassis installations may need to order a new original equipment manufacturer (OEM) air intake pipe, D66-6894 PIPE-AIR INTAKE, in addition to the kit below.**

ISL G Engines			
Mounting Option	Part Number Failed	Replace With	Installation Kit Part Number
Square Cooler with High Mount Turbocharger	4990739	437631200RX	4352347
Square Cooler with Low Mount Turbocharger	4990739	437631200RX	4352348
Circular Cooler	5318560 or 5347234	437631200RX	Not Applicable

## Diesel Engines:

The new vertical plate EGR cooler is a robust design and is a required upfit to the present horizontal plate EGR cooler design.

This document consists of the instructions to order parts/kit and upfit an engine equipped with a horizontal plate EGR cooler to a vertical plate EGR cooler.

Determine the type of EGR cooler (horizontal plate or vertical plate) presently on the engine, using the illustrations and description below:

©Cummins Inc

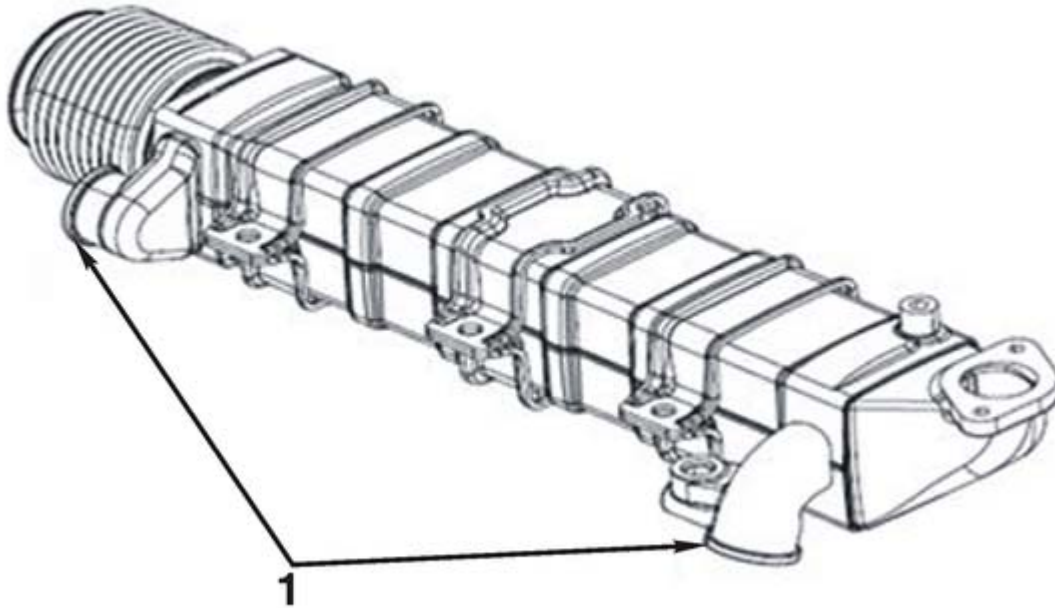

11900293

Figure 1, Horizontal Plate EGR Cooler

©Cummins Inc

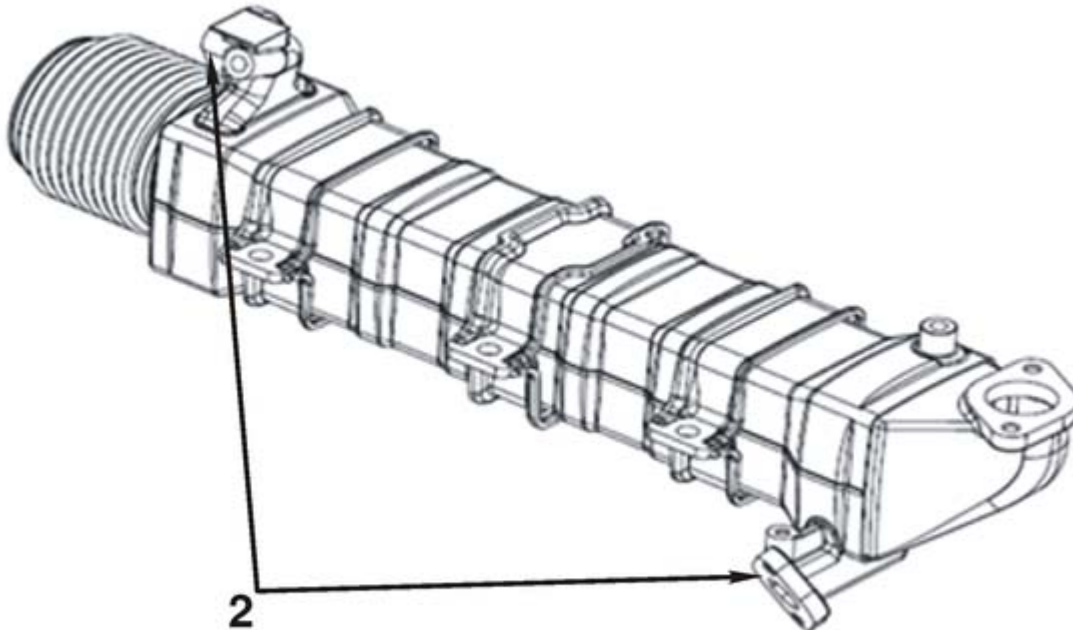

11900294

Figure 2, Vertical Plate EGR Cooler

1. The horizontal plate EGR cooler (Figure 1) is equipped with a slip fit connection (without a flange) for the coolant lines.

If the existing cooler is horizontal plate, choose one of the following:

- OEM is New Flyer, follow Case A below
- OEM is Gillig ISL CM2150 or Nova ISL CM2150 left side installation **only**, follow Case B below
- All other configurations, follow Case C below

2. The vertical plate EGR cooler (Figure 2) is equipped with a flange connection for the coolant lines.

If the existing cooler is vertical plate, choose one of the following:

- OEM is New Flyer, follow case D below
- All other OEM's, follow case E below

Order upfit parts based on conditions that satisfy the repair/case.

**Case A:** The engine is equipped with a horizontal plate EGR cooler and is used in OEM New Flyer. Order the below parts.

- Order the EGR Mounting Kit, Part Number 4376527, which includes the parts listed below.

New Part Number	Quantity	Noun Name
<b>4376527</b>	-	<b>Kit EGR Mounting</b>
2880908	1	Union, Male
3104485	1	Clamp, Spring Hose
3900630	4	Screw, Hex Flange Head C
3943933	3	Screw, Hex Flange Head C
3950161	1	Screw, Hex Flange Head C
4934278	6	Washer, Sealing
4935432	1	Coupling, Plain Pipe
5297792	1	Tube, Pressure Sensing
5297796	1	Support, Exhaust Gas RCN
5297817	1	Tube, Air Transfer
5306383	1	Bracket, Exhaust RCN Cooler
5319225	1	Connector, Male
5319450	1	Tube, Exhaust Clr Water Outlet
5337913	1	Screw, Socket Set

- Order the EGR Cooler Kit, Part Number 4376528. This kit includes the parts listed below.

New Part Number	Quantity	Noun Name
<b>4376528</b>	-	<b>Kit EGR Cooler</b>
5343328	1	Cooler, Exhaust Gas RCN
3104230	1	Gasket, Exhaust Gas RCN Valve
4932615	2	Gasket, Connection
5297806	2	Seal, Diamond Ring

- Order the individual parts below.

New Part Number	Quantity	Noun Name
<b>5364526</b>	1	<b>Tube, Exhaust Clr Water Inlet</b>

5297802	1	Tube, Vent
4938641	1	Union, Male

**NOTE:** There is no vent tube between the front of the EGR cooler vent and the rear EGR cooler vent. See Installation Instructions, Bulletin 4908175, for installing a vent tube from the rear EGR cooler vent to the OEM coolant top tank.

**NOTE:** For 2007 – 2009 New Flyer™ Diesel Low Floor Buses equipped with the ISL CM2150 and 2010 New Flyer™ Diesel Low Floor Buses built before September 2010, equipped with the ISL9 CM2250, an OEM exhaust bracket may need to be modified to allow for clearance of the new EGR cooler. Please reference New Flyer™ TSIB 16-01. See link provided. <http://www.newflyer.com/index/tsib>

**Case B:** The engine is equipped with a horizontal plate EGR cooler and is used in OEM, Gillig, or Nova (left side engine installations) (ISC/ISL CM2150 **only**) , order the below parts.

- Order the EGR Mounting Kit, Part Number 4376527. This kit includes the parts listed below.

New Part Number	Quantity	Noun Name
4376527	-	Kit, EGR Mounting
2880908	1	Union, Male
3104485	1	Clamp, Spring Hose
3900630	4	Screw, Hex Flange Head C
3943933	3	Screw, Hex Flange Head C
3950161	1	Screw, Hex Flange Head C
4934278	6	Washer, Sealing
4935432	1	Coupling, Plain Pipe
5297792	1	Tube, Pressure Sensing
5297796	1	Support, Exhaust Gas RCN
5297817	1	Tube, Air Transfer
5306383	1	Bracket, Exhaust RCN Cooler
5319225	1	Connector, Male
5319450	1	Tube, Exhaust Clr Water Outlet
5337913	1	Screw, Socket Set

- Order the EGR Cooler Kit, Part Number 4352253RX. The kit includes the parts listed below.

New Part Number	Quantity	Noun Name
4352253RX	-	Kit, EGR Cooler
5297551	1	Cooler, Exh Gas RCN
3104230	1	Gasket, Exh Gas RCN Valve
4932615	2	Gasket, Connection
5297806	2	Seal, Diamond Ring

- Order the below individual parts.

New Part Number	Quantity	Noun Name
5364527	1	Tube, Vent
5297802	1	Tube, Vent
5337987	1	Tube, Exh CLR Water Inlet
5297873	1	Coupling, Plain Pipe
3957942	2	Screw, Banjo Connector
4934278	2	Washer, Sealing

**Case C:** If the engine is equipped with a horizontal plate EGR Cooler and is **not** OEM New Flyer or a Gillig ISL CM2150 or Nova ISL CM2150 (left side engine installations), use the below instruction to upfit to a vertical plate EGR cooler:

- Order vertical plate EGR cooler kit, Part Number 4352253RX. The kit consist of the parts listed below:

New Part Number	Quantity	Noun Name
4352253RX		Kit, EGR Cooler
3104230	1	Gasket, Exhaust Gas RCN Valve
4932615	2	Gasket, Connection
5297551	1	Cooler, Exhaust Gas RCN
5297806	2	Seal, Diamond Ring

- Order EGR cooler upfit kit, Part Number 4352363. The kit consist of the parts listed below:

New Part Number	Quantity	Noun Name
4352363		Kit, EGR Cooler Upfit
5297792	1	Tube, Pressure Sensing

5297796	1	Support, Exhaust Gas RCN MDL
5319450	1	Tube, Exhaust Clr Water Outlet
5334169	1	Clip, Wire Retaining
5297804	1	Union, Male (Inlet)
5319225	1	Connector, Male (Outlet)
5297802	1	Tube, Vent
3957942	2	Screw, Banjo Connector
4934278	9	Washer, Sealing
5272389	1	Screw, Banjo Connector
4934278	9	Washer, Sealing
5272389	1	Screw, Banjo Connector
4932953	2	Coupling, Plain Pipe
4932878	2	Union, Male
4943114	1	Connector, Banjo
4941313	1	Connector, Banjo
5298148	1	Coupling, Plain Hose
4938641	1	Union, Male
5298393	1	Tube, Vent
5297873	1	Coupling, Plain Pipe
3943933	3	Screw, Hex Flange Head

- Reference the following tables to order the parts specific to the engine:

#### Vent Tube:

Order the vent tube part number listed against the turbocharger option the engine is built with. To identify the turbocharger option the engine is built with, see turbocharger option (remarks section) in parts catalog on Quickserve® Online.

Turbocharger Option	Part Number	Noun Name
Low Mount Rear Out (LMRO)	None	None
Mid Mount Rear Out (MMRO) (ISC CM2150/CM2250 and ISL CM2150/CM2250)	5315014	Tube, Vent
High Mount Rear Out (HMRO) (ISC CM2150/CM2250 and ISL CM2150/CM2250)	5304041	Tube, Vent
High Mount Rear Out (HMRO)	5304041	Tube, Vent



with HE300 Turbocharger (ISL CM2350 L101)	5314840	Tube, Drain
---	---------	-------------

#### Air Transfer Tube:

Reference the following table to order the air transfer tube.

Rocker Lever Cover	Part Number	Noun Name
Transit Bus Applications	5297817	Tube, Air Transfer
Low Rocker Lever Cover (without compression brakes)	5297810	Tube, Air Transfer
Tall Rocker Lever Cover (with compression brakes)	5297814	Tube, Air Transfer

#### EGR Cooler Water Inlet Tube:

The type of EGR cooler water inlet tube is dependent on OEM, chassis type, and engine model.

OEM	Chassis/Engine	Part Number	Noun Name
Kenworth	T3	5319448	Tube, Exhaust Cooler Water Inlet
Others	N/A	5319449	Tube, Exhaust Cooler Water Inlet

#### Charge Air Cooler Pipe:

For Gillig manufactured buses the charge air cooler pipe may need to be replaced to make room for vertical tube EGR cooler venting.

- Charge air cooler fitment is dependent upon bus model year, bus length, and engine / radiator combination.
- Contact local Gillig parts representative to determine the correct charge air cooler pipe that will provide the necessary clearance for the vertical tube EGR cooler venting. The last 5 digits of the vehicle identification number (VIN) will be needed.

#### OEM Coolant Line:

For VanHool manufactured buses the OEM coolant line above the EGR cooler may need to be replaced to make room for the vertical tube EGR cooler.

- Contact local VanHool parts representative to determine the correct coolant line that will provide the necessary clearance for the vertical tube EGR cooler.

**Case D:** The engine is already equipped with a vertical plate EGR cooler and is used in OEM New Flyer

- Order the parts listed below:

New Part Number	Quantity	Noun Name
5343328	1	Cooler, Exhaust Gas RCN
3104230	2	Gasket, Exhaust Gas RCN Valve
4932615	2	Gasket, Connection
5297806	1	Seal, Diamond Ring

**Case E:** If the engine is already equipped with a vertical plate EGR cooler, and is **not** used in OEM New Flyer, order EGR Cooler Kit, Part Number 4352253RX. The kit consist of the parts listed below:

New Part Number	Quantity	Noun Name
<b>4352253RX</b>		<b>Kit, EGR Cooler</b>
3104230	1	Gasket, Exhaust Gas RCN Valve
4932615	2	Gasket, Connection
5297551	1	Cooler, Exhaust Gas RCN
5297806	2	Seal, Diamond Ring

Production Information			
Product	Engine Serial Number (ESN) First	Build Date*	Engine Plant
ISL9 CM2350 L101	73680493	01 May 2014	Rocky Mount
*Engine build date can be found on the engine dataplate.			

## Document History

Date	Details
2014-1-20	Module Created
2014-4-14	none
2014-5-20	none
2014-6-12	none
2014-7-16	none
2014-9-27	none
2014-11-20	Updated ISL G part numbers in table. Updated Nova (ISC/ISL CM2150) - T-Drive to Nova (ISC/ISL CM2150) - left side engine installations.
2015-1-30	New information about Gillig installations. Reformatted for readability.
2015-3-5	Corrected broken link.
2015-4-9	Reformatted instructions for Gillig installations.
2015-10-13	Added New Flyer, Gillig, or Nova options and OEM coolant line section.

2015-11-20	Updated Case A, B, C, and D. Added Case E.
2016-2-8	Added engine serial number (ESN) first information.
2016-4-11	Reformatted.
2016-7-13	Added reference to New Flyer™ TSIB 16-01.

---

**Last Modified: 14-Jul-2016**

---

Copyright © 2000-2010 Cummins Inc. All rights reserved.