

August 18, 2016

04086 Version 2

## Steering Wheel Noise When Driving

Supersedes 16-025, dated May 27, 2016, to revise the information highlighted in **yellow**.

### AFFECTED VEHICLES

Year	Model	Trim	VIN range
2016–17	RDX	2WD	5J8TB3...HL000001 to 5J8TB3...HL003353
2016–17	RDX	AWD	5J8TB4...HL000001 to 5J8TB4...HL005430
2016–17	ILX	ALL	19UDE2...HA000001 to 19UDE2...HA001454

### REVISION SUMMARY

- Under AFFECTED VEHICLES, VIN ranges, and another model were added.
- Under DIAGNOSIS, the procedure was changed.
- Under REPAIR PROCEDURE, the note in step 9 was changed.

### SYMPTOM

There is a creaking, rattling, buzzing, clicking, or rubbing noise coming from the driver's airbag area of the steering wheel when turning or driving.

### POSSIBLE CAUSE

The driver's airbag rib, located below the surface of the cover, contacts the leather wrap on the steering wheel spokes at the 3 and 9 o'clock positions.

### CORRECTIVE ACTION

Trim the leather wrap on the steering wheel in the affected areas.

### PARTS INFORMATION

Part Name	Part Number	Quantity
Hex Bolt (6 mm x 23 mm)	90134-S6A-A80	2

### WARRANTY CLAIM INFORMATION

The normal warranty applies.

Operation Number	Description	Flat Rate Time	Defect Code	Symptom Code	Template ID	Failed Part Number
510135	Trim leather from steering wheel.	0.5 hr	06201	04201	16-025N	78501-TX6-A81ZA

Skill Level: Repair Technician

**CLIENT INFORMATION:** The information in this bulletin is intended for use only by skilled technicians who have the proper tools, equipment, and training to correctly and safely maintain your vehicle. These procedures should not be attempted by "do-it-yourselfers," and you should not assume this bulletin applies to your vehicle, or that your vehicle has the condition described. To determine whether this information applies, contact an authorized Acura automobile dealer.

## DIAGNOSIS

Drive the vehicle to confirm the source of the noise. Insert a **business card** or your finger, between the steering wheel spoke and airbag module on the side making the noise.

- If the noise stops or changes, continue to **REPAIR PROCEDURE**.
- If the noise does not change, this bulletin does not apply. Continue with normal troubleshooting.

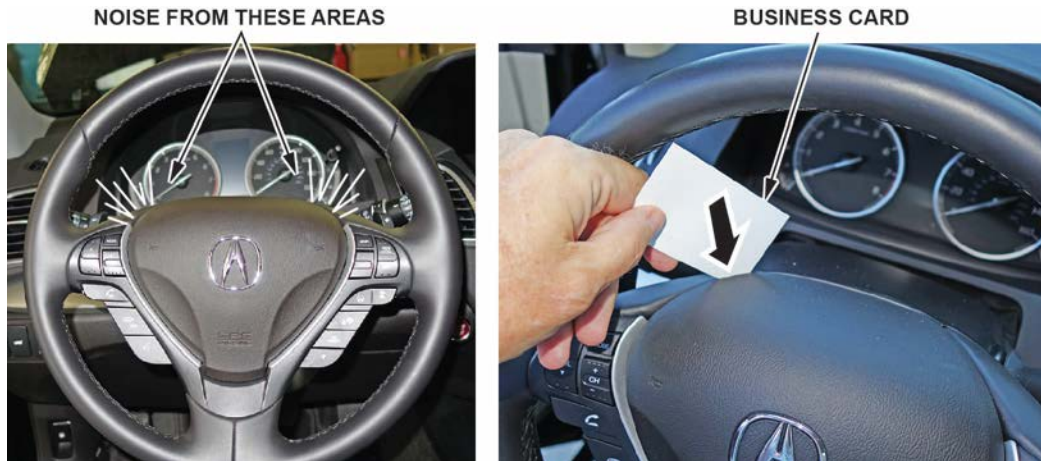

## REPAIR PROCEDURE

1. Disconnect the negative cable from the battery. Refer to the battery terminal disconnection procedure in the service information. Then, wait at least 3 minutes before starting work.
2. Remove the access panel.

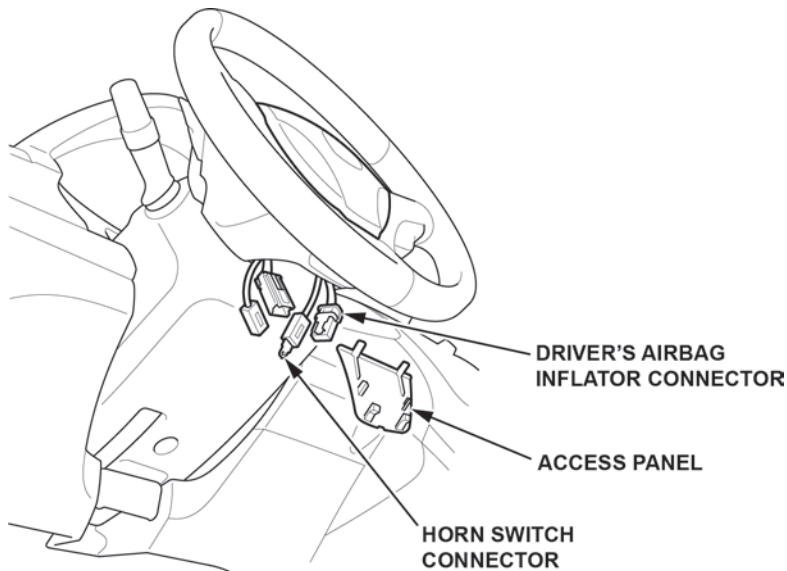

3. Disconnect the driver's airbag inflator connector on the cable reel harness.
4. Disconnect the horn switch connector.

5. Remove the T30 Torx bolts, then remove the driver's airbag module.

NOTE: Make sure the terminal tab on the horn switch connector is still attached to the airbag side (as shown) when removing the driver's airbag module.

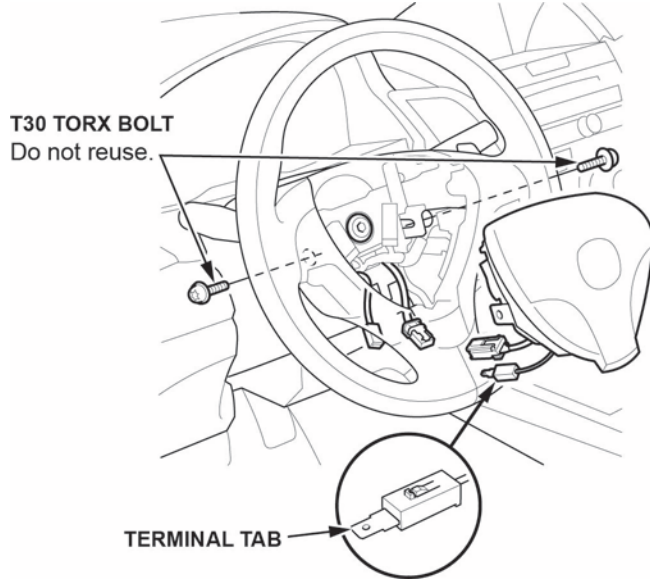

6. Using a silver Sharpie pen or equivalent, scribe marks along the bottom edge of the leather fabric at 30 mm, 50 mm, and 65 mm as shown. Do this on both the right and left side spokes.

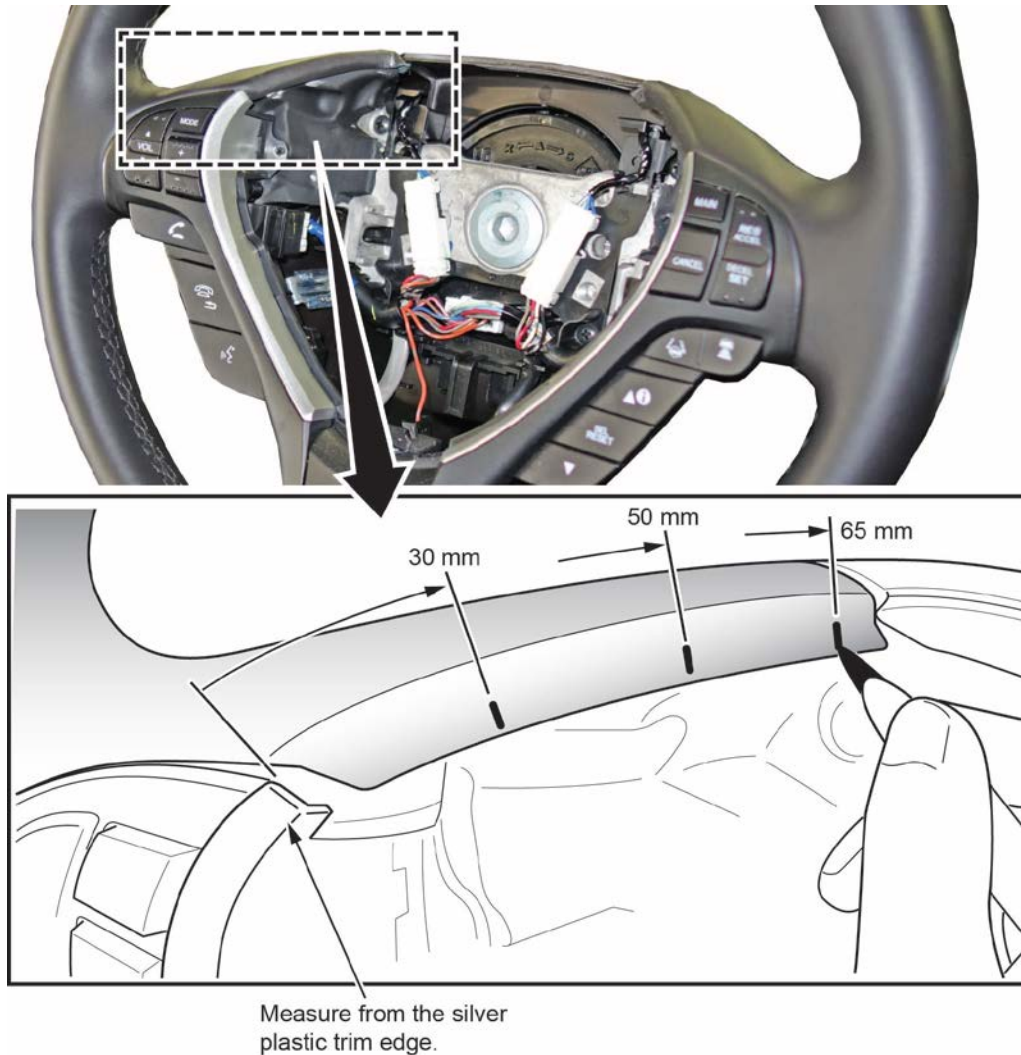

7. Measure 6 mm from the top edge of the spoke down towards the bottom of the leather material, and scribe marks at 30 mm, 50 mm, and 65 mm. Do this on both the right and left side spokes.

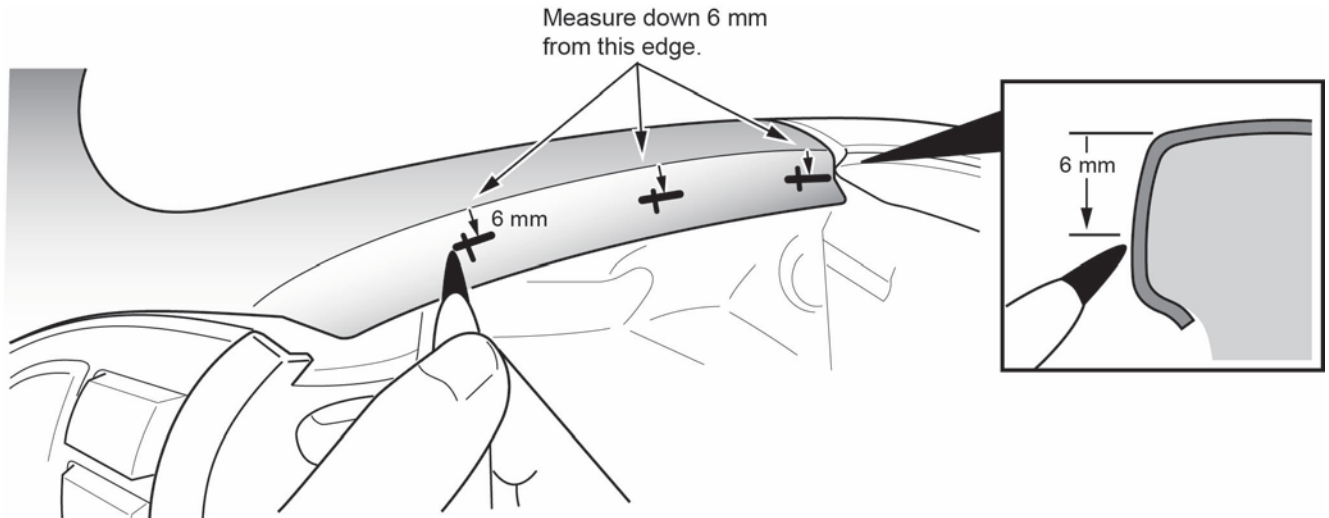

8. Connect the marks to draw a rectangle. Do this on both the right and left side spokes.

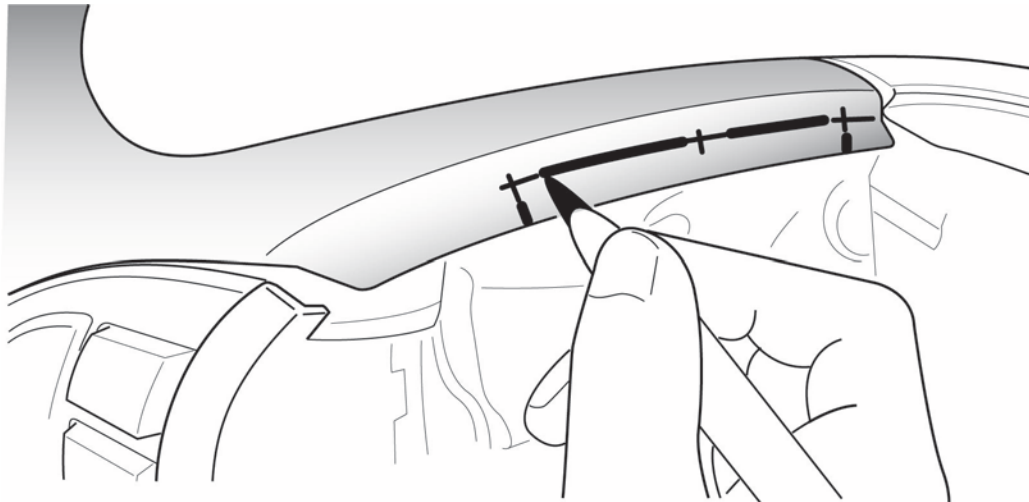

9. Using a new flat razor blade, cut out the rectangle to remove the excess leather material from the steering wheel on both the right and left side spokes.

NOTE: Once the cut section is removed, clean off any residual pen markings from the leather on the steering wheel. **If the proper amount of material is not removed, it can result in a comeback.**

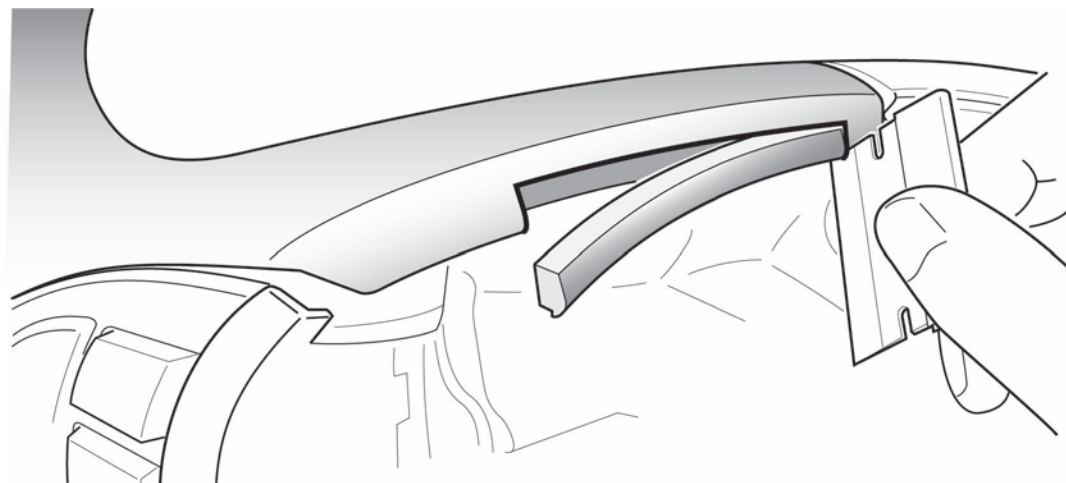

10. Install the driver's airbag module with the new T30 Torx bolts. Torque bolts to **9.4 N·m (6.9 lb-ft)**.

NOTE: Make sure the clearance between the steering wheel and horn pad is the specified value.

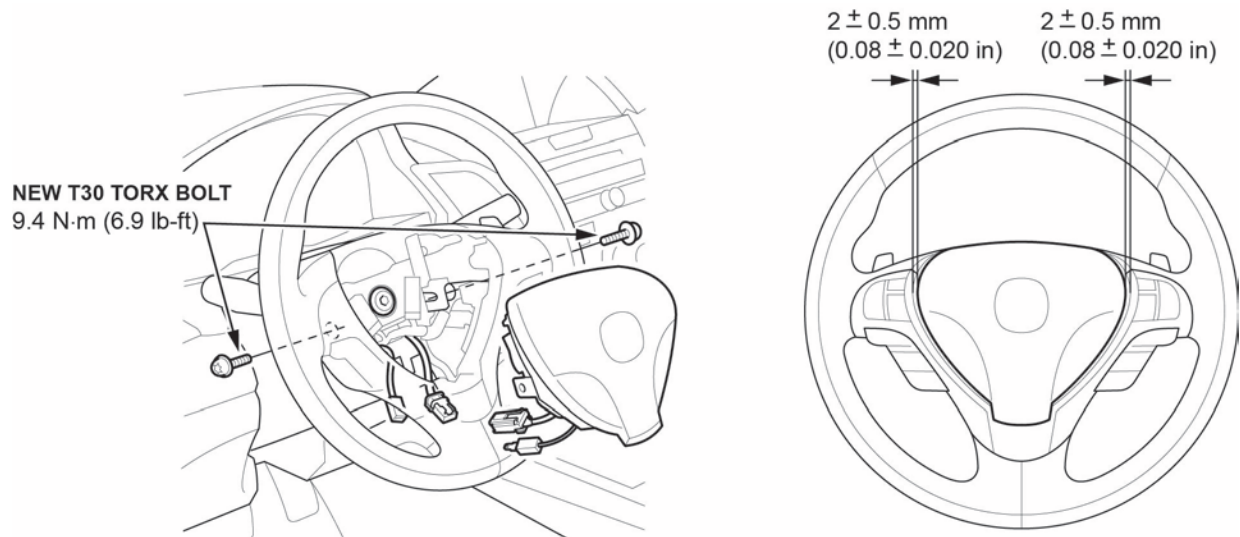

11. Connect the driver's airbag inflator connector on the cable reel harness.

12. Connect the horn switch connector.

NOTE: After connecting the negative cable to the battery, make sure the horn works properly.

13. Install the access panel.

14. Connect the negative cable to the battery. Refer to the battery terminal reconnection procedure in the service information.

END