

Technical Service Bulletin Number
--

TSB150104



Technical Service Bulletin

Subject

High Pressure Fuel Pump Performance Test and New Service Tool to Assist in Troubleshooting Fault Code 559

Warranty Statement

The information in this document authorizes specific changes to the repair practice for failures covered under product warranty coverages.

Contents

Product Affected

- ISL9 CM2350 L101
- ISL9 CM2350 L111
- ISX12 CM2350 X102
- ISX15 CM2250 SN
- ISX15 CM2250
- ISX15 CM2350 X101
- PowerGen QSX15 CM2250 ECF
- QSL9 CM2350 L102
- QSL9 CM2350 L118
- QSX15 CM2250 ECF
- QSX15 CM2350 X105
- QSX15 CM2350 X106

Description of Change

This document announces the High-Pressure Fuel Pump Performance Test, which is an

improved procedure for high pressure fuel pump diagnostics when troubleshooting Fault Code 559.

The High-Pressure Fuel Pump Performance Test will:

- Replace the High-Pressure Fuel Pump Return Flow Test in the Fault Code 559 troubleshooting tree.
- Test both the fuel volume and fuel pressure capabilities of the high pressure fuel pump at the same time.

Service Tool Availability

Completion of High-Pressure Fuel Pump Performance Test requires the new fuel pump performance test kit. See Table 1 below for parts numbers.

Contact your local Cummins® Distributor with questions.

Table 1, Fuel Pump Performance Test Kits			
Product	Kit Part Number	Part Kit Detail Description	Part Number
ISX15/QSX15	5299721	Tester, Fuel Pump (Figure 1, Item 1)	5299753
		Hose, Leak Test (Figure 1, Item 2)	3164673
ISX12 and ISL9/QSL9	5299726	Tester, Fuel Pump (Figure 1, Item 1)	5299754
		Hose, Leak Test (Figure 1, Item 2)	3164673

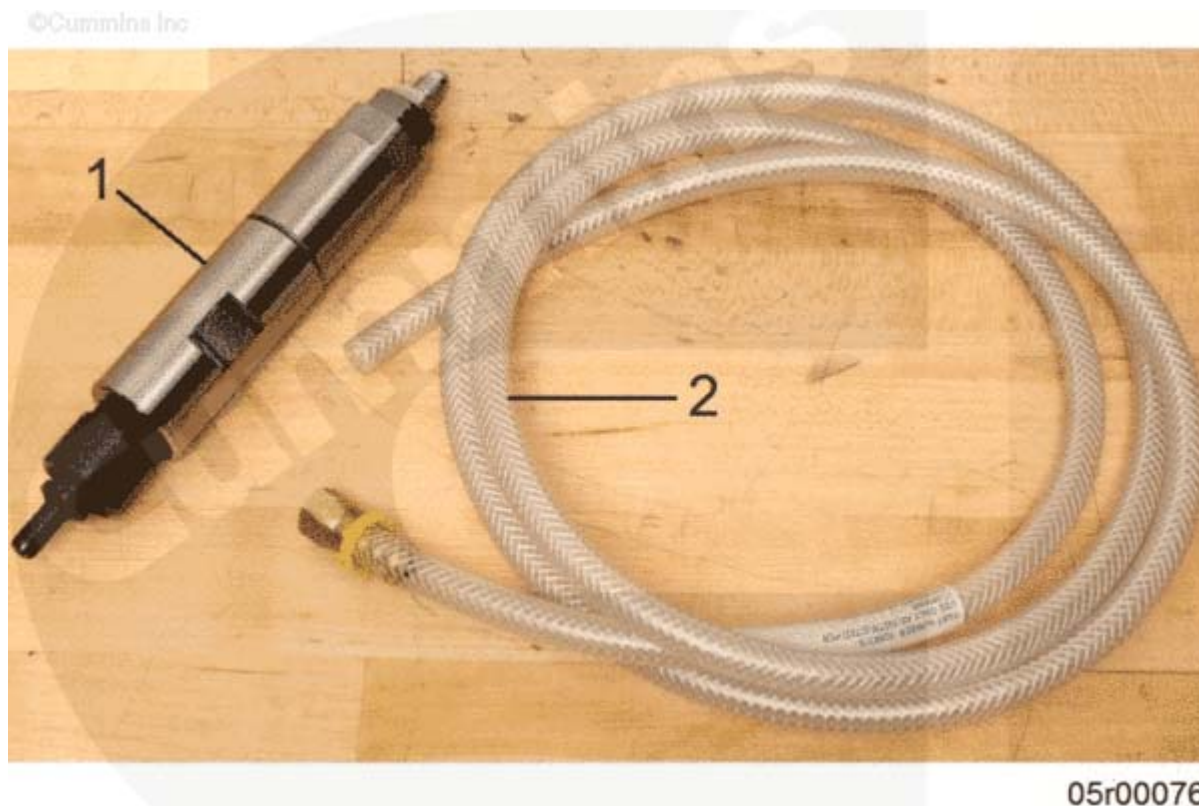

Figure 1, Fuel Pump Performance Test Kit.

▲ CAUTION ▲

When **not** in use, the fuel pump performance test service tool **must** be stored in a clean environment. Do **not** disassemble the fuel pump performance test service tool as it can be damaged by dirt or debris.

Service Instructions

A video of the following service procedure is located on QuickServe™ Online. See the video link below.

NOTE: <http://tsb.cumminsvirtualcollege.com/tsb150104.aspx>

If a shop possesses the new fuel pump performance test service tool, reference the service procedure below for instructions on how to complete the High-Pressure Fuel Pump Performance Test.

High-Pressure Fuel Pump Performance Test

Initial Setup

If the low pressure fuel system is degraded or the fuel pressure relief valve leakage is out of specification, this High-Pressure Fuel Pump Performance Test will **not** provide accurate results.

Troubleshoot the low pressure fuel system and any high pressure fuel system leakage before performing High-Pressure Fuel Pump Performance Test.

Preparatory Steps

WARNING

Normal engine operation creates highly pressurized fuel in the fuel line which will remain in the fuel line after engine shutdown. Never open the fuel system when the engine is operating. Before servicing the fuel system, always loosen the pump-to-rail fuel line at the rail to vent the pressure. Keep hands clear of the line when loosening. High-pressure fuel spray can penetrate the skin, resulting in serious personal injury or death.

WARNING

High pressure fuel spray can cause serious injury or death.

WARNING

Depending on the circumstance, diesel fuel is flammable. When inspecting or performing service or repairs on the fuel system, to reduce the possibility of fire and resulting severe personal injury, death, or property damage, never smoke or allow sparks or flames (such as pilot lights, electrical switches, or welding equipment) in the work area.

Before servicing the high-pressure fuel system, loosen the pump to rail line at the rail to vent the fuel pressure. See Figure 2 and Figure 3 below.

NOTE: A machined slot in this fitting directs the fuel spray towards the engine.

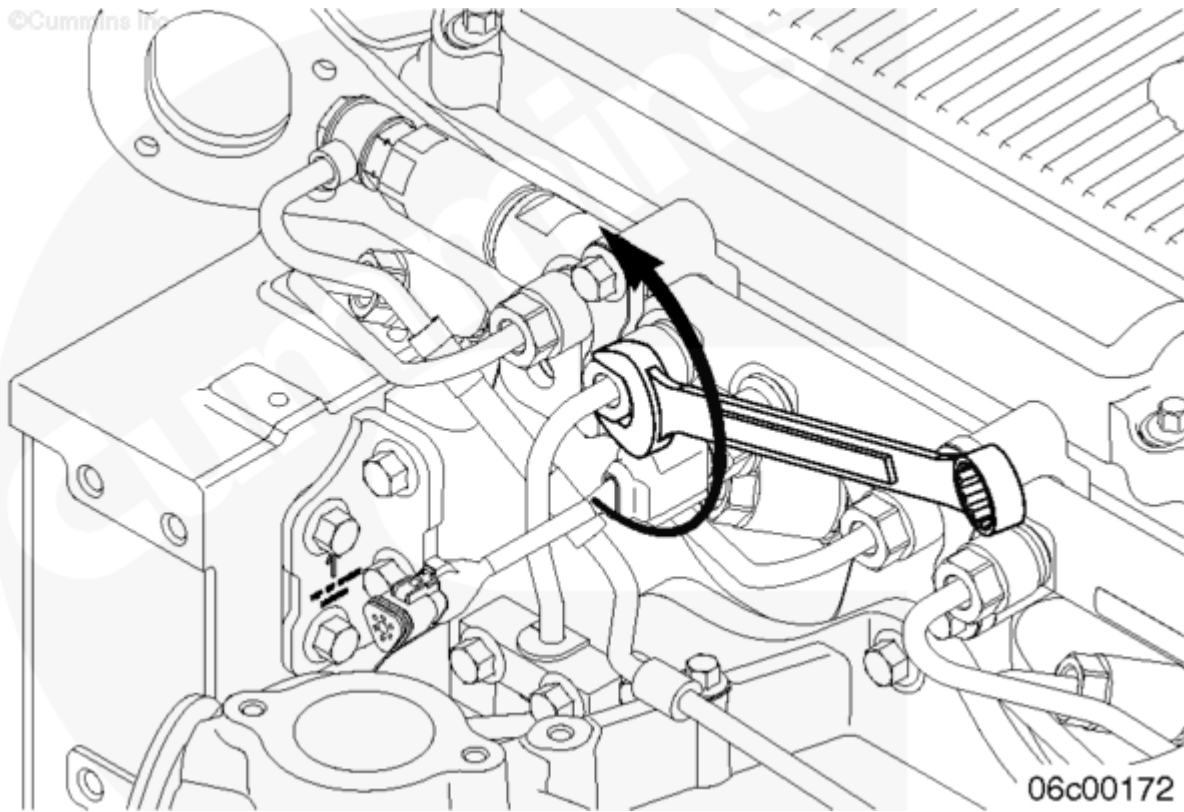

Figure 2, ISX/QSX Loosening Pump-To-Rail Line at Fuel Rail to Vent Pressure.

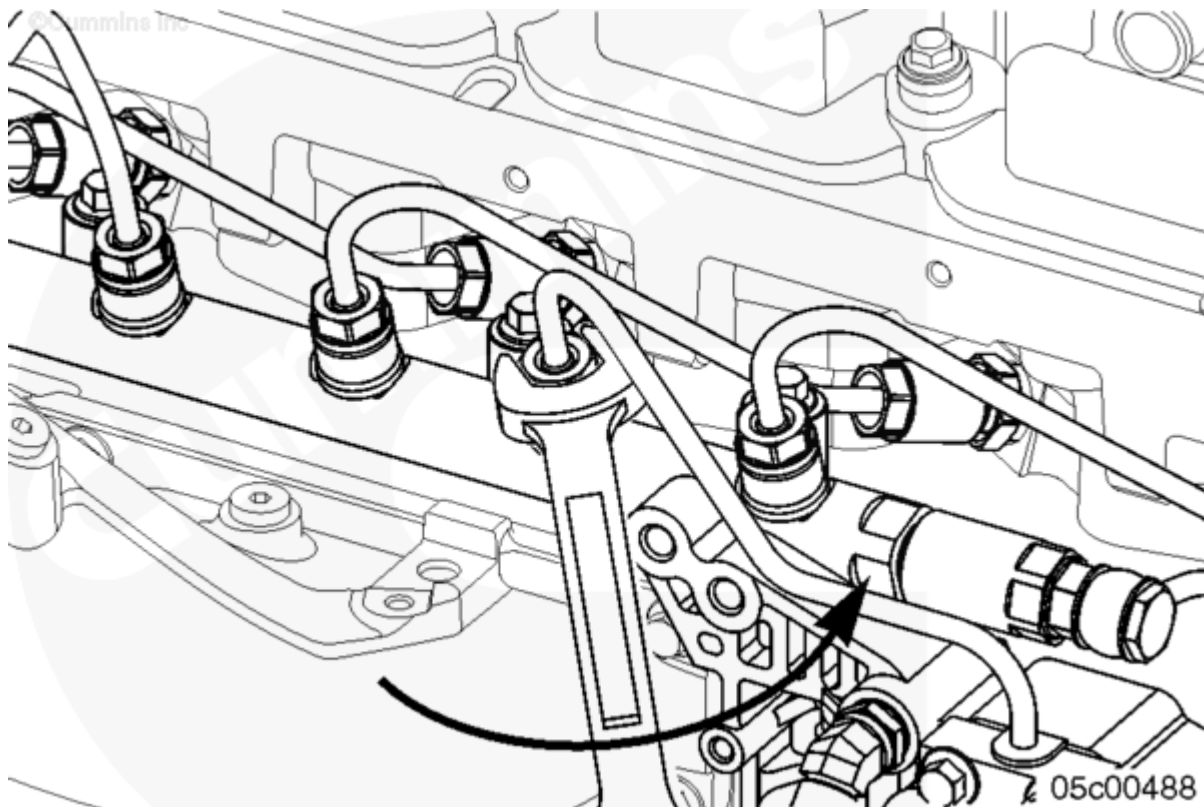

Figure 3, ISL/QSL Loosening Pump-To-Rail Line at Fuel Rail to Vent Pressure.

Tighten the fuel rail nut.

ISX/QSXCM2250 and CM2350 (All Versions) **Torque Value:** 47 N•m [35 ft-lb]

ISL/QSL CM2350 (All Versions) **Torque Value:** 65 N•m [48 ft-lb]

CAUTION

Do **not** install the fuel system leak tester tool at the high-pressure pump outlet fitting. Severe engine damage will result. This tool can **only** be installed at the fuel rail for the purpose of isolating the high-pressure fuel supply from individual fuel injectors

WARNING

When servicing the engine do not use the starting motor to rotate the engine with a high-pressure fuel system joint open. Rotating the engine can create highly pressurized fuel in the fuel system. High-pressure fuel spray can penetrate the skin, resulting in serious personal injury or death.

This test requires five fuel system leak tester tools, See required part number information and Figure 4 below.

Block off five injectors at the fuel rail in place of the high-pressure fuel line. Keep the injector line supply port that is most accessible unblocked.

Table 2, Isolation Tool Torque by Product		
Product	Isolation Tool Part Number	Torque Value
ISX/QSX15 CM2250 and CM2350 (All Versions)	4919546	47 N•m [35 ft-lb]
ISX12 CM2350 X102	4918563	47 N•m [35 ft-lb]
ISL/QSL CM2350 (All Versions)	4918563	65 N•m [48 ft-lb]

©Cummins Inc

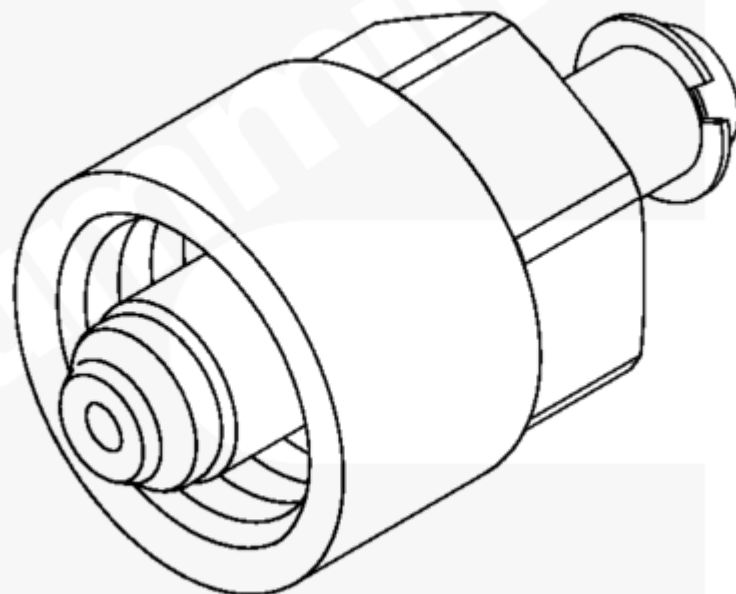

05c00399

Figure 4, Fuel System Leak Tester

Install the indicated fuel pump performance test service tool from Table 1, Part Number(s) 5299753 or 5299754 (See Figure 1, Item 1), at the unblocked fuel rail connection.

Table 3, Fuel Pump Tester Tool Torque by Product		
Product	Fuel Pump Tester Tool Part Number	Torque Value
ISX/QSX CM2250 and CM2350 (All Versions)	5299753	47 N•m [35 ft-lb]
ISL/QSL CM2350 (All Versions)	5299754	65 N•m [48 ft-lb]

Measurement



Do **not** crank the engine for 30 seconds continuously. Crank the engine in intervals with a 15 second pause between intervals. This reduces the possibility of overheating the starting motor.

NOTE: If necessary, use a battery charger to maintain proper cranking speed. Units equipped with starter lockout features may require additional cranking aids.

Engine cranking speed **must** be above 130 rpm.

1. With the following conditions met:
 - Fuel drain line, Part Number 3164673 (Figure 1, Item 2), connected to high-pressure fuel pump service tool, Part Number 5299753 (See Figure 1, Item 1).
 - Fuel pump actuator disconnected from electrical harness.
 - Injector pass-through harness disconnected from engine wiring harness.
2. Route the hose, Part Number 3164673, into a graduated beaker, Part Number 4919139, for measurement.
3. Connect INSITE™ electronic service tool.
4. Log Engine Speed and Fuel Rail Pressure Measured with INSITE™ electronic service tool.
5. Initial Purge
 - Crank engine until fuel flow exits the hose or for a maximum of 15 seconds. If no fuel flow exists the hose after three 15 second crank cycles, inspect the fuel pump head. See the corresponding Service Manual. Reference Procedure 005-227 Fuel Pump Head in section 5.
 - Discard purged fuel from service tool hose in accordance with local and environmental regulations.
6. 30 Second Fuel Volume Measurement – Two 15 second crank cycles. (Measurement begins **only** after the fuel pump performance test service tool opens. When open, a pressure pulse can be heard and felt through the high-pressure fuel pump service tool).
 - Collect the fuel that exits the high-pressure fuel pump service tool during the initial 15 second measurement cycle.
 - Allow the starting motor to cool for 15 seconds.
 - Repeat the 15 second measurement cycle.
 - Sum and collect the total fuel volume exiting the high-pressure fuel pump service tool during the initial/final 15 second measurement cycles.
7. Record the average engine cranking speed from INSITE™ electronic service tool logging results.

NOTE: After completing the high-pressure fuel pump performance test, fuel may remain in the drain line. Empty the remaining fuel in line into measuring container to obtain a proper measurement.

- Fuel volume from the high-pressure fuel pump service tool is directly related to engine speed.
- See graphs, Figure 5, 6 and Figure 7 below, to determine the minimum fuel volume from the high- pressure fuel pump service tool.
- For all ISX/QSX CM2250 and CM2350 engines, see Figure 5 and Figure 6 below.
- For all ISL/QSL CM2350 engines, see Figure 7 below.

For Figures 5 and 6 below:

- Engine speed in rpm can be found on the horizontal axis. This is the average engine RPM over 30 seconds (two 15 second crank cycles).

- Service tool fuel volume in milliliters can be found on the vertical axis. This is the volume collected over 30 seconds. (two 15 second crank cycles).

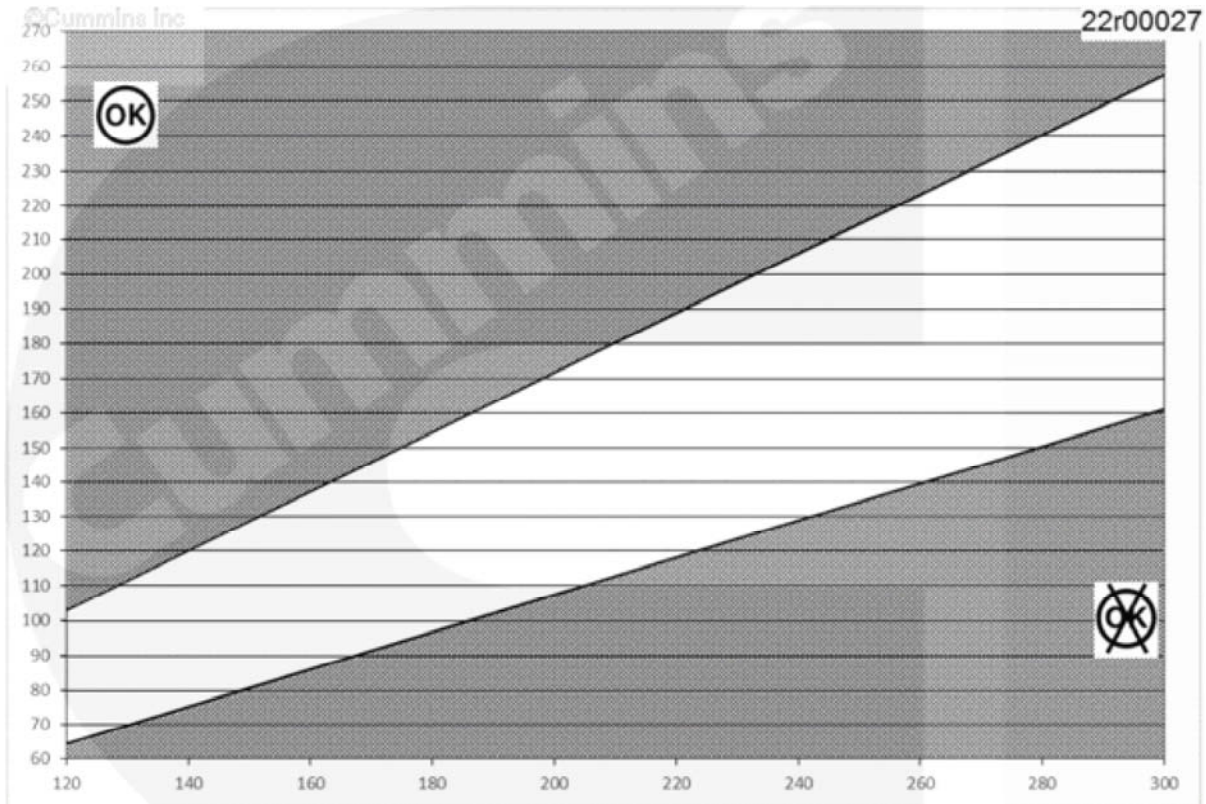

Figure 5, Engine Speed [rpm] Versus Service Tool Fuel Volume [ml] for All ISX/QSX CM2250 Engines.

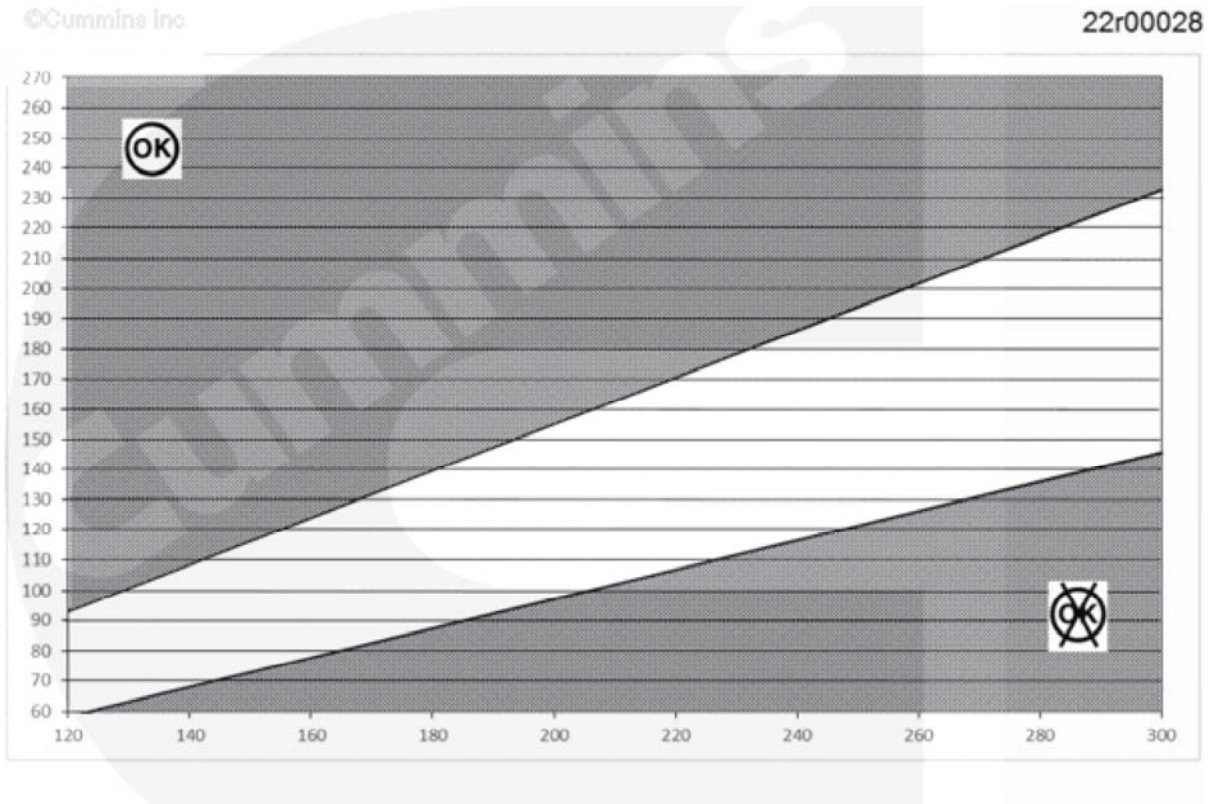

Figure 6, Engine Speed [rpm] Versus Service Tool Fuel Volume [ml] for All ISX/QSX CM2350 Engines.

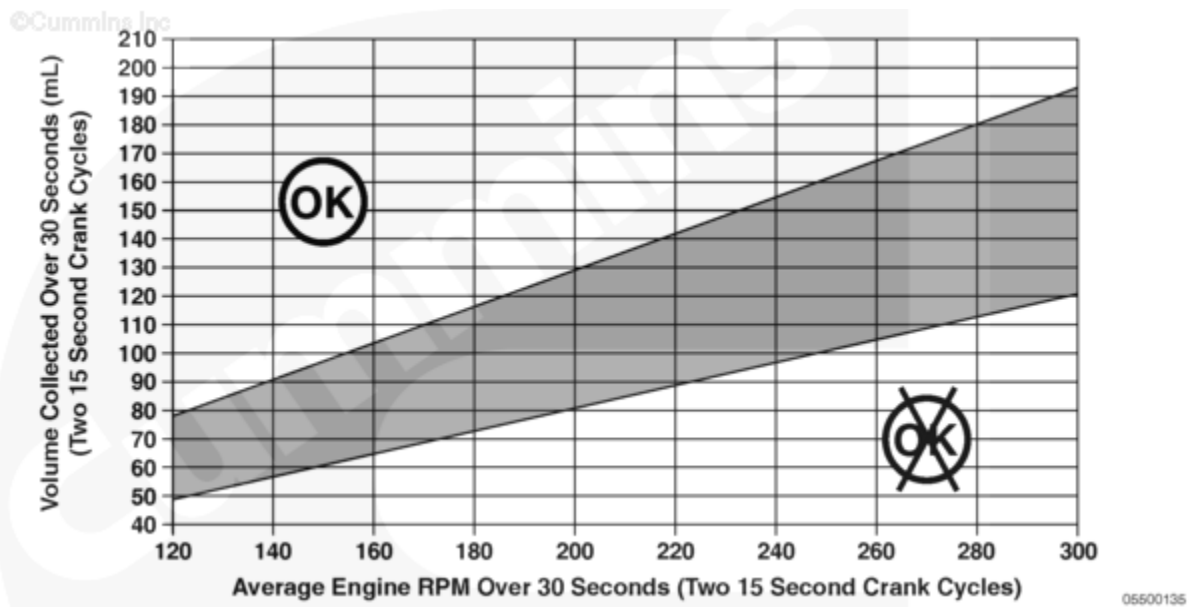

Figure 7, Engine Speed [rpm] Versus Service Tool Fuel Volume [ml] for All ISL/QL CM2350 Engines.

Scenario 1

If the measured fuel volume from the high-pressure fuel pump service tool at the recorded engine speed is in the upper shaded region of the graph, the fuel pump is functioning properly.

Scenario 2

If the measured fuel volume from the high-pressure fuel pump service tool at the recorded engine speed is in the lower shaded region of the graph, the fuel pump is **not** functioning properly and **must** be replaced.

Scenario 3

If the measured fuel volume is in the unshaded part of the graph then verify the following:

- Correct specifications are being used.
- Proper high-pressure fuel pump service tool installation.
- That there are no external leaks.
- That all low pressure system checks were made, and then perform the high pressure fuel pump performance test again.

If the test readings are still in the unshaded area, the fuel pump head **must** be removed and the fuel pump camshaft and fuel pump camshaft tappets rollers **must** be inspected. If the fuel pump passes the visual inspection, contact technical support.

Finishing Steps

- Remove the test equipment.
- Install the fuel injector supply lines. Follow the installation sequence outlined in the fuel rail installation procedure. See the corresponding Service Manual. Reference Procedure 006-060 Fuel Rail in section 6.
- Connect the fuel pump actuator electrical connector.
- Connect the injector pass-through electrical connector(s).

Document History

Date	Details
2015-6-26	Module Created
2015-7-7	none
2015-7-9	Non-Product Problem Solving (PPS)
2015-7-15	Product Problem Solving (PPS)
2015-8-17	Format changes.
2016-5-5	Updated Step 5 and 6 and Figure 4 and 5 axis explanations. Added Figure 7.
2016-7-25	Added Table 2 and Table 3

Last Modified: 01-Aug-2016