

	Date	Group	No.	Release	Page
This Field Service Bulletin replaces bulletin "PV729-FSB257-004_M, CCV Housing Inlet, Replacement" (USA76280) dated 6.2016.	9.2016	257	004	02	1(3)

CCV Housing Inlet Tube, Replacement
MP7 US14, US15
CXU, GU LEU, LR, MRU

FSB 257-004, CCV Housing Inlet Tube, Replacement

(September 2016)

MACK Trucks has received reports from the aftermarket regarding oil leaks at the CCV housing inlet tube and at the split line between the upper and lower housings on chassis builds between January 1, 2014 and January 26, 2016 with MP7 engines. It has been determined that the O-ring installed on the inlet tube is the source of the leak and oil may leak down the back of the housing giving the impression that the housing split line is also leaking.

Should there be a report of this nature on a chassis built within the affected date range, do not disassemble the CCV. Replace the inlet tube with part number 22858726. Clean the surrounding area to complete the repair. If it is determined that there is a leak at the housing other than the inlet O-ring, the complete CCV assembly will need to be replaced as this is a non-serviceable part. Do not attempt to tighten the split line screws on the housing or disassemble the assembly as seals and repair parts are no longer available for this component as they were on the older version of this component. If the collar on the CCV inlet is worn or broken at the locking lip, replace the complete CCV assembly. Additionally, Replace the CCV to cylinder block gasket any time the CCV assembly is removed.



W2111722

Procedure

You must read and understand the precautions and guidelines in Service Information, Function Group 20, Engine Safety Practices, before performing this procedure. If you are not properly trained and certified in this procedure, ask your supervisor for training before you perform it.

- 1 Secure the vehicle for service by parking it on a flat level surface, applying the parking brake, chocking the rear wheels, and placing the transmission in neutral or park.
- 2 Remove the quick connect fitting at the CCV.

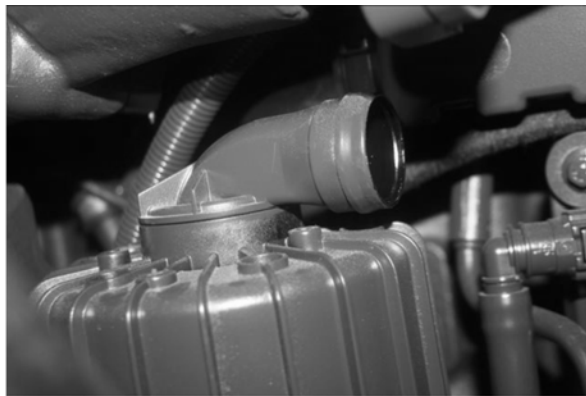

W2111720

- 3 Remove the formed rubber hose from the metal ventilation pipe coming from the valve cover.

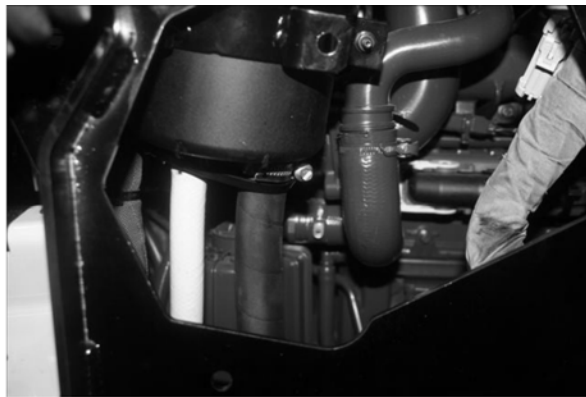

W2111721

- 4 Inspect the connection at the CCV for damage.
- 5 Connect the replacement hose to the CCV and position on metal ventilation pipe.

6 Tighten the clamp securing the rubber hose to the metal pipe to 4 ±0.6 Nm (35 ±5 in-lb).

Note: If a leak still present and / or the ventilation pipe is cracked, replace the CCV.

Note: Replace the CCV to cylinder block gasket any time the CCV assembly is removed.

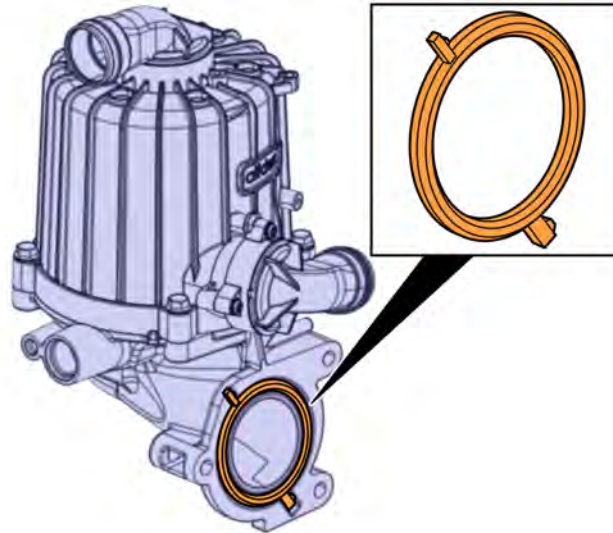

W2115279

7 Remove the wheel chocks.

Reimbursement

This repair may be eligible for reimbursement if a product failure was experienced within time and mileage limits of the applicable Warranty coverage. Reimbursement is obtained via the normal claim handling process.	
Claim Type (used only when uploading from the Dealer Bus. Sys.)	01
Labor Code	
Primary Labor Code	2574-03-09-01 0.3 hrs.
Causal Part	21679517, 22011638

Mack Trucks Inc. reserves the right to make any changes in design or to make additions to or upon its products without incurring any obligations to install the same on vehicles previously built.