



Service Bulletin

File in Section: -
 Bulletin No.: 16-NA-265
 Date: August, 2016

TECHNICAL

Subject: Dead Battery and/or Service Rear Axle Message Displayed

Brand:	Model:	Model Year:		VIN:		Engine:	Transmission:
		from	to	from	to		
Cadillac	XTS	2016	2016				M7U

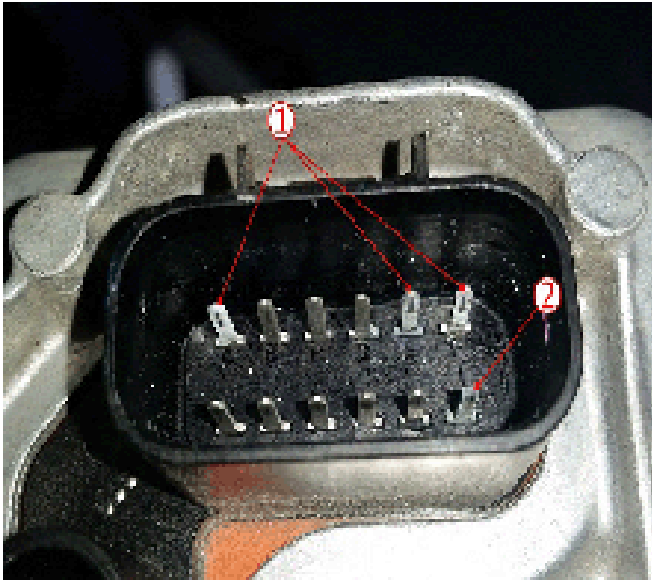
Involved Region or Country	North America and N.A. Export Regions
Additional RPOs	UGN
Condition	<p>Some customers may comment on the following conditions:</p> <ul style="list-style-type: none"> • Dead Battery. • Service Rear Axle message displayed. <p>The customer may also comment that the CUE screen is turning on and off after the vehicle has been shut off.</p>
Cause	<div style="text-align: center;">  </div> <p style="text-align: right; font-size: small;">4564375</p> <p>This may be caused by moisture entering the rear axle to suspension actuator wiring harness through an opening in the wiring insulator, causing corrosion (1, 2) in the K47 connector.</p>

Correction

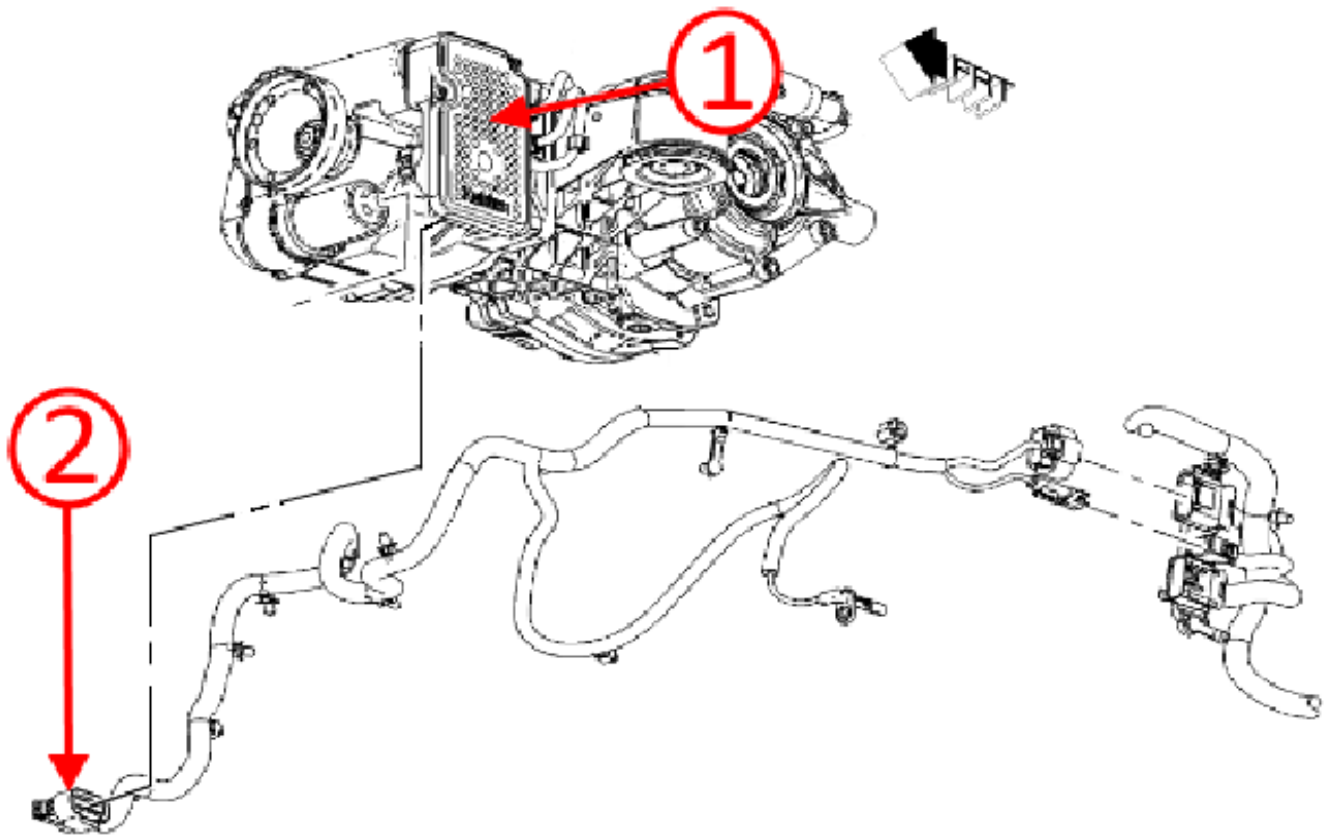

Inspect the K47 connector for corrosion. If corrosion has been found in the connector for the rear axle to suspension actuator wiring harness (2) and the rear differential clutch control module (RDCCM) (1), both components must be replaced.

4560523

Removal

1. Deflate the suspension air bags. Refer to *Air Suspension System Depressurization and Pressurization* in SI.
2. Remove the RDCCM. Refer to *Rear Differential Clutch Control Module Replacement* in SI.

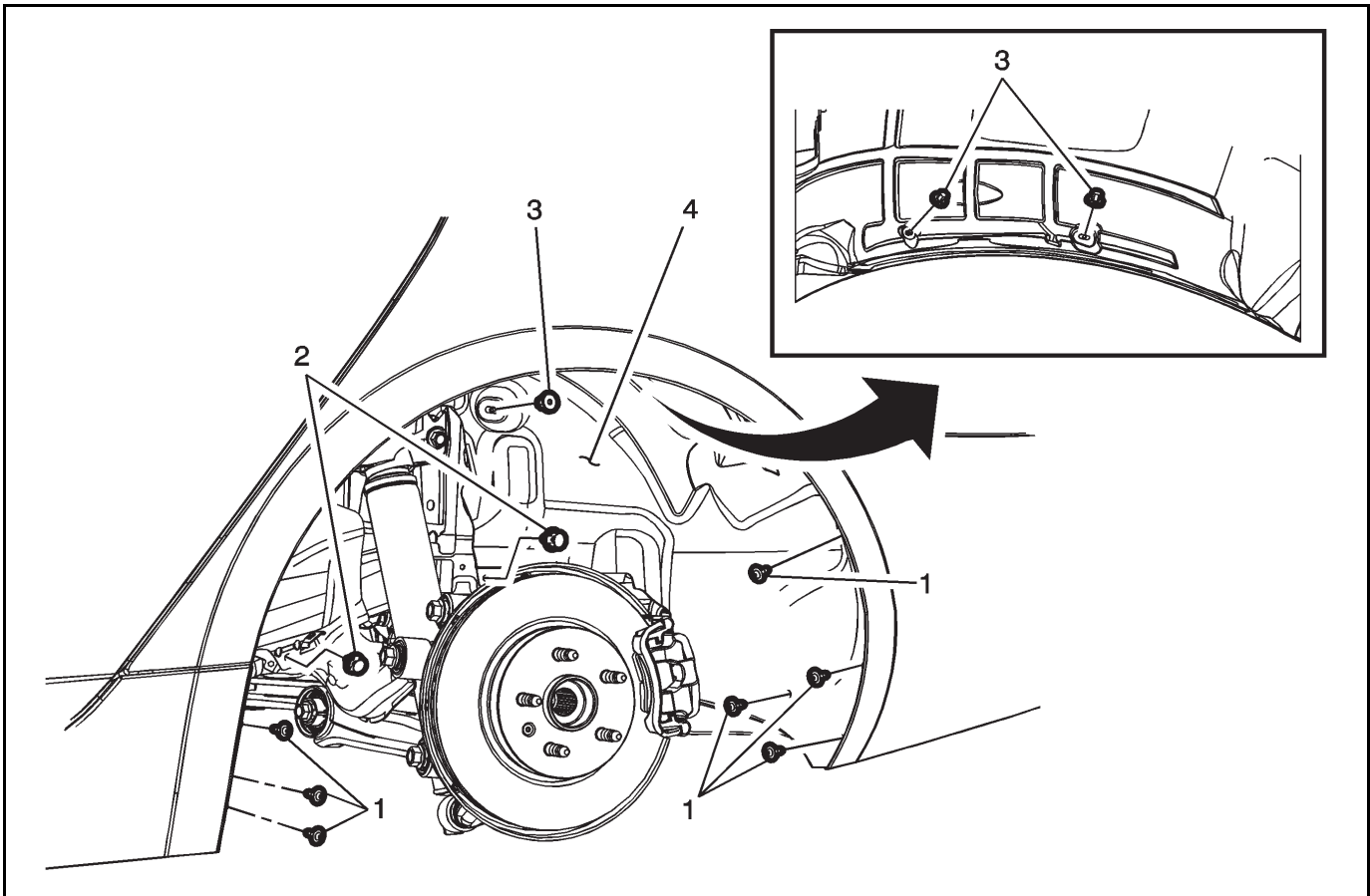

2758929

3. Remove the rear wheelhouse liner (4).

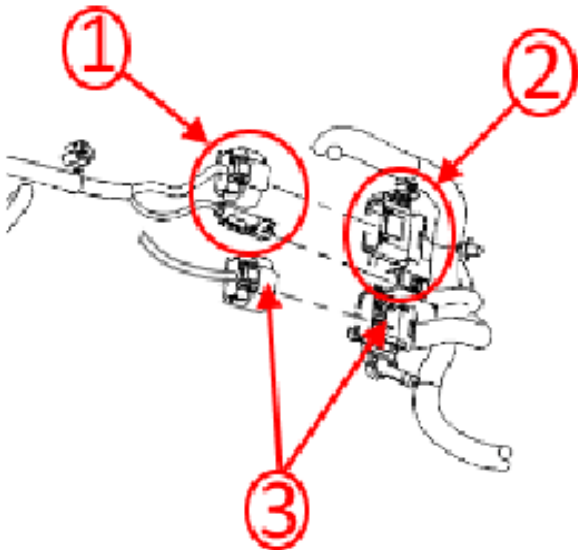

4564972

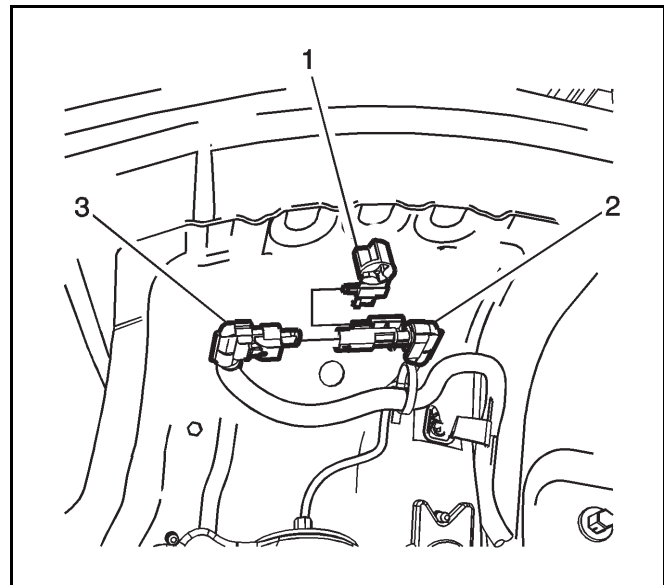

2845430

- 4. Disconnect the ABS sensor and control module electrical connectors (1) from the body side wiring harness (2).
- 5. If equipped with integrated braking assist, disconnect the electrical connector (3).
- 6. Separate the wiring harness from the body.

7. Disconnect the strut electrical connector (2) and separate the wiring harness from the body.

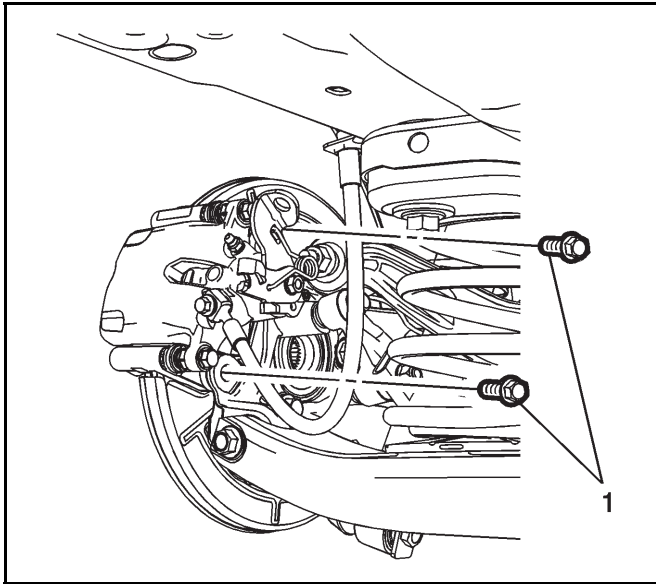

2555446

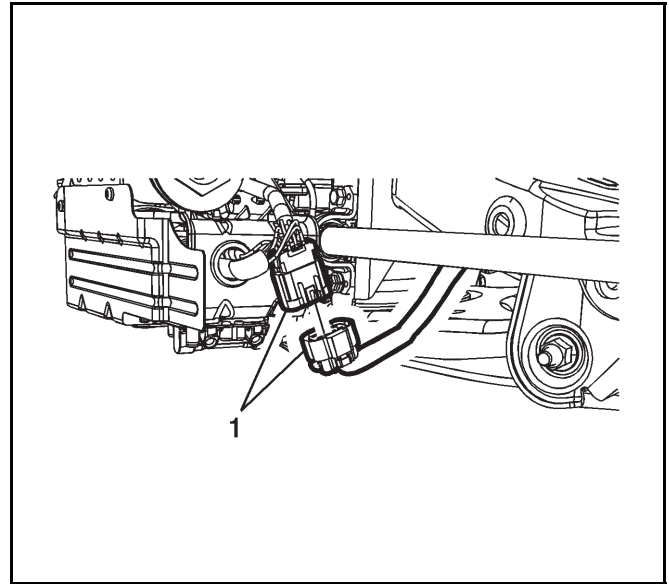

2760412

Caution: Support the brake caliper with heavy mechanic wire, or equivalent, whenever it is separated from its mount and the hydraulic flexible brake hose is still connected. Failure to support the caliper in this manner will cause the flexible brake hose to bear the weight of the caliper, which may cause damage to the brake hose and in turn may cause a brake fluid leak.

8. Remove the bolts (1) that secure the brake caliper to the caliper bracket.
9. Secure the brake caliper to the body using mechanics wire or equivalent.

12. Disconnect the air ride pump electrical connector (1).

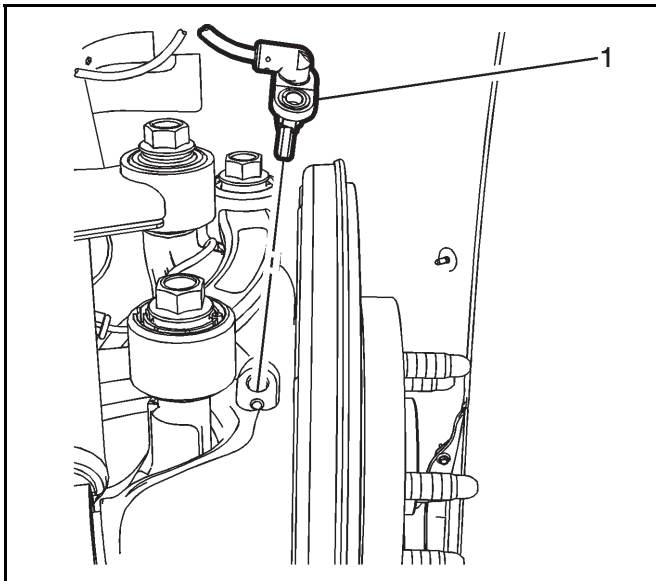

2753957

10. Remove the ABS sensor (1).
11. Separate the ABS wiring harness from the upper control arm.

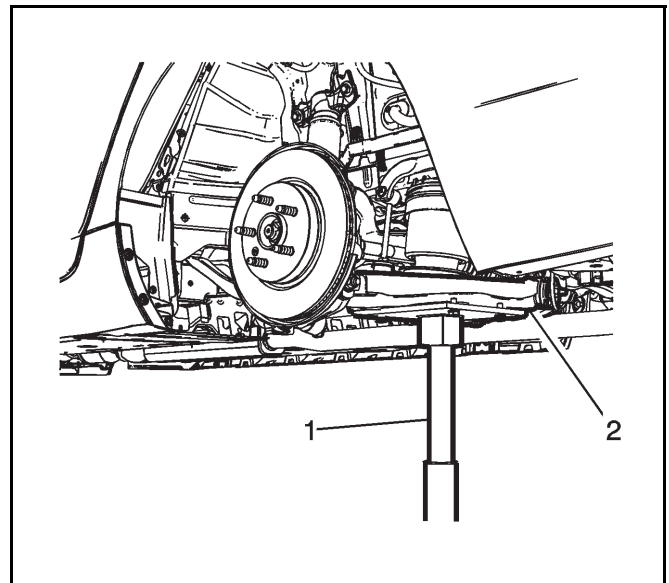

2845507

13. Support the rear cradle assembly with a support stand (1) or equivalent.

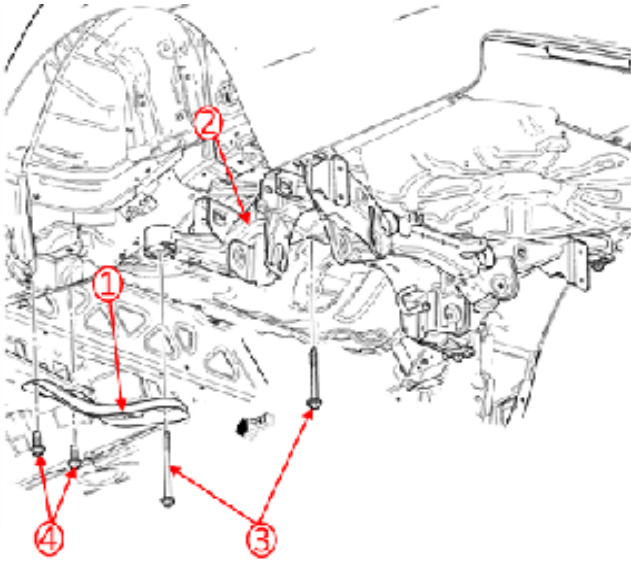

4564270

14. Remove the two left side cradle reinforcement bracket bolts (4).
15. Remove the two left side cradle bolts (3).

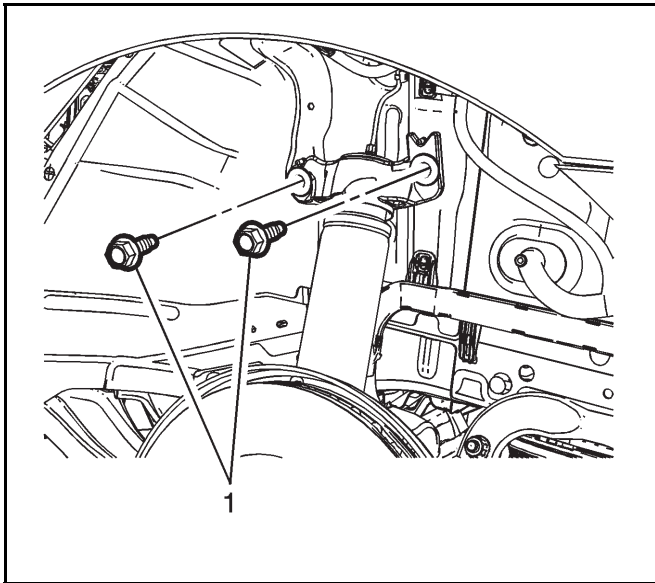

2845547

16. Remove the two upper strut bolts (1).
17. Using care, lower the cradle assembly so that only the left side is lowered.

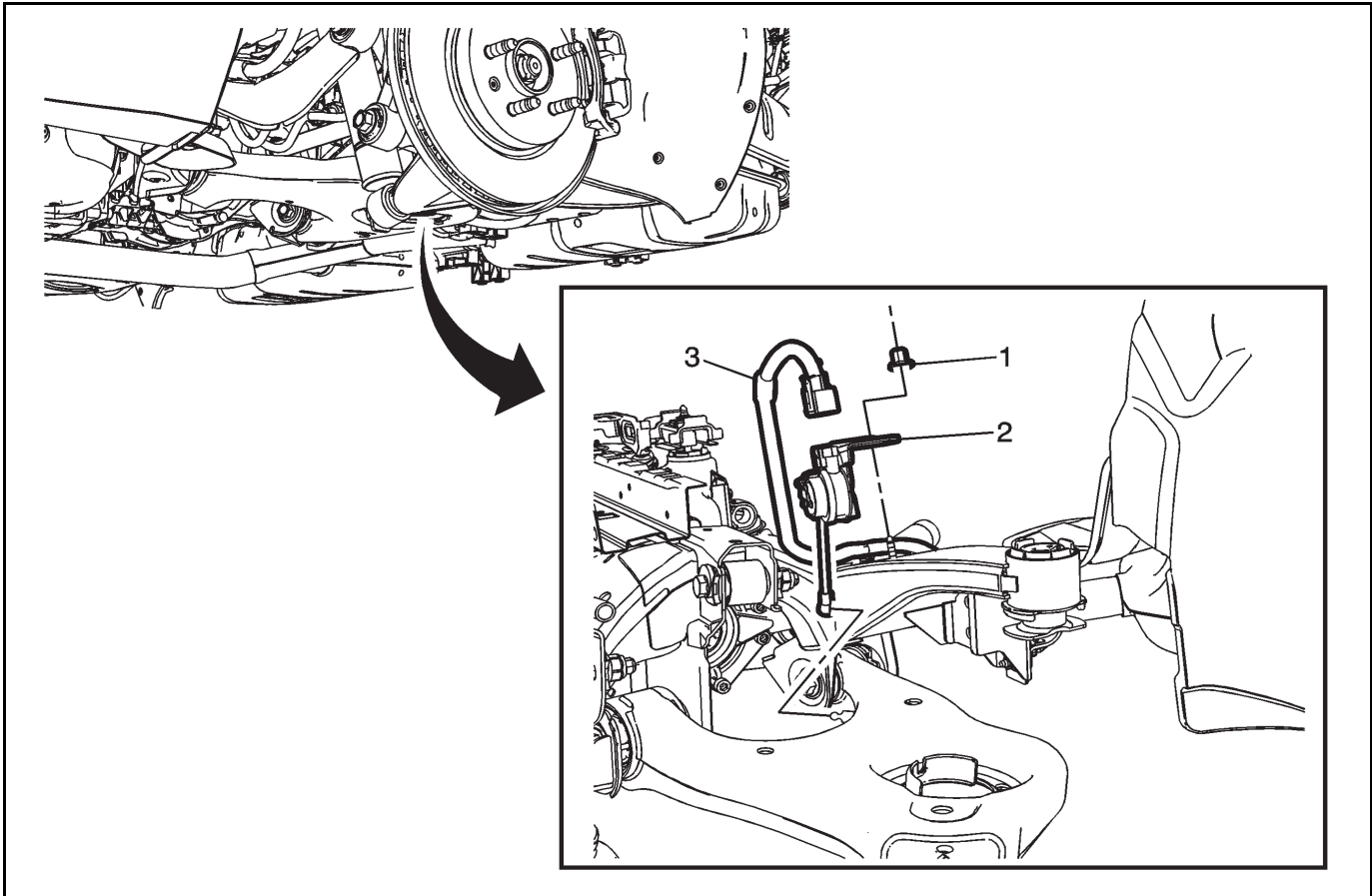

2851833

18. Disconnect the ride height sensor electrical connector (3).
19. Remove the wiring harness from the suspension cradle.

Installation

1. Route and position the wiring harness through the suspension cradle.
 2. Connect the ride height sensor electrical connector.
 3. Install the wiring harness to the suspension assembly.
 4. Using care, raise the suspension cradle into position.
 5. Install the rear cradle bolt hand tight.
 6. Position the front cradle reinforcement bracket and install the front cradle support bracket bolts hand tight.
 7. Torque the front cradle bolt and rear cradle bolts to:
 - **90 Y (60 lb ft)**
 - **plus 180 degrees**
 - **plus 15 degrees**
 8. Torque the front cradle reinforcement bracket bolts to:
 - **150 Y (111 lb ft)**
 - **plus 30 degrees**
 - **plus 15 degrees**
 9. Route the air bag pump electrical connector between the cradle and sway bar and connect.
 10. Install the ABS sensor.
 11. Using a support stand or equivalent, compress the suspension to align the strut to the body. Tighten the bolts to **100 N•m (74 lb ft)**
 12. Connect the strut electrical connector.
- Note:** When re-installing the brake caliper, it may be required to compress the caliper by turning the parking brake cable adjustment screw **clockwise** at the electric parking brake control module.
13. Install the brake caliper.
 14. Connect the ABS sensor, control module and, if equipped, integrated braking assist electrical connectors to the body side wiring harness.
 15. Install the rear wheelhouse liner.
 16. Install the RDCCM. Refer to *Rear Differential Clutch Control Module Replacement* in SI.
 17. Connect both wiring harness connectors to the RDCCM.
 18. Lower the vehicle.
 19. Re-inflate the suspension air bags. Refer to *Air Suspension System Depressurization and Pressurization* in SI.
 20. Clear the codes.

Parts Information

Description	Part Number	Qty
MODULE KIT, RR DIFF CLU CONT	23183680	1
HARNES, SUSP ACTR WRG	23459989 L With COLL IMMINENT BRK-ALL SPEED, VEH FWD MOVEMENT, BRAKE PREFILL, INTEGRATED BRAKE ASSIST	1
	23459990 L	1

Warranty Information

Labor Operation	Description	Labor Time
5480348*	Rear Differential Clutch Control Module Replacement Left side Suspension Wiring Harness	6.5 hrs
*This is a unique Labor Operation for Bulletin use only.		

Version	1
Modified	

