



Service Bulletin

File in Section: -

Bulletin No.: 16-NA-211

Date: August, 2016

INFORMATION

Subject: Information on 1st vs. 2nd Design Non-Interchangeable Shift System Parts

Brand:	Model:	Model Year:		VIN:		Engine:	Transmission:
		from	to	from	to		
Cadillac	ATS	2013	2016				Equipped with Manual Transmission (RPO M3L)

Involved Region or Country	North America and N.A. Export Regions
-----------------------------------	---------------------------------------

Interim Model Year Design Change – M3L Interlock Shift System

A change was made to the interlock components of the shifting system to increase the robustness of gear lockout when not engaged. The changes in 1st design and 2nd design components are NOT INTERCHANGEABLE.

It is possible that the same model year vehicle may have either the first or second design transmission.

Based on the transmission design level, specific parts catalog and service information needs to be referenced when repairing a unit. Use the chart below to identify the transmission design level.

Model	RPO	Transmission Assembly Number	Design Level	Applicable Service Information	Applicable Part Catalog
2013-2016 ATS	M3L	24270967 24270968 24273613 24273612 24275015 24275014 24275050 24275051 24273611 27273614 24261584 24261585	1st	Model year 2013-2015	Model year 2013-2015
2013-2016 ATS	M3L	All assembly numbers not mentioned above	2nd	Model year 2016	Model year 2016

There are 2 catalog exceptions/clarifications:

1. There are 2 parts from the 2nd design shift system that will be published in the 2013-2015 Catalog. These are only applicable to the export version of the transmission (M3L, KL9). Please read the clarification at the end of this document.
2. In the 2016 ATS M3L part catalog there are 2 main cases showing. Both of these cases are 2nd design shift system **ONLY**. The difference between the 2 cases is, one main case contains a temperature sensor and one main case does not. Please read the clarification at the end of this document.

How to Identify Transmissions:

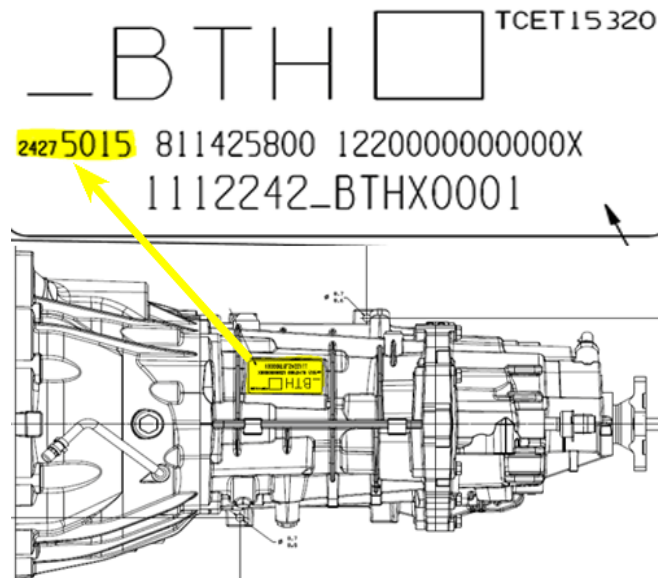

4539679

There is a barcode label on the top of the transmission. There is also a secondary ID tag on the side of the transmission held by a bolt.

If the ID tag on the transmission is not visible, the transmission design level can be identified by the identification of the following components:

1. Modified shift shaft geometry on **all shift shafts** including addition of holes through the 1st/2nd shift shaft assembly and 3rd/4th lever selector assembly.
2. Modified main case geometry and grooves for interlock pins.
3. Unique parts of the interlock concept.
4. Modified geometry of the 5th/6th gate.
5. Modified geometry to the Gear Select Lever.

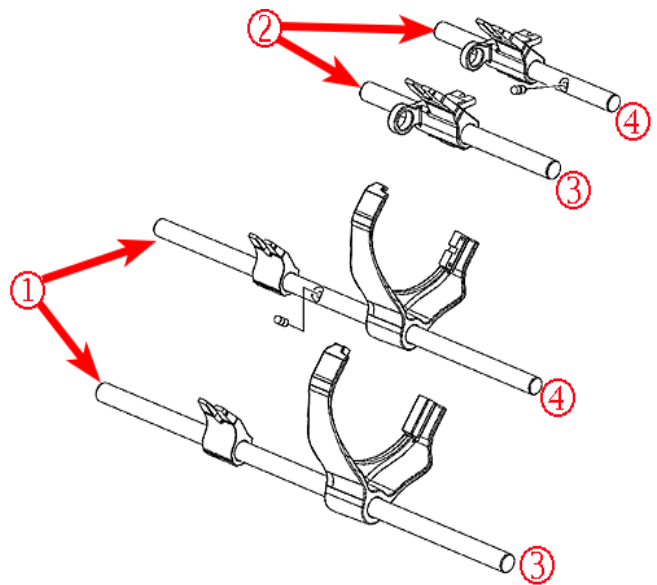

4539947

1. The geometry of the 1st/2nd shift shaft assembly (1) and the 3rd/4th lever selector assembly (2) were modified by adding through holes which house new interlock pins. In addition to this **every shift** shaft had its geometry modified by changing grooves and chamfers which makes them non-interchangeable between 1st (3) and 2nd (4) design. For service please reference the correct information and parts catalog by identifying these parts or using the provided chart.

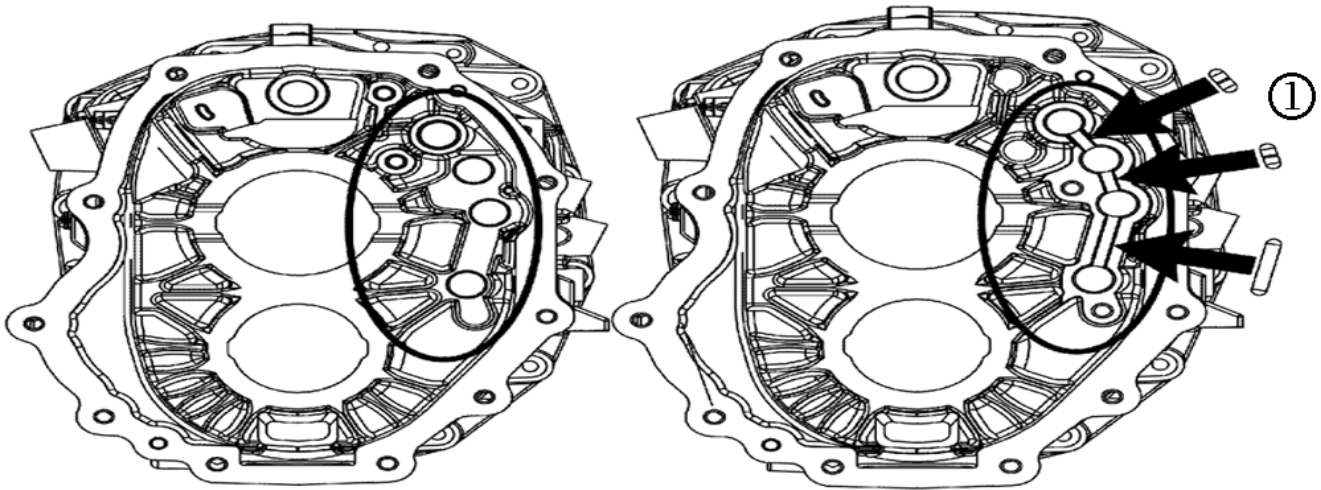

4547664

- 2. The rear divider wall of the main case has grooves (1) added which will hold interlock pins. For service please reference the correct information and parts catalog by identifying these parts or using the provided chart.

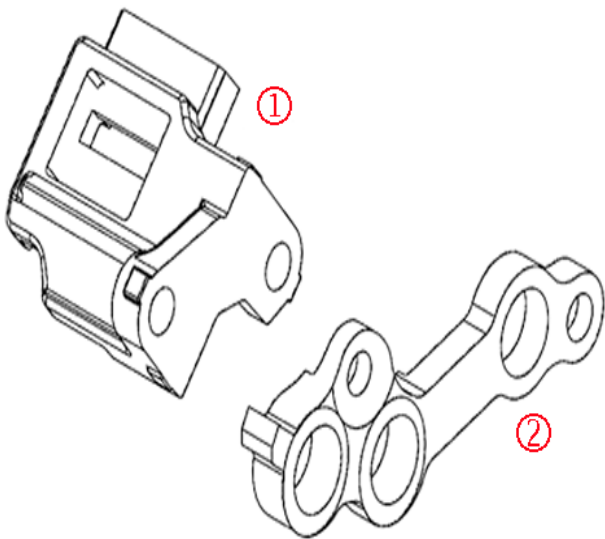

4540828

- 3. The shifting system has an interlock bracket (1st design) (1) and an interlock plate (2nd design) (2) which are bolted to the main case. Identification of these parts help determine transmission design level. For service please reference the correct information and parts catalog by identifying these parts or using the provided chart.

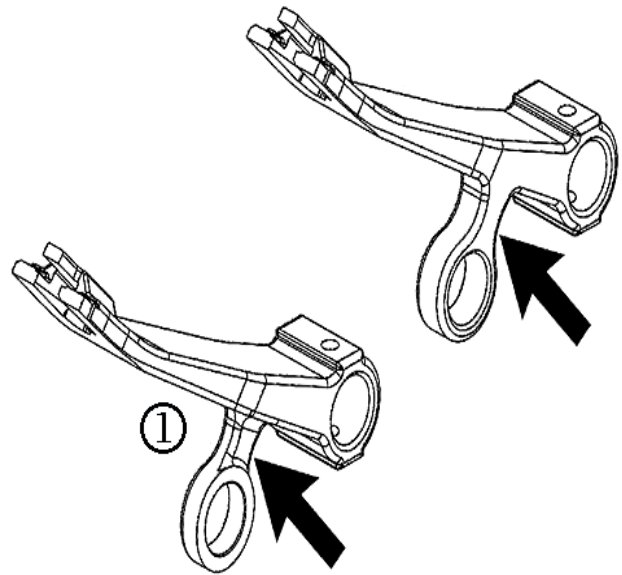

4547726

- 4. The geometry of the 5th/6th gate was modified in the area shown. A flat was created and the thickness was reduced by approximately 3.0 mm (1). For service please reference the correct information and parts catalog by identifying these parts or using the provided chart.

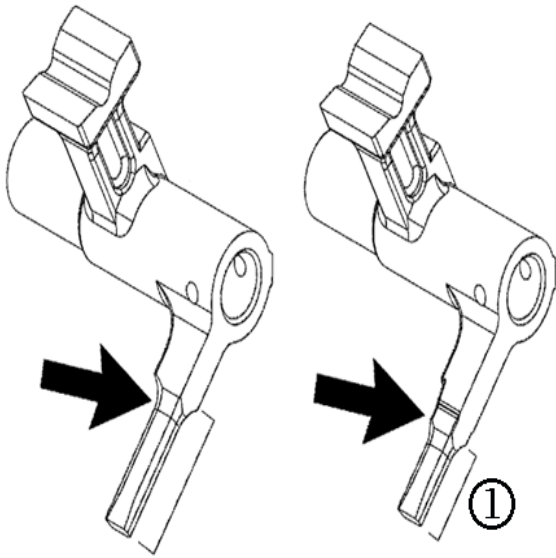

4547782

5. The gear select lever has the machined area of the cam reduced (1) as shown. For service please reference the correct information and parts catalog by identifying these parts or using the provided chart.

Exception #1: 2nd Design Export Parts found in 2013-2015 Catalog:

The below kits are **ONLY** for Export Transmissions (M3L, KL9) with the 2nd design level shift system. The chart referenced in this bulletin directs you to the 2016 parts catalog if you have a 2nd design shift system. There are 2 parts that are exceptions to this rule and they will be shown in the 2013-2015 catalog.

These kits **CANNOT** be used on the transmissions that may be identified above as being 1st design level.

- 24285683 – Shaft Asm Main (2nd Design – Trans w/ Start/Stop)
- 24285681 – Extension Asm-Trans (2nd Design – Trans w/ Start/Stop)

Exception #2: Main Case Part Clarification:

Model year 2013-2015 ATS M3L vehicles **DO NOT** have a wire harness that connects to transmission temperature sensor.

Model year 2016 ATS M3L vehicles **HAVE** a wire harness that connects to a transmission temperature sensor.

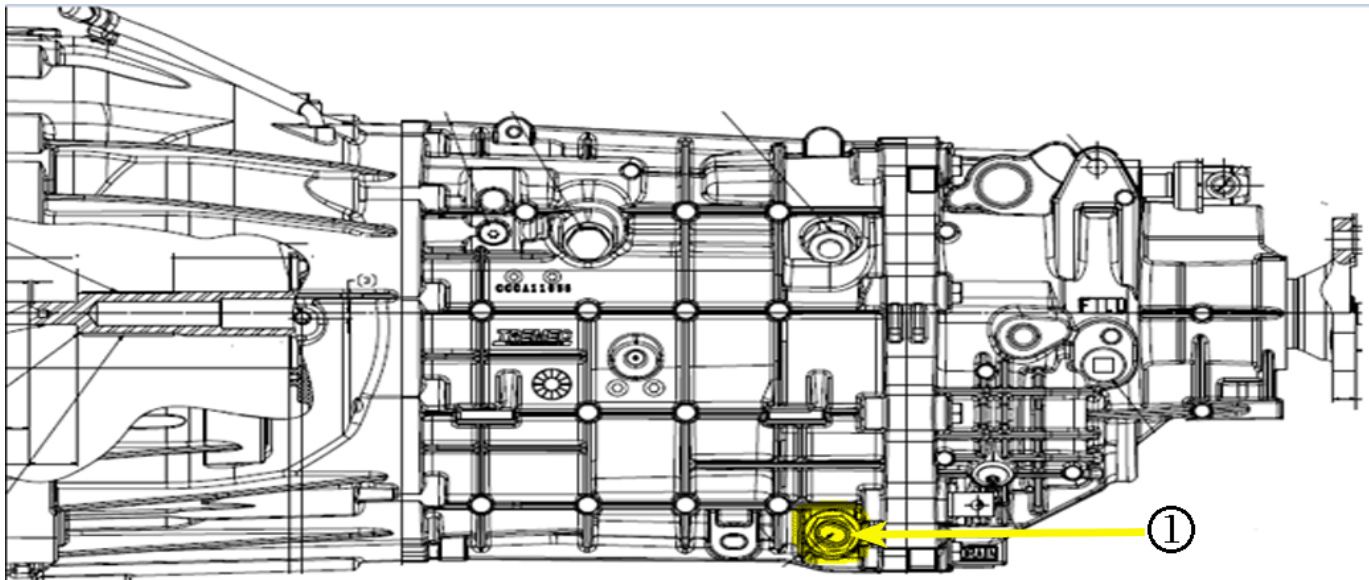

4574137

Transmission cases should be ordered based on the design level of the transmission in combination with model year. As a precaution the part being removed from the vehicle can be inspected to see if it already contains a temperature sensor (1), as shown in the illustration above.

- 24285679 - CASE ASM-TRANS (WITH OUT Temp Sensor) (MY 2013-15 with 2nd Design shift system)
- 24283188 - CASE ASM-TRANS (WITH Temp Sensor) (MY 2016 with 2nd Design shift system)

Version	3
Modified	June 30, 2016 – Revising to include transmission assembly part numbers 24261584 and 24261585. August 23, 2016 – Revising to add 2nd Design Export Parts found in 2013–2015 Catalog and Main Case Part Clarification sections.

