



## Third Row Seat Installation

<b>Classification</b>	Parts and Accessories Bulletin	<b>Section/Group</b>	13 - Seats	<b>Country/Region</b>	North America, Europe, Japan
<b>Year</b>	All	<b>Model</b>	Model S	<b>Version</b>	All

**Bulletin Classification:** *This bulletin provides instructions and guidelines for a vehicle procedure that is not the result of a defect. This bulletin might not be VIN-specific. These instructions assume knowledge of motor vehicle and high voltage electrical component repairs, and should only be executed by trained professionals. Tesla Motors assumes no liability for injury or property damage due to a failure to properly follow these instructions or repairs attempted by unqualified individuals.*

*This Service Bulletin supersedes SB-13-13-001 R5, dated 16-Feb-16. Each content change is marked by a vertical line in the left margin. Discard the previous version and replace it with this one.*

This Service Bulletin contains installation instructions for the optional third row seat. Included in this procedure are steps to add the rear crossmember (if needed), remove and modify existing trim panels, install hardware, add the 2<sup>nd</sup> row seatback bezel, and adjust the latch assembly.

**NOTE:** This procedure can be performed on any vehicle that is eligible for a third row seat based on the information in the “Third Row Seat Eligibility”, “Rear Bumper Plate Inspection”, and “Affected VIN(s)” sections of this document. As with other Service Bulletins, this procedure may be performed by professional 3rd-party repairers. Consequently, there are and can be no restrictions on sales of third row seats to professional 3rd-party repairers.

### Third Row Seat Eligibility

**⚠ WARNING:** Before performing this procedure, confirm that the vehicle is eligible for third row seats. Do not attempt to install third row seats on a vehicle that is not configured to receive third row seats.

- Approximately 50 F and R series vehicles must receive a rear bumper plate update and crossmember retrofit before third row seat installation. While the standard configuration vehicles meet all Federal safety standards, Tesla has increased rear collision protection in vehicles with third row rear-facing seating. Refer to SB-13-10-003, “Rear Bumper Update and Crossmember Retrofit” for the instructions and the affected VIN range.
- 20 vehicles built in November 2012 are unable to be retrofitted for third row seats. Check the “Affected VIN(s)” section of this document for VINs that are not configured to receive third row seats. Do not attempt to retrofit third row seats on these vehicles.
- Third row seats cannot be installed on vehicles with 2<sup>nd</sup> row Executive Seating.
- Unless a vehicle has Executive seating or is called out in one of the two ranges of affected VINs, it is eligible for third row seats. However, after February 14, 2013, the rear crossmember was not installed in any vehicle that was not explicitly ordered with third row seats. These vehicles must receive a rear crossmember retrofit before third row seat installation, as described in the “Rear Crossmember Installation” section of this document.

Correction Description	Correction	Time
Installation of Third Row Seat, Using Template to Cut Panels; Crossmember Installation Not Required	S011313001	1.60
Installation of Third Row Seat, All Trim Panels Already Perforated; Crossmember Installation Not Required	S021313001	1.25
Installation of Crossmember and Third Row Seat, Using Template to Cut Panels	S031313001	1.70
Installation of Crossmember and Third Row Seat, All Trim Panels Already Perforated	S041313001	1.35
Inspection Only; Cannot Install Third Row Seat	S051313001	0.10

Required Part(s):	Part Number	Description	Quantity
	1017509-00-E	*ASY- THIRD ROW SEAT	1
	1022581-00-E	*EU - ASY - THIRD ROW SEAT	1
	1022762-00-E	*CA - ASY - THIRD ROW SEAT	1
	1038318-00-A	*JP - ASY - THIRD ROW SEAT	1
	1013634-00-B	HRST LATCH COVER	1
	1013254-00-A	SCR,M4-1.46X10,PT,TRX,WSHR,ZnBlue	3
	1014747-00-A	BLT,TRX,PFLG,M8-1.25xTBD[9.8]-09	4
	1022449-00-A	BLT,BFLG,TRX,M10x28.4[10.9]-SM-NP-08	2
	2006869-00-A	BARREL NUT, M10	2
	1013633-00-A	2ND ROW BEZEL UPR	1
	1014277-00-A	2ND ROW BEZEL LWR	1
	1009399-00-A	PUSH PIN, STRUT COVER	2
		<b>If the vehicle has the 1<sup>st</sup> generation rear node:</b>	
	1013626-00-B	ASY - HIP STRIKER LH	1
	1013629-00-B	ASY - HIP STRIKER RH	1
		<b>If the vehicle has the 2<sup>nd</sup> generation rear node:</b>	
	1013626-00-D	ASY - HIP STRIKER LH	1
	1013629-00-D	ASY - HIP STRIKER RH	1
		<b>If necessary:</b>	
	1016334-00-A	**ASY, C-PILLAR REAR LH	1
	1016335-00-A	**ASY, C-PILLAR REAR LH, 3RD ROW SEAT	1
	1008173-00-A	**SWITCH, LIFTGATE, 3RD ROW, BASE	1
	6008902-00-A	**PWR LIFTGATE SWITCH, 3RD ROW SEATS	1
	1015811-S0-B	REAR CROSSMEMBER SVC	1
	1006883-00-A	NUT HF M10x1.5 ZnAl [10]	8

\*NOTE: Order ASY-THIRD ROW SEAT by specific region (USA, EU, Canada, or Japan)

\*\*NOTE: Order C-Pillar Rear LH and switch by liftgate style

**Shop supplies:**

Super Glue (1031098-00-A\* or equivalent)

\*Available on the Tesla Chemicals website.

These part numbers were current at the time of publication. Use the revisions listed or later, unless otherwise specified in the Parts Manual.

Special Tool(s):	If necessary:
	1023385-01-A THIRD ROW SEAT TEMPLATE

## Rear Trim Panel Removal

1. Remove the rear trunk load floor.
2. Remove the screw that secures the RH C-pillar rear trim panel. Unfasten the trim clips and remove the panel.
3. Remove the screw that secures the LH C-pillar rear trim panel (Figure 1). Carefully unclip and remove the panel enough to see the liftgate switch wiring harness connector. Release the connector by hand.

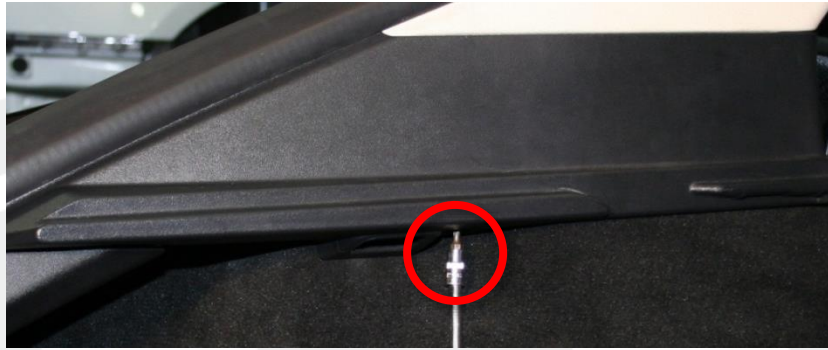


Figure 1

**NOTE:** If the vehicle does not already have an interior liftgate switch, replace the LH C-pillar rear trim panel with a version that has an access hole for a switch. The appropriate switch for the power or manual liftgate must also be installed when the vehicle is reassembled. See the Affected Parts list for part numbers, and bulletin SB-13-17-004, “Interior Liftgate Switch Verification”, for instructions.

4. Disengage the four trim clips that secure the trunk sill panel and remove it (Figure 2).



Figure 2

5. Remove the LH and RH trunk side trim panel covers (Figure 3).

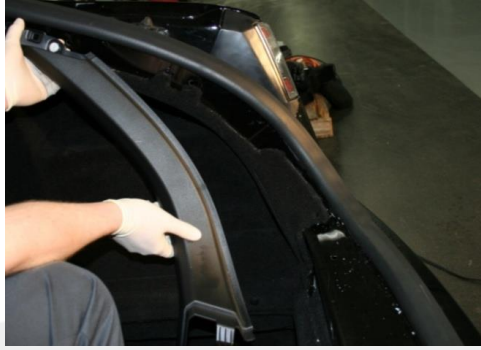


Figure 3 (RH shown, LH similar)

## Trunk Carpet Trim Removal

1. Remove the retaining finisher buttons and fir tree clips around the top of the footwell (Figure 4).

**NOTE:** Some parts might have Velcro strips instead of finisher buttons.

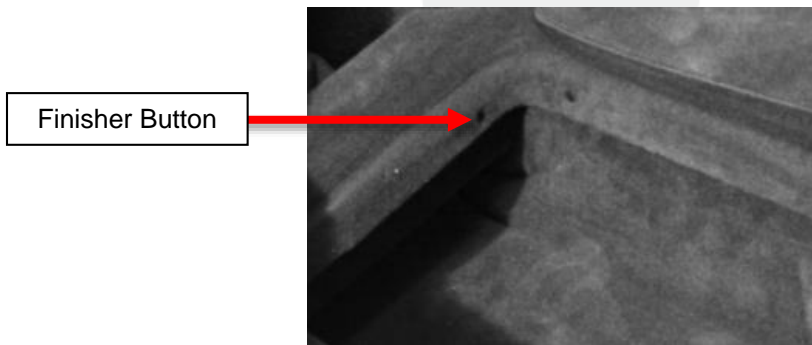


Figure 4

2. Remove the clips on the outboard edge of the lower carpet to release it from the trunk floor trim carpet.
3. Remove the 3 fir tree clips that secure the back edge of the trunk floor trim carpet along the seats: one at each corner and one at the 60/40 seat split.
4. Pull upward on the trunk floor trim carpet to remove it (Figure 5) and set it aside on a protective surface.

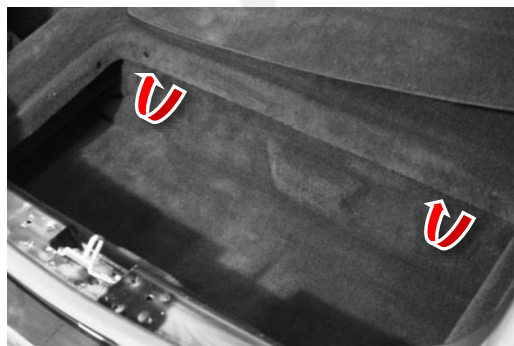


Figure 5

5. Remove the trunk footwell carpet and set it aside on a protective surface.
6. Remove the LH and RH strut cover (side rail cover) rear carpets and set them aside on a protective surface.
7. Remove the 2 fir tree clips at the front and back corners of the LH trunk side trim panel.
8. Carefully pull back the liftgate edge of the panel. If the trim has trunk lights, disconnect the trunk light wiring harness by pressing the tab (Figure 6).



**Figure 6**

9. Remove the LH trunk side trim carpet panel and set it aside on a protective surface.
10. Repeat steps 6-8 to remove the RH trunk side trim panel.

## Rear Bumper Plate Inspection

1. Hold the trunk floor insulation away from the rear body panel.
2. Look down the outboard side of the side rails where they meet the rear bumper plate. Verify that:
  - 4 bolts connect the tabs of the rear bumper plate to the side rail (Figure 7).
  - 4 visible studs run through the rear panel to protrude under the fascia. The stud heads are visible through the bumper plate. The top and bottom are for the rear bumper, and the middle two are for the rear crossmember.

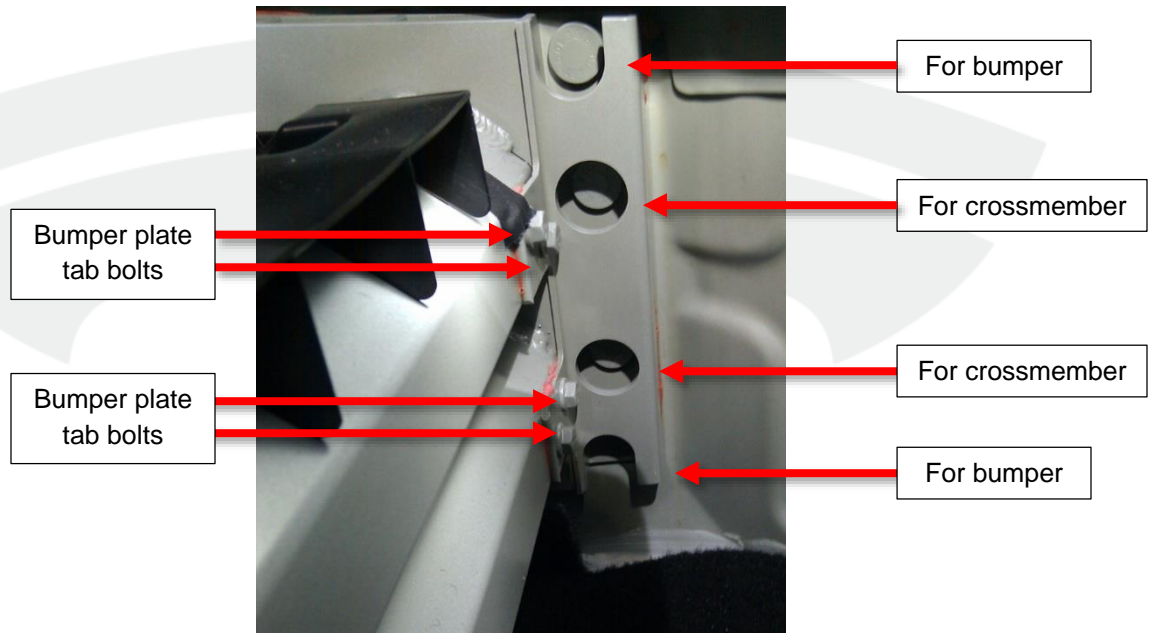


Figure 7 (LH pictured, RH similar)

Some early cars might have an L-bracket with tabs installed, which is also acceptable (Figure 8).



Figure 8



**⚠ WARNING:** If the vehicle is missing either the 8 crossmember studs or the rear bumper plates with bolted tabs, this vehicle cannot be retrofitted with third row seats. Reinstall the trunk carpets and trunk trim.

3. If the car has rear bumper plate tabs and has 8 studs per side (4 bumper, 4 crossmember), continue with “Rear Crossmember Installation”.

## Rear Crossmember Installation

1. Remove the rear fascia assembly (refer to Service Manual procedure 10013001).
2. Remove the 8 flange nuts that secure the rear bumper (Figure 9). Remove the bumper from the vehicle.



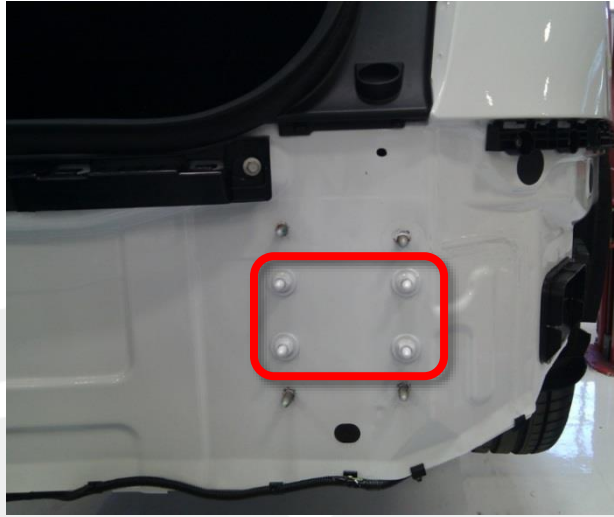
**Figure 9 (Rear bumper highlighted)**

3. Check whether a rear crossmember is already installed (Figure 10). If a rear crossmember is already installed on its 8 studs, reinstall the bumper (torque 52 Nm) and rear fascia and skip directly to the “Template Preparation” section.



**Figure 10 (Rear crossmember installed)**

4. If a rear crossmember is not yet installed, but 8 studs exist on the rear panel next to the bumper studs (Figure 11), remove the flange nuts and any washers from the studs. Discard any washers that were installed on the vehicle.



**Figure 11 (Rear crossmember studs)**

5. Install the rear crossmember onto the vehicle using 4 M10 flange nuts on each end (torque 50 Nm).
6. Reinstall the rear bumper on the vehicle using the original flange nuts (torque 52 Nm).
7. Reinstall the rear fascia assembly.



## Template Preparation

This template consists of a kit that has total of 5 templates and is available to modify carpet and plastic trim if the trim pieces are not already perforated (Figures 12 and 13):

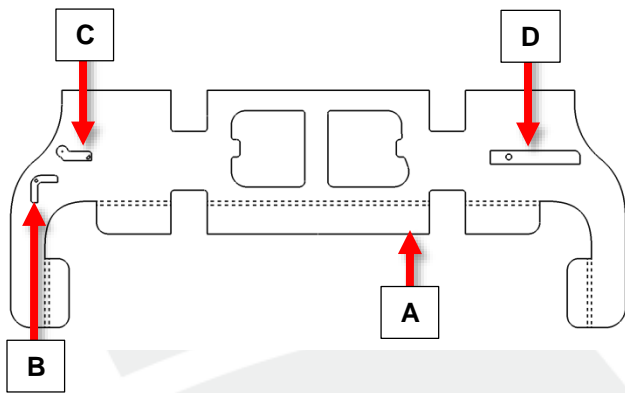


Figure 12

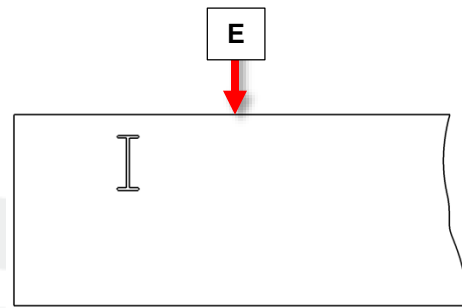


Figure 13

Description	Application
Template A	Main template for cutting the trunk floorboard and footwell carpet
Template B	Properly bending template A along the perforated lines
Template C	Drilling a hole in the LH and RH side plastic strut covers
Template D	Cutting the strut cover carpet (side rail cover)
Template E	Cutting the LH and RH side carpet trim panels

**NOTE:** Check the procedures ahead to verify whether any of these templates are required. If so, assemble the templates as shown.

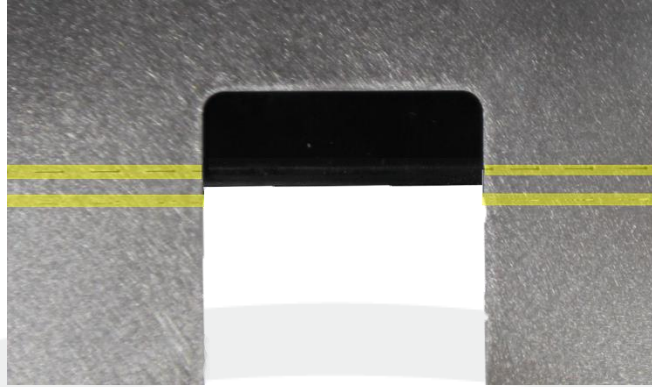
**NOTE:** This procedure only needs to be performed before the template is used for the first time.

**⚠ WARNING:** Take care when preparing the template. The edges might be sharp. Wear nitrile coated gloves for protection when handling the template.

1. Inspect template sections (Figures 12 and 13).
2. Place the main template A on the edge of a workbench.

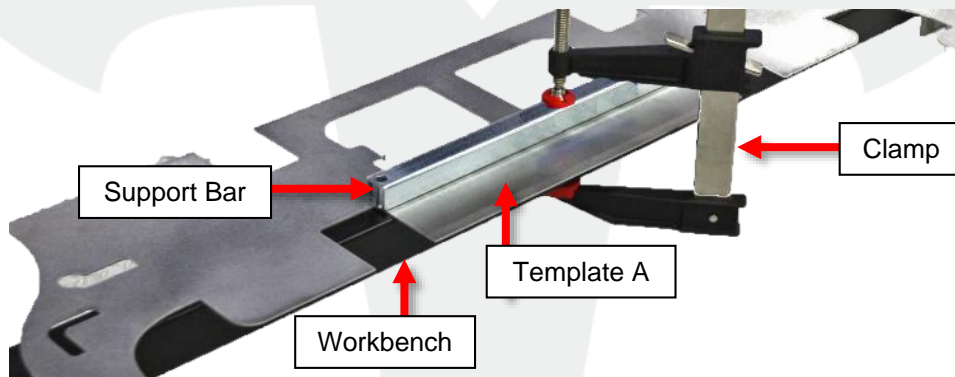
**TIP:** Use a workbench with a ¼" radius edge for better results.

- Align the edge of the workbench between the template marking lines (Figure 14).



**Figure 14 (Template marking lines highlighted)**

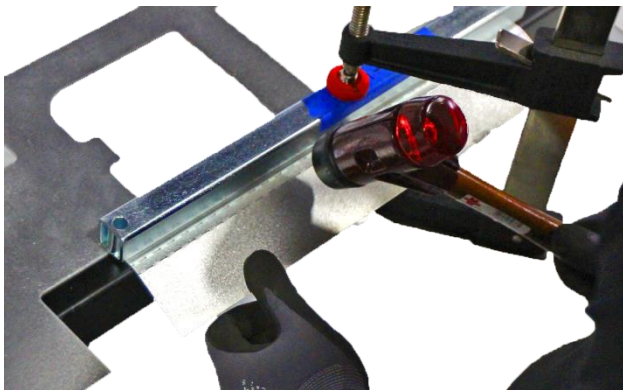
- Put a support bar on top of the template, then secure the template with a clamp (Figure 15).



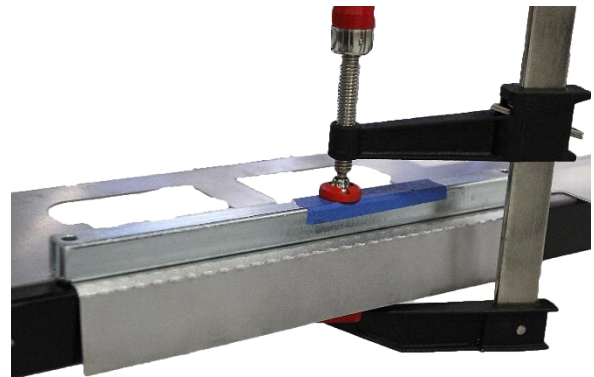
**Figure 15**

**⚠ CAUTION:** Do not bend the template past 90 degrees to avoid breaking the template.

- On template A, use a deadblow hammer to bend the tabs at the perforated lines (Figure 16) from straight to approximately a 90 degree angle (Figure 17).



**Figure 16**



**Figure 17**

- Verify the bent angles on template A with template B (Figures 18 and 19). Move template B along the bent tabs on template A, adjusting the tabs as needed to close any gaps between the two templates.

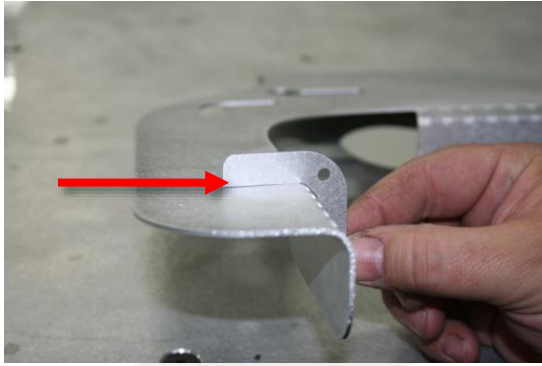


Figure 18

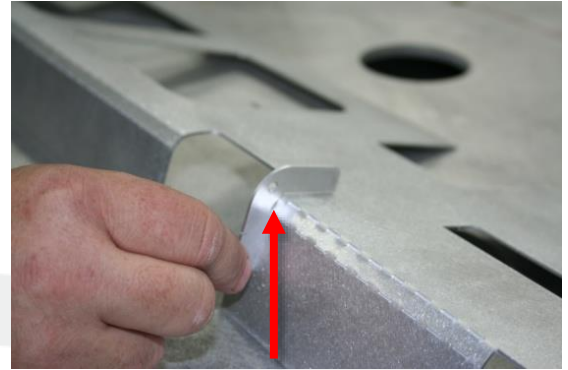


Figure 19

## Side Carpet Trim Panel Modification

**NOTE:** Some vehicles already have perforations in the side carpet trim panels. Check for perforations in the panels, using template E as a guide. If perforations already exist, proceed to step 3. Template E is used for both the LH and RH side carpet trim panels. Invert the template for each side (Figure 20).



Figure 20

- Align the template E along the backside lower rear corner of the side carpet trim panel. Align the curved side of template with the rear edge of the trim panel. Trace the slot opening with a marker pen (Figure 21).

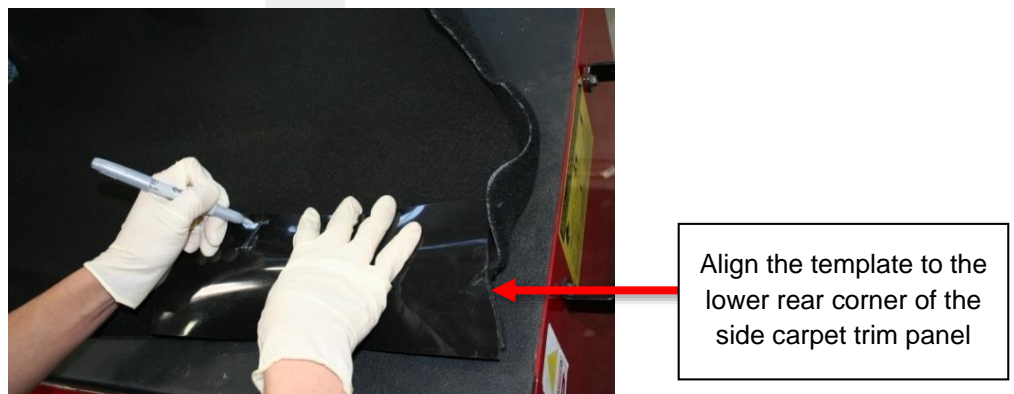


Figure 21

2. Mark a center hole for the drill bit at the two line intersections, and then connect the dots (Figure 22).



Figure 22

3. Drill a 13 mm diameter hole at each of the two marked center intersection dots, and then cut a slit connecting the two holes (Figures 23 and 24).



Figure 23



Figure 24

## Plastic Strut Cover Modification

1. Place template C on the inboard edge of the LH plastic strut cover. The flat edge of the template with the indicator slot faces toward the back of the vehicle. The round edge of the template faces toward the front of the vehicle.
2. Mark a drill hole with a center punch as indicated by template C (Figure 25).

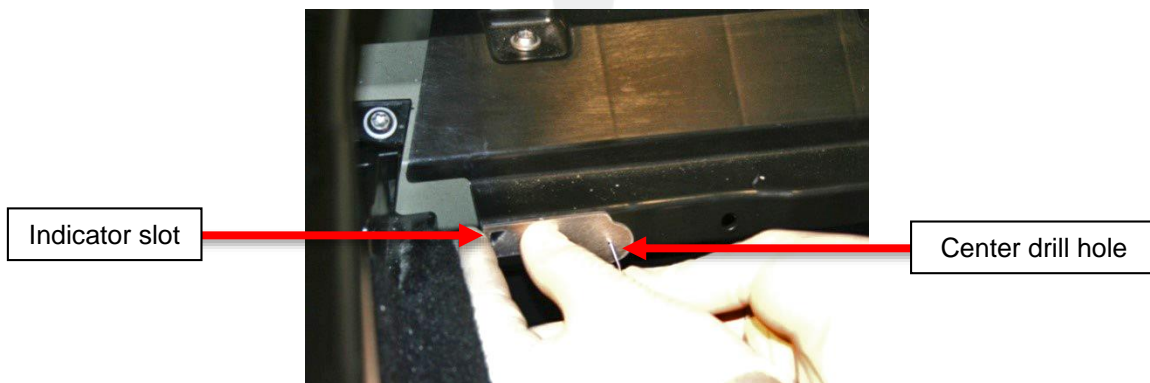


Figure 25 (LH shown, RH similar)

3. At the hole mark, drill a 5 mm diameter hole in the LH plastic strut cover (Figure 26).



**Figure 26 (LH shown, RH similar)**

**NOTE:** Invert the template for use on the RH plastic strut cover.

4. Repeat steps 1–3 for the modification of the RH plastic strut cover.

## **Strut Cover Carpet Modification**

**NOTE:** Identify the part of the strut cover carpet that needs to be removed. This step adds extra clearance for the third row seat assembly as it folds into and exits the footwell (Figure 27).



**Figure 27**



1. Place template D on the back side of the footwell carpet (Figure 28). The round hole in template D aligns with the hole in the carpet. Place a pen or similar object in the template alignment hole to hold it place.



**Figure 28**

2. Trace along the outside perimeter of template D with a paint pen or marker (Figure 29).



**Figure 29**

3. Cut the carpet section around the marked outline (Figure 30).



**Figure 30**



- Place the LH and RH carpeted strut covers in position (Figures 31 and 32).



**Figure 31 (LH carpet)**



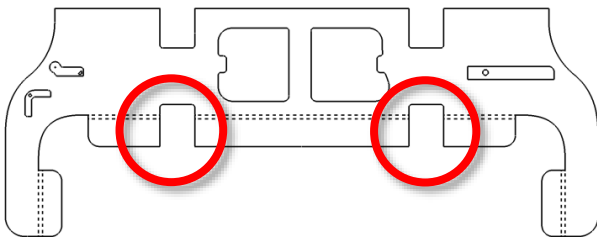
**Figure 32 (RH carpet)**

- Install fir tree push pins to secure the carpet on the LH and RH sides.
- On each side of the vehicle, install a fir tree push pin to fasten the carpeted strut cover to the hole that was drilled in the "Plastic Strut Cover Modification" section.

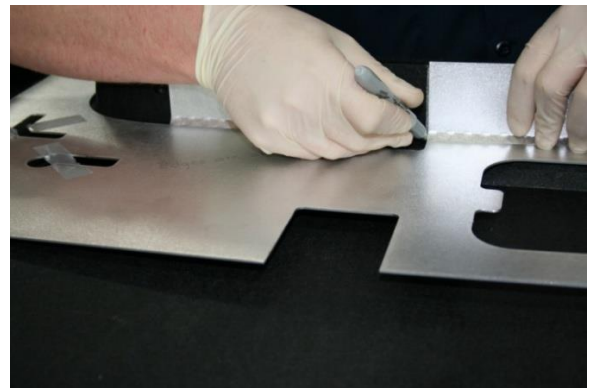
## Trunk Floorboard Carpet Modification

**NOTE:** Some vehicles already have perforations in the trunk floor carpet. Check for perforations in the carpet, using template A as a guide. If they already exist, proceed to step 2.

- Align template A against the back of the trunk floorboard carpet. Use a marker pen to mark the outline of the LH and RH trunk floorboard carpet third row seat mounting access holes (Figures 33 and 34).



**Figure 33**



**Figure 34**

2. Remove the carpet sections with a cutting tool along the marked lines (Figure 35).

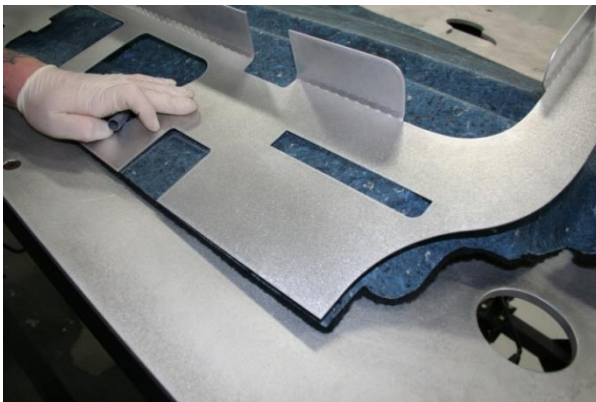


**Figure 35**

## Footwell Carpet Modification

**NOTE:** Some vehicles already have perforations in the footwell carpet. Check for perforations in the carpet, using template A as a guide. If they already exist, proceed to step 2.

1. Align template A against flat edge of the footwell carpet to locate the third row seat mounting bracket access holes. Mark the holes with a paint pen or marker (Figures 36 and 37).



**Figure 36**



**Figure 37**

2. Remove the carpet sections for the LH and RH mounting bracket holes with a cutting tool.

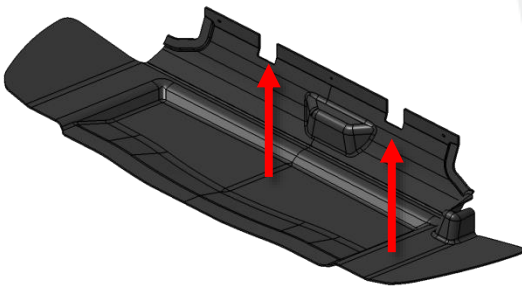
## Insulation Pad Modification

1. Inspect the insulation pad for pre-existing perforations (Figure 38). If perforations are visible, proceed to step 5.

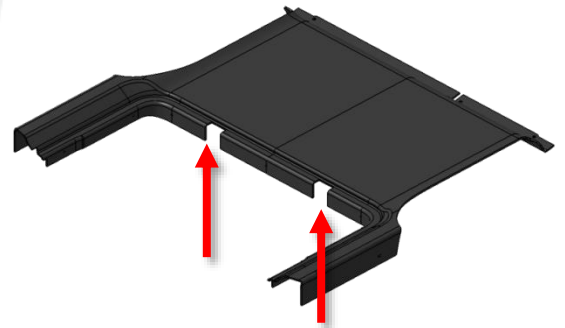


**Figure 38**

2. If perforations are not visible, temporarily install the footwell and trunk floor carpet sections to use as a template (Figures 39 and 40).



**Figure 39 (Footwell carpet)**



**Figure 40 (Trunk floor carpet)**

3. Using the cutouts in the carpet as a template, mark the location of the knee pivot third row seat mounting bracket openings with a paint marker (Figures 41 and 42).



**Figure 41**



**Figure 42**

4. Remove the footwell carpet and trunk floor carpet.
5. Cut the insulation pad along the existing perforations or along the perimeter of the marked area (Figures 43 and 44).



Figure 43



Figure 44

## Knee Pivot Mounting Bracket Hardware Installation

1. Screw a few threads of the mounting bracket bolt into the nut insert with the flat side facing out.
2. Place the nut insert in the back of the body panel into the retaining rails (Figure 45).

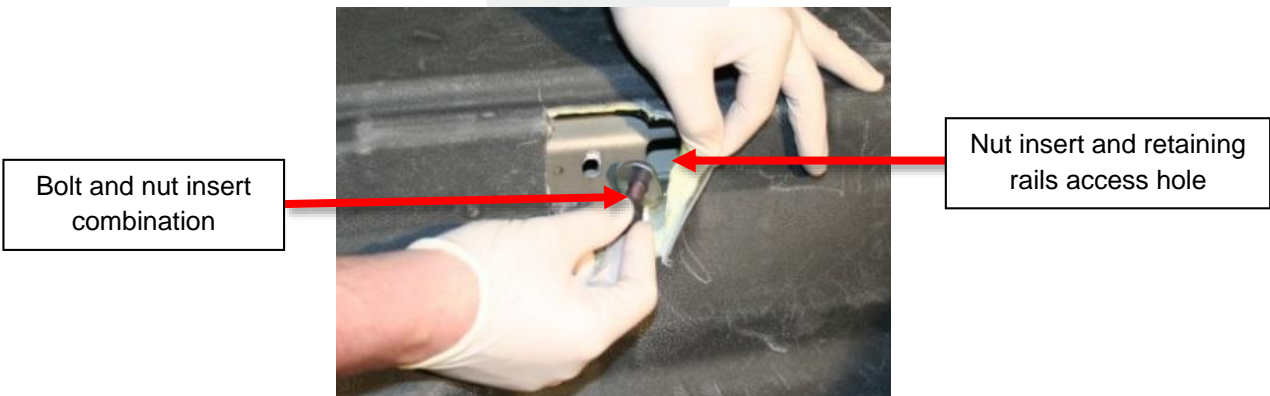


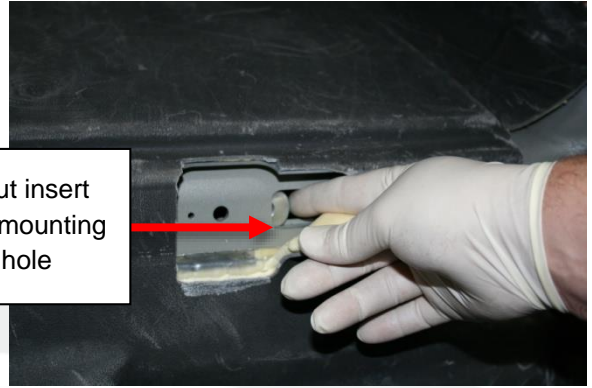
Figure 45 (RH shown, LH similar)



3. Unscrew the bolt and slide the nut insert within the holding rail towards the mounting bracket hole until the threads are visible (Figures 46 and 47).



**Figure 46 (RH shown, LH similar)**



Slide nut insert  
towards mounting  
bolt hole

**Figure 47 (RH show, LH similar)**

4. Hold the nut insert in place and start threading the bolt for a few threads to retain (Figure 48).



**Figure 48**

5. Repeat this procedure for the LH mounting bracket hole.

## Side Striker Wire Installation

1. Inspect the LH and RH striker insulation pad for pre-existing perforations (Figure 49). If perforations are visible, proceed to step 4.



**Figure 49**

2. If perforations are not visible, locate the top and bottom striker mounting bolt holes with your hand. Press the area under the insulation pad, feeling for the raised threaded mounting boss. Cut out the insulation section around this area.
3. Remove this insulation section to expose the lower mounting bolt threads (Figures 50 and 51). Temporarily place the striker with the long end up to locate the upper mounting bolt boss. Mark and cut the insulation pad to expose the top threaded boss.



**Figure 50**



**Figure 51**

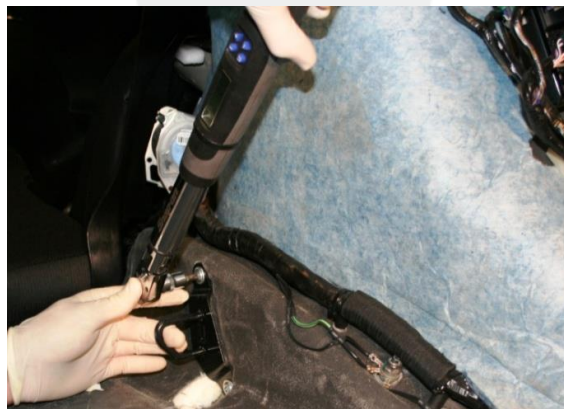


4. Ensure the long end of the striker wire faces upward. Mount the striker flush with the body panel and evenly hand tighten the upper and lower striker mounting bolts (Figure 52).



**Figure 52**

5. Repeat steps 1–4 for the RH striker installation.
6. Torque the LH and RH striker bolts to 16.5 Nm (Figure 53).



**Figure 53**

## Second Row Seat Back Modification

**NOTE:** The sections of upholstery and carpet that are cut as part of this procedure will be covered by a trim bezel.

1. Press down on the center of the 2<sup>nd</sup> row seat back along the carpet and upholstery seam to locate the hidden seat latch. (Figure 54). The latch can be felt as two cavities under the carpet and upholstery.



**Figure 54**

2. Trace the latch cavities with chalk as a guideline if needed.
3. Cut the carpet and upholstery around the two indentations to expose the latch components (Figure 55).



**Figure 55**

4. The vertical length is approximately 55 mm and the horizontal total length is about 120 mm (Figures 56 and 57).

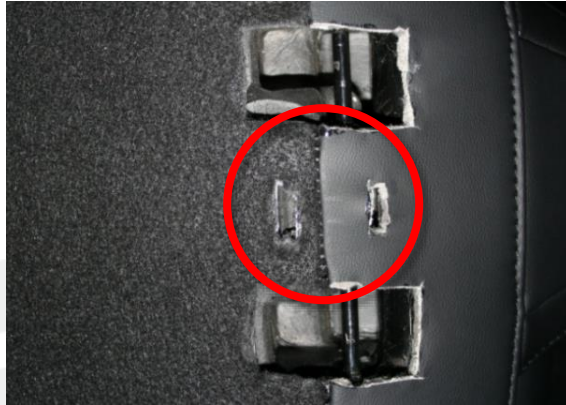


**Figure 56 (Vertical)**



**Figure 57 (Horizontal)**

5. Press down and feel for two horizontal cavities approximately 20 mm in length at the center of the seat back.
6. Cut out the 20 mm cavities, one in the carpet section and one in the upholstery (Figure 58).



**Figure 58**

7. To ensure fabric integrity and prevent fraying, apply a few drops of super glue to the exposed fabric threads where the carpet and seat cover meet at the four areas (Figure 59).



**Figure 59**

8. Install the two center attachment trim clips in the back of the 2<sup>nd</sup> row seat bezel (Figure 60).



**Figure 60**

9. Install the lower half (the carpet side) of the finisher bezel to the seat back.

**NOTE:** The lower bezel is smaller than the upper bezel.

10. Install the upper half (upholstery side) of the finisher bezel to the seat back (Figure 61). Ensure that the bezel fits against the seat back frame and snaps onto the strikers. The two center trim clips secure the bezel to the seat frame.



**Figure 61**

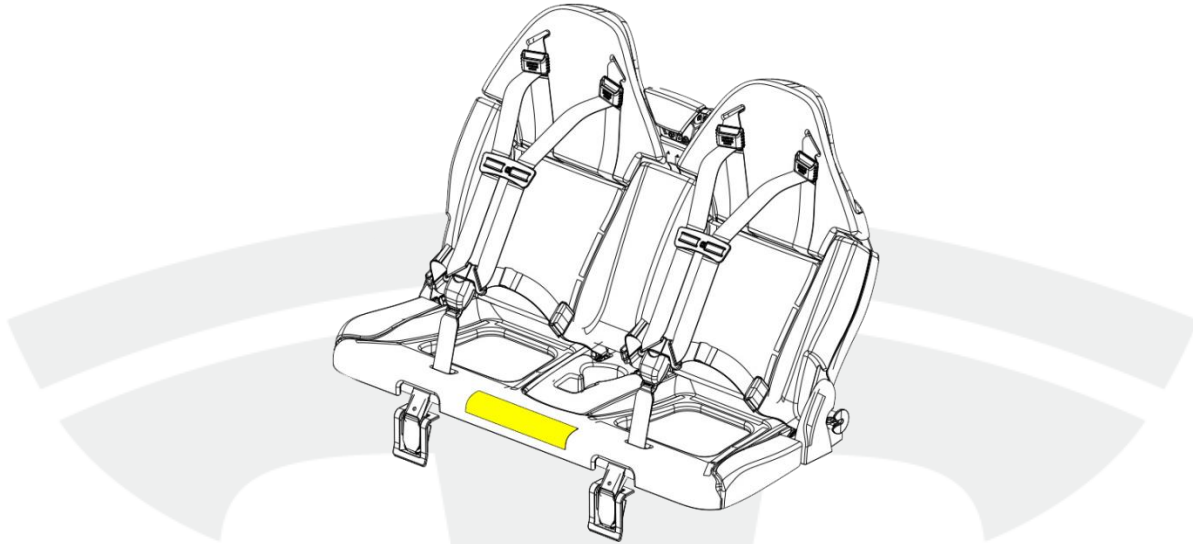
## Carpet and Trim Installation

1. Install the trunk side trim panel covers.
2. Install the rear footwell carpet.
3. Install the trunk floor carpet.
4. Install the LH and RH side trim panels. Ensure that the left and right trunk lights are connected before fastening fir tree clips.
5. Install the rear trunk sill panels.
6. Install the LH and RH liftgate carrier sill panels.

**NOTE:** Ensure that the correct rear liftgate switch is installed in the LH trunk sill panel, depending on whether the vehicle has a power or manual liftgate.

## Third Row Seat Assembly Installation

1. Inspect the regulatory label on the front of the third row seat assembly (Figure 62) and ensure that it is the correct seat for the vehicle's region. Do not install the seat if it has the incorrect regulatory label.



**Figure 62 (Regulatory label highlighted)**

2. With an assistant, place the seat in position in the rear trunk area (Figure 63).

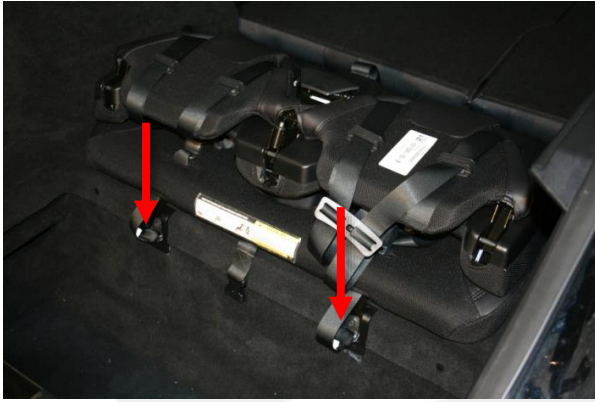


**Figure 63**

3. Remove the mounting bracket retaining bolts that are holding the nut inserts in place.
4. Verify that the third row seat mounting bracket holes are aligned with the threaded nut inserts behind the body panel.
5. Thread and hand tighten the third row seat LH and RH mounting bracket bolts.



6. Ensure that the third row seat mounting brackets are flush with the body panel. If the insulation prevents the mount from sitting flush, trim the excess insulation or carpet as necessary (Figures 64 and 65).



**Figure 64**



**Figure 65**

7. Insert the LH and RH mounting bolts through the seat belt loops.
8. Pull the seat belts aside and tighten the LH and RH mounting bolts (torque 26 Nm). Ensure that the seat belt loops are facing down when fastening the mounting bolts.
9. Raise the 2<sup>nd</sup> row seat to the normal upright position.
10. Unfold and latch the third row seat headrest. Lift the third row seatback towards the 2nd row seat. While lifting, ensure the side latches are engaging correctly into both left and right side strikers (Figures 66 and 67).



**Figure 66 (Correct alignment)**



**Figure 67 (Incorrect alignment)**

**NOTE:** If the latches are aligned too high, the trunk floor carpet is keeping the seat from sitting in the proper position. Kneel on both sides of the seat cushion, using your body weight to compress the seat and carpet. The carpet should stay compressed, keeping the hooks in proper alignment permanently.



## Seat Latch Alignment

1. Remove the latch surround trim piece from the third row seat.
2. Secure the third row upper latch to the second row seat. The latch assembly comes with the nuts slightly loose, and self-aligns to the 2<sup>nd</sup> row seat striker (Figure 68).



**Figure 68**

3. With the third row seatback still latched to the 2<sup>nd</sup> row seat, tighten the 4 latch nuts (torque 5.0 Nm) (Figure 69).



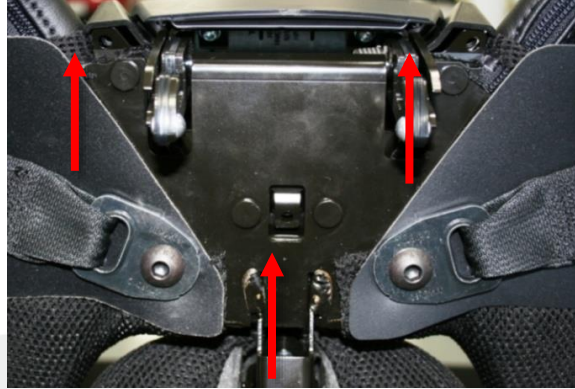
**Figure 69**

4. Unlatch the third row seat. Reinstall the latch surround trim (Figure 70).



**Figure 70**

- Secure the latch surround trim with the 3 screws (torque 0.5 Nm) (Figure 71).



**Figure 71**

- Verify proper latching of the third row seat to the 2<sup>nd</sup> row seat back for smooth engaging and release.
- Unlatch and fold the third row seat into the footwell to check for proper fit. Verify for unobstructed movement of the third row seat assembly entering and exiting the footwell area.

## Update Vehicle Configuration

- Use Toolbox to change the “Rear Facing Seats” configuration variable to **Base**.

**Affected VIN(s)** This information is for reference purposes only. This list is not intended to be the sole information source for updates.

**⚠ WARNING:** Third row seats in any vehicle built after February 14, 2013 require installation of the bolt-on rear crossmember. Earlier VINs must be checked to verify the presence of a crossmember.

**⚠ WARNING:** Do NOT install third row seats in the following VINs:

5YJSA1DP4CFS01070	5YJSA1DP8CFP01362	5YJSA1DN2CFP01677
5YJSA1DP1CFS01074	5YJSA1CPXCFP01364	5YJSA1DP6CFP01697
5YJSA1DP5CFS01076	5YJSA1DP3CFP01365	5YJSA1CN8CFP01703
5YJSA1DP7CFS01080	5YJSA1DP6CFS01085	5YJSA1DN5CFP01706
5YJSA1DP2CFS01083	5YJSA1DP3CFP01639	5YJSA1DN7CFP01724
5YJSA1DP2CFP01356	5YJSA1DP5CFP01643	5YJSA1CN0CFP01727
5YJSA1CP6CFP01359	5YJSA1CN0CFP01663	

For feedback on the accuracy of this document, email [ServiceBulletinFeedback@tesla.com](mailto:ServiceBulletinFeedback@tesla.com).