



# Service Bulletin

File in Section: -

Bulletin No.: 16-NA-060

Date: May, 2016

## TECHNICAL

**Subject:** Difficulty Shifting Out of Park or into Park

Brand:	Model:	Model Year:		VIN:		Engine:	Transmission:
		from	to	from	to		
Chevrolet	Malibu (VIN Z)	2016	2016				
	Volt	2016	2017				

<b>Involved Region or Country</b>	NORTH AMERICA (All), ISRAEL (Malibu), KOREA (Volt)
<b>Condition</b>	Some customers may comment that it is difficult to move the shifter out of Park or into Park.

### Correction

Do not immediately replace any parts until the transmission control lever knob assembly has been validated to be fully installed onto the shifter and operating correctly.

Follow the Service Procedure steps in order to verify operation and properly repair.

### Service Procedure

#### First Check

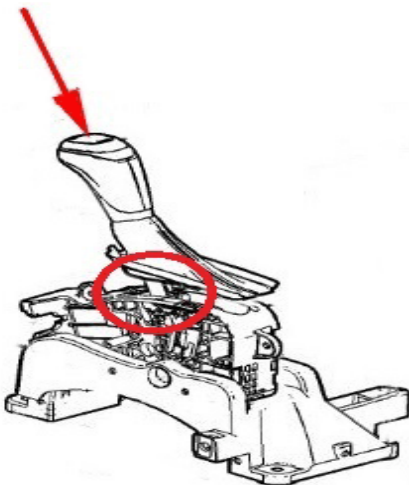

4421604

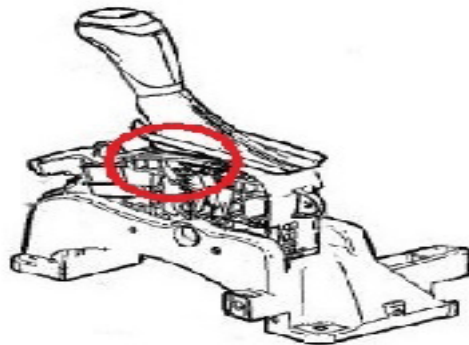

4421606

- If movement was confirmed and the knob is fully seated onto the shifter, verify the shifter assembly moves freely.
- If this does not correct the concern, proceed to the following Second Check for further diagnostics.

#### Second Check

Check the shift cable for adjustments.

- If the cable was confirmed out of adjustment, correct if necessary. Refer to *Shift Cable Adjustment* in SI.
- If this does not correct the concern, proceed to the following Third Check for further diagnostics.

While pressing downwards on the knob firmly with both hands, validate any movement felt and the bottoming out of the knob to shifter.

**Third Check**

With the shift knob boot pulled up, check for possible intermittent binding of the Brake Transmission Shift Interlock (BTSI) solenoid plunger within the shifter assembly by applying and releasing the brake pedal. It will likely require 3-6 consecutive brake pedal applies to duplicate the concern or verify proper operation.

- if any delay in BTSI release is observed, replace the shifter assembly. Refer to *Shifter Assembly Replacement* in SI.
- If this does not correct the concern, refer to SI for further diagnostics.

**Parts Information**

Description	Part Number	Qty
CONTROL, A/Trans (W/O Base) (Malibu 6 Speed)	13509999	1
CONTROL, A/Trans (W/O Base) (Malibu 8 Speed)	13510000	1
CONTROL, A/Trans (W/O Base) (Volt)	13509998	1

**Warranty Information**

For vehicles repaired under warranty, use:

Labor Operation	Description	Labor Time
8480208*	Inspect and Verify Transmission Control Lever Knob Installation	0.3 hr
Add	To Adjust the Range Selector Lever Cable	0.5 hr
Add	To Replace the Transmission Control	0.7 hr
*This is a unique Labor Operation for Bulletin use only.		

<b>Version</b>	3
<b>Modified</b>	March 29, 2016 – Adding additional Checks to the Service Procedure section. April 20, 2016 – Added Chevrolet Volt and new part numbers.

