



Service Bulletin

File in Section: -

Bulletin No.: 16-NA-123

Date: July, 2016

TECHNICAL

Subject: Cooling Fan Inoperative, Malfunction Indicator Lamp ON (Check Engine Light), and/or DTC P0480, P0691 Set

Models: 2016 Chevrolet Malibu (VIN Z)

Brand:	Model:	Model Year:		VIN:		Engine:	Transmission:
		from	to	from	to		
Chevrolet	Malibu (VIN Z)	2016	2016			All	All

Involved Region or Country	North America and Israel
Condition	Some customers may comment that the Malfunction Indicator Lamp (MIL) or (Check Engine Light) is ON. Technicians may find DTC P0480 and/or P0691 set.
Cause	Upon inspection, technicians may find water intrusion in the X117 cooling fan connector.

Correction

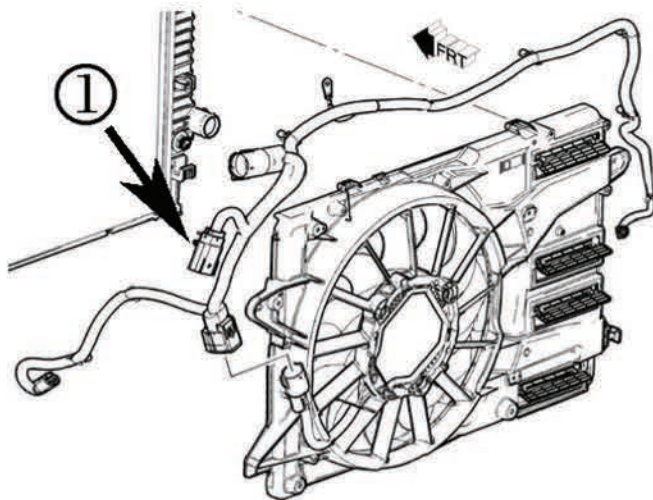

4452764

Cooling fan harness connectors (1) are to be inspected. The harness connector on the engine side is to be cleaned if possible, and the cooling fan jumper harness should be replaced if needed.

Service Procedure



4452766

Inspect the X117 cooling fan connectors for possible corrosion or open cavities. Refer to *X117 Engine Harness to Cooling Harness* in SI. If corrosion is found on the cooling fan harness side, or the connector is found to have unused terminal cavities that are not plugged, replace the cooling fan jumper harness. Refer to *Engine Coolant Fan Wiring Harness Replacement* in SI.

Inspect and clean the connector on the engine harness side.

Parts Information

Refer to the GM Electronic Parts Catalog (EPC) with vehicle identification number (VIN) to determine part information.

Description	Part Number	Qty
HARNES, ENG COOL FAN WRG	Refer to EPC	1

Warranty Information

Labor Operation	Description	Labor Time
4081208*	Engine Coolant Fan Wiring Harness Replacement	2.2 hrs
*This is a unique Labor Operation for Bulletin use only.		

Version	2
Modified	June 17, 2016 – Removed engine RPO restriction. Bulletin now applies to all engines.

