



Technical Journal

TITLE:

Noise from timing belt during idling

REF NO: TJ 31467	ISSUING DEPARTMENT: Technical Service	CAR MARKET: United States and Canada	
PARTNER: 3 US 7510 Volvo Car USA		ISSUE DATE: 2016-04-07	STATUS DATE: 2016-04-12
FUNC GROUP: 2158	FUNC DESC: Tensioner	Page 1 of 7	

“Right first time in Time”

Attachment

File Name	File Size
TJ31467- noise from timingbelt.m4a	0.1201 MB
TJI-494212-1_1_0_en-US.pdf	0.8488 MB

Vehicle Type

Type	Eng	Eng Desc	Sales	Body	Gear	Steer	Model Year	Plant	Chassis range	Struc Week Range
138	40	B4204T11					2016-2016	36	0085122-9999999	201517-203052

CSC Customer Symptom Codes

Code	Description
ZE	Idling/Unusual noise

VST Operation Number

VST Operation Number	Description
98628-2	Camshaft belt adjust

Text

DESCRIPTION:

Noise from the timing belt may occur on new cars when the engine is idling.
Check attached sound file for reference.

**SERVICE:**

Do not replace any parts!

Perform a re-adjusting of the timing belt tension according the attached instruction.

VEHICLE REPORT:

Yes, please submit a Vehicle Report if the service solution described in this TJ has no effect. Use concern area "Vehicle Report" and sub concern area "Support not needed", use function group 2158.

To view TJ attachments continue to next page. This TJ has two attachments.



Volvo Car Customer Service

TJ Instruction VCC-494212-1

Title	Timing belt	Page	1 (5)
Action	Adjustment	Operation number:	98628-2

Issue	Date	Reason
1	2016-04	First issue

Affected vehicles

Model year	Model	Engine
2016	S60L	B4154T4 B4204T11, T19
2016	XC60	B4204T11

Equipment

Designation	Part No.
Allen key	

Removal

Note! Removal steps in this procedure may contain installation details.

Color symbols

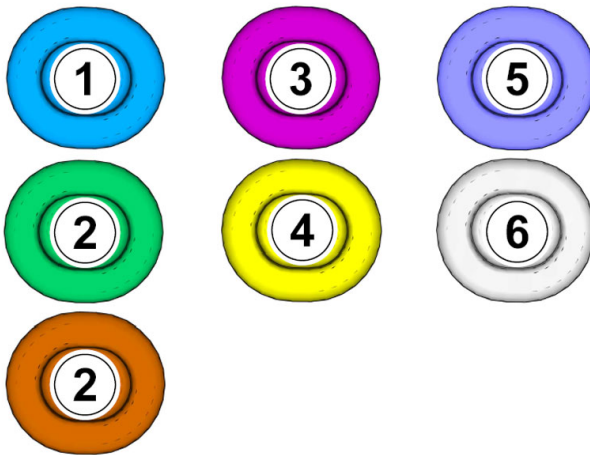

Note! This colour chart displays (in colour print and electronic version) the importance of the different colours used in the images of the method steps.

- 1 . Used for focused component, the component with which you will do something.
- 2 . Used as extra colors when you need to show or differentiate additional parts.
- 3 . Used for attachments that are to be removed/installed. May be screws, clips, connectors, etc.
- 4 . Used when the component is not fully removed from the vehicle but only hung to the side.
- 5 . Used for standard tools and special tools.
- 6 . Used as background color for vehicle components.

Remove the following components:

- Engine support insulator, right , refer to:
Removal, replacement and installation
2 - Engine with mountings and equipment
21 - Engine
218 - engine mounting
- the auxiliaries belt , refer to:
Removal, replacement and installation
2 - Engine with mountings and equipment
21 - Engine
215 - transmission

Remove the screws.

Torque:

M6 , 10 Nm

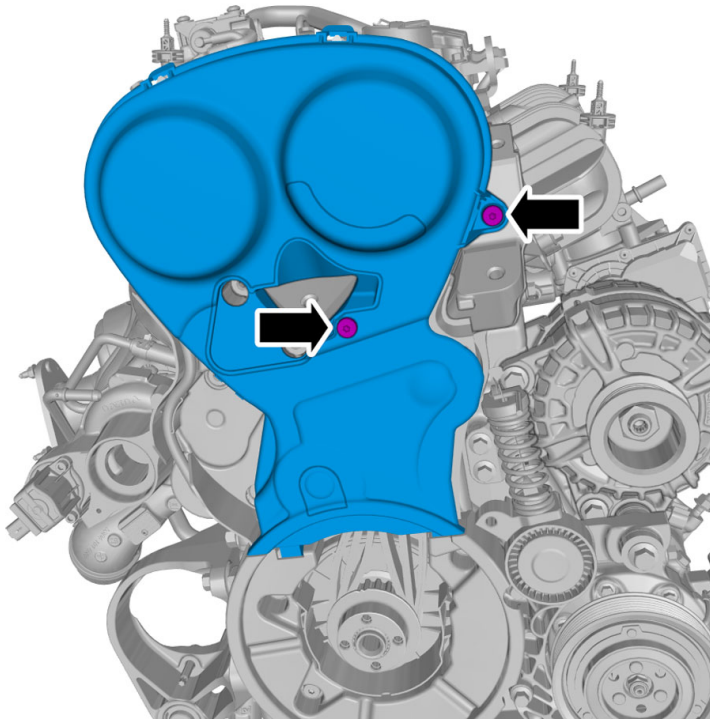

Belt tensioner adjustment

Do not loosen more than one turn.

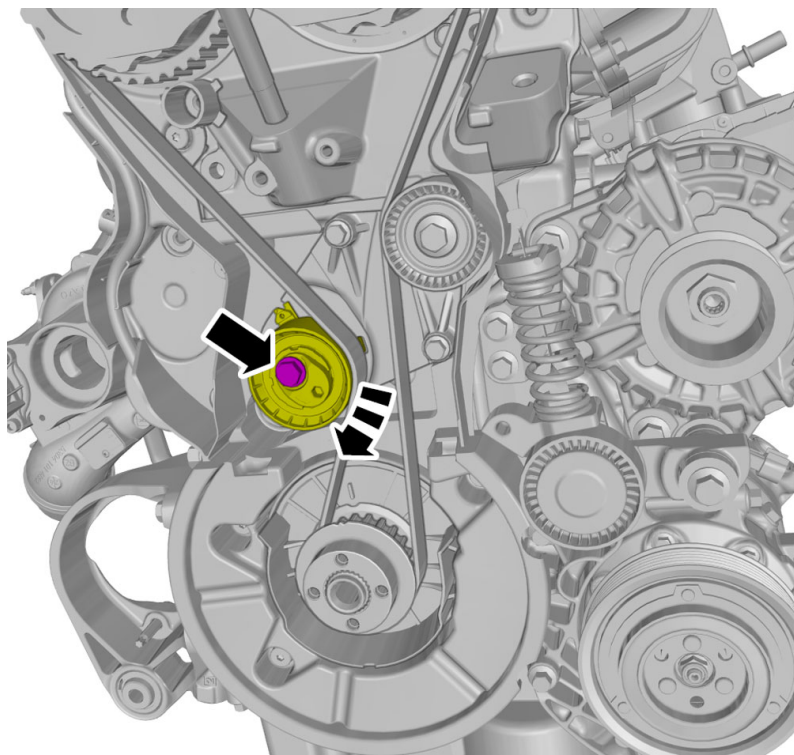

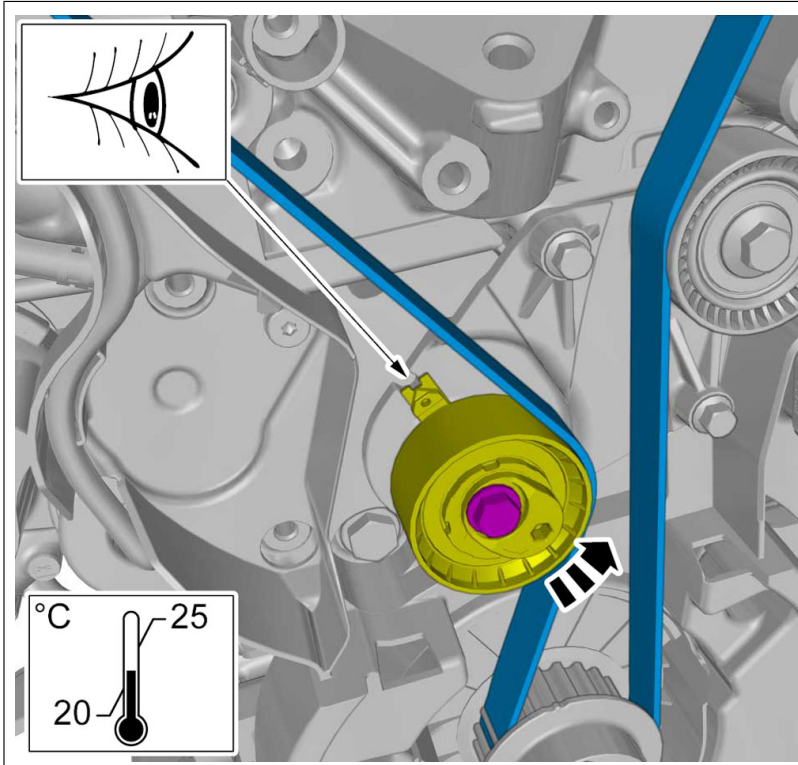

Note! The timing belt tensioner setting is dependant on the engine temperature.

Note! Make sure that the belt tensioner is aligned to the belt tensioner bracket.

Adjust to the specified value.

Use: Allen key

Tighten the screw.

Torque:

M8 , 24 Nm

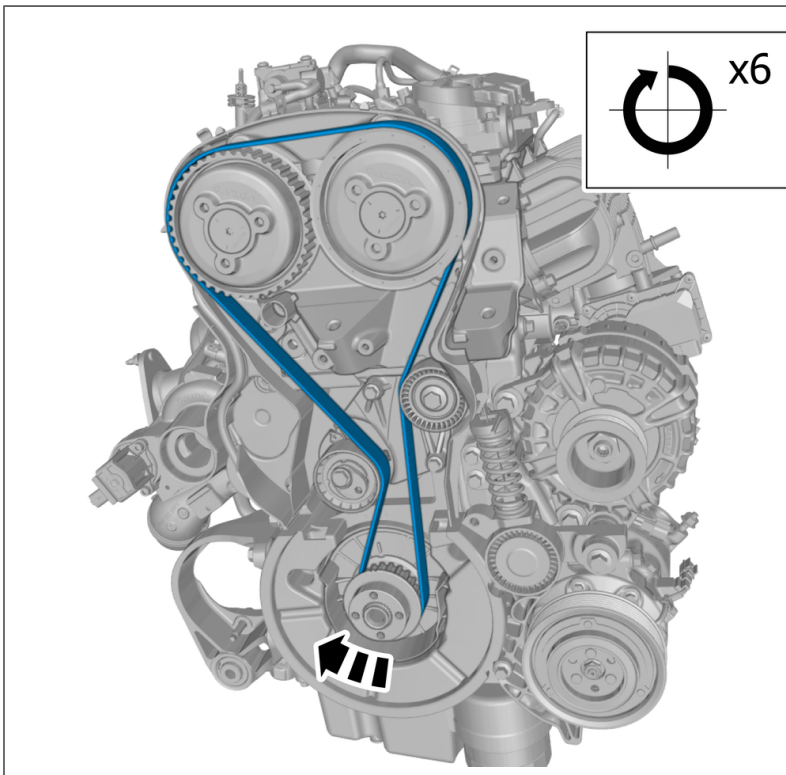

Note! The engine is rotated so that the belt assumes its correct position.

Turn the engine

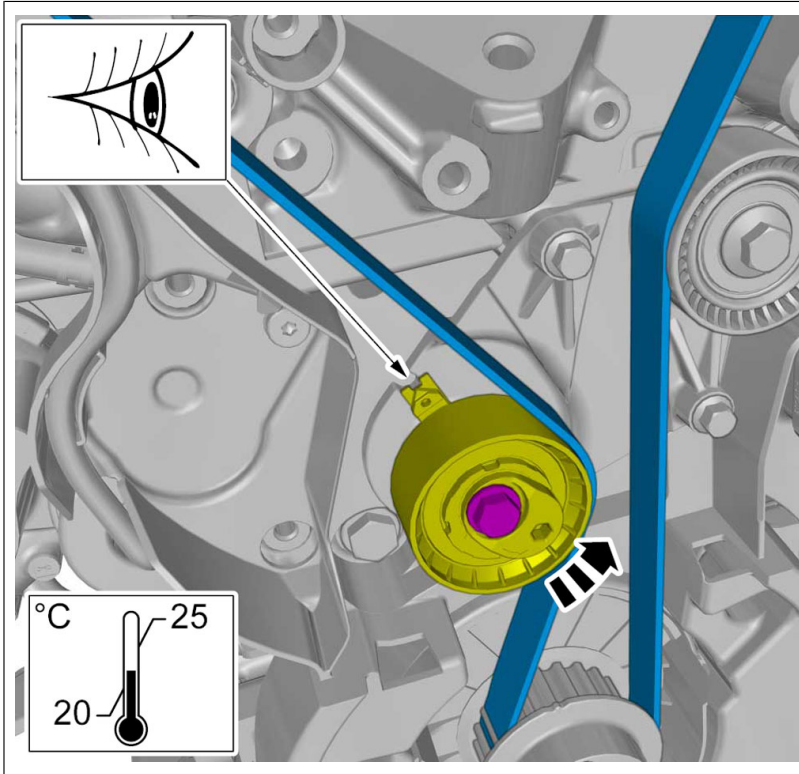

Caution! If the measured value is greater or less than the specified range, all steps in the Adjustment section must be carried out again.

Note! Make sure that the belt tensioner is aligned to the belt tensioner bracket.

Adjust to the specified value.

Installation

To install, reverse the removal procedure.