



Service Bulletin

File in Section: -

Bulletin No.: 16-NA-014

Date: January, 2016

TECHNICAL

Subject: Delayed Engagement After Sitting With Engine Off

Attention: This Bulletin also applies to any of the models that may be Export vehicles.

Brand:	Model:	Model Year:		VIN:		Engine:	Transmission:
		from	to	from	to		
Cadillac	Escalade	2015	2016				8L45 or 8L90
Cadillac	Escalade ESV	2016	2016				8L45 or 8L90
Cadillac	ATS	2016	2016				8L45 or 8L90
Cadillac	CTS	2016	2016				8L45 or 8L90
Chevrolet	Corvette	2015	2016				8L45 or 8L90
Chevrolet	Silverado	2015	2016				8L45 or 8L90
GMC	Sierra	2015	2016				8L45 or 8L90
GMC	Yukon	2015	2016				8L45 or 8L90
GMC	Yukon XL	2015	2016				8L45 or 8L90

Condition	<p>Some customers may comment on a condition of delayed engagement when the transmission is shifted from Park to Reverse or Park to Drive after the vehicle has been sitting with the engine off. This condition may typically occur after several hours or more commonly overnight.</p> <p>Customers may describe this condition as the vehicle not wanting to move or feeling like the transmission is slipping when first trying to move the vehicle. Operation will be normal and the condition will not occur until the vehicle sits again with the engine off for several hours or overnight.</p>
------------------	---

Correction

Install a new stator shaft support assembly that includes an additional check ball. Follow the instructions below to replace the stator shaft support assembly.

Service Procedure

1. Remove the transmission from the vehicle and mount to the DT-48989 transmission holding fixture. Refer to *Transmission Replacement* in SI.
2. Remove the 15 bolts (1) securing the fluid pan and gasket to the transmission.

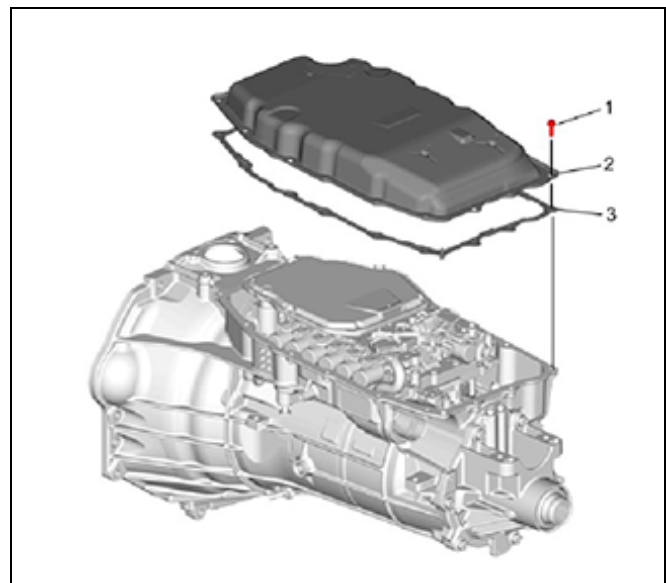

4358672

Note: The fluid pan gasket is reusable. Inspect the gasket to determine if it may be reused. If the gasket is stuck to the case or pan, it should be replaced.

- Remove the fluid pan (2) and gasket (3). The fluid filter does not need to be removed.

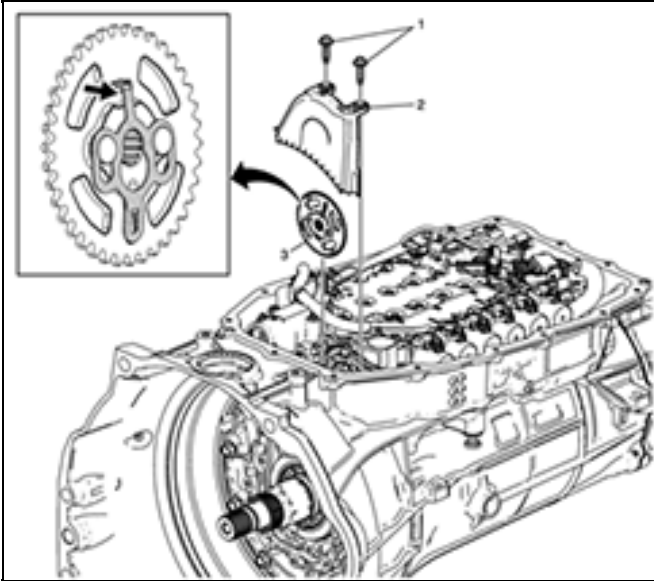

4358767

- Using the DT-48285 Torx Plus socket, remove the two fluid baffle bolts (1) and fluid baffle (2). Discard the bolts.

Note: The driven sprocket locking tab is located on the back of the sprocket. Rotate the sprocket as shown and simultaneously pull back and up on the tab to release the retainer.

- Remove the driven sprocket (3) from the oil pump shaft leaving the drive link (chain) loose in the case.

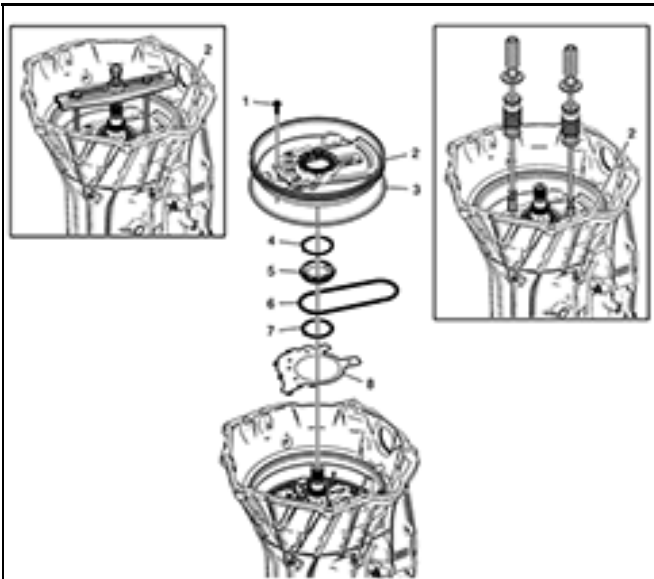

4358769

- Remove the 11 front cover bolts (1). Discard the bolts. The bolts have a dry sealant on them and may only be used once.

Note: There are 2 different front cover configurations. Early design front covers have 3 threaded holes for service, late design front covers have 2 threaded holes.

- Use two *GE-6125-1B* slide hammers and *DT-51791* slide hammer adapters in the threaded holes of the front cover to remove it from the case for applications with 3 threaded holes.
 - Use the *GE-8433* puller bar and 2 bolts in the threaded holes of the front cover to remove it from the case for applications with 2 threaded holes.
- Remove the front cover (2) and seal (3). Inspect the seal and replace if worn or damaged.
 - Remove the drive sprocket (5).
 - Remove the drive link assembly (6).
 - Remove the front support cover gasket (8). Discard the gasket.
 - Inspect the front (4) and rear (7) drive sprocket thrust washers. Replace if worn or damaged.

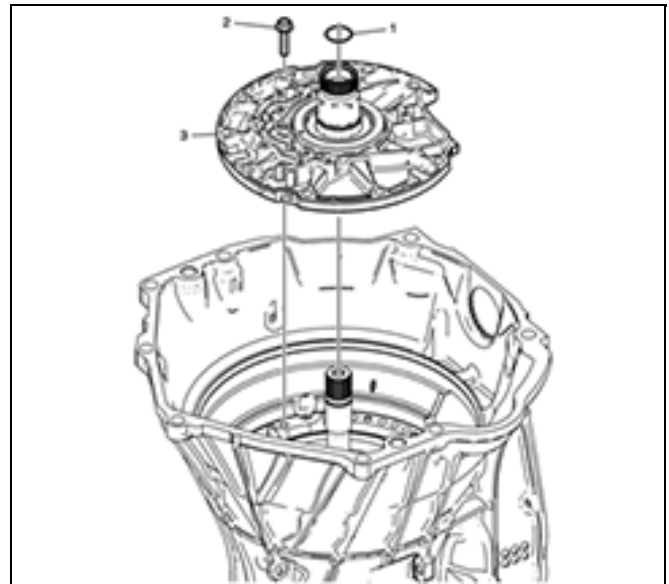

4358771

- Remove the turbine shaft O-ring seal (1). Discard the seal.
- Remove the nine stator shaft support bolts (2).
- Remove the stator shaft support assembly (3).

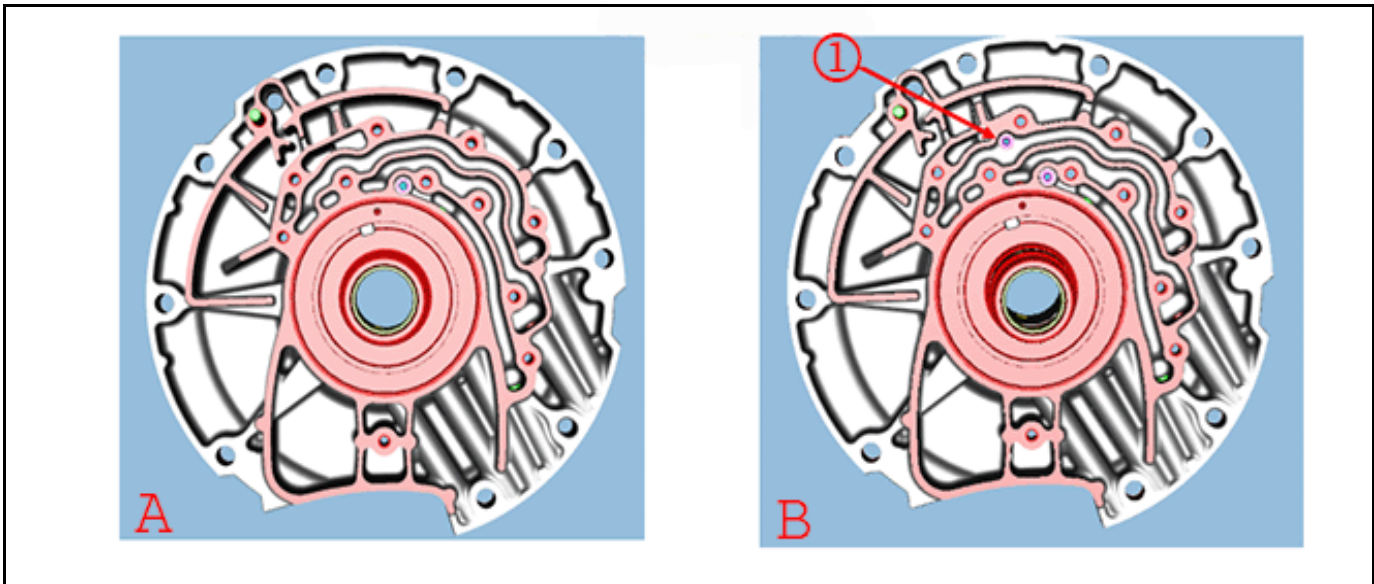

4358773

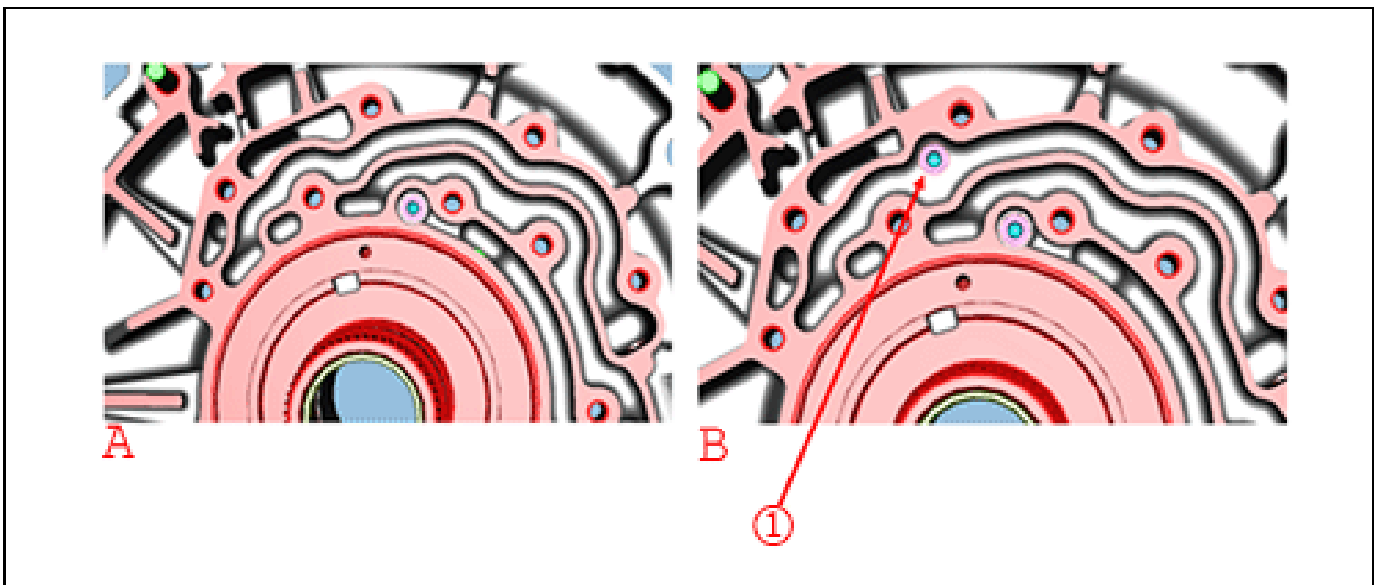

4358775

Legend

(A) Old stator support asm 24274636/
24275106/24272656

(B) New stator support asm 24277234

Note: The new stator shaft support assembly has a second check ball (1) added (see illustrations).

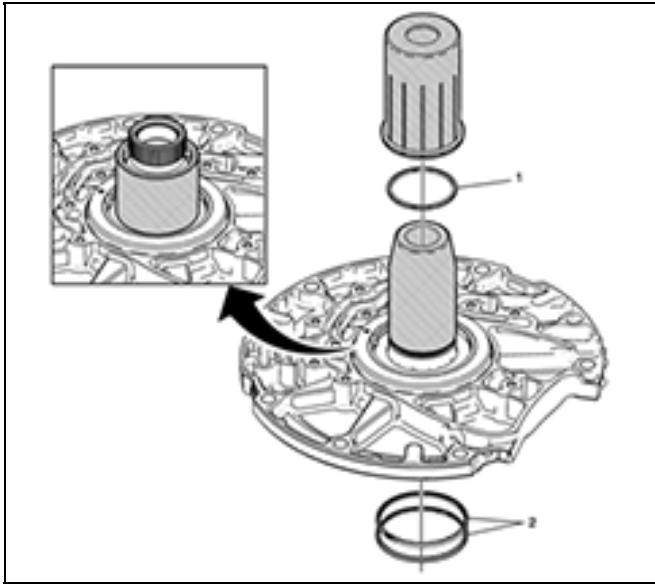

4358778

Caution: Size the converter fluid seal ring for at least 5 minutes after installation to obtain proper seal ring size. Failure to do so may cause internal transmission leaks and transmission damage.

Note: Use the large taper side of *DT-50912-1* Seal Sizer for initial seal sizing, then flip the tool over for final sizing. The *DT-50912-1* seal sizer works for both the 8L90 and 8L45.

15. Using the *DT-50912* Seal Installer (8L90) or *DT-51196* Seal Installer (8L45), install a NEW torque converter fluid seal (1) on the stator shaft support assembly. Size the seal using the *DT-50912-1* Seal Sizer.
16. Install 2 NEW 1-3-5-6-7 Clutch Fluid Seal Rings (2).

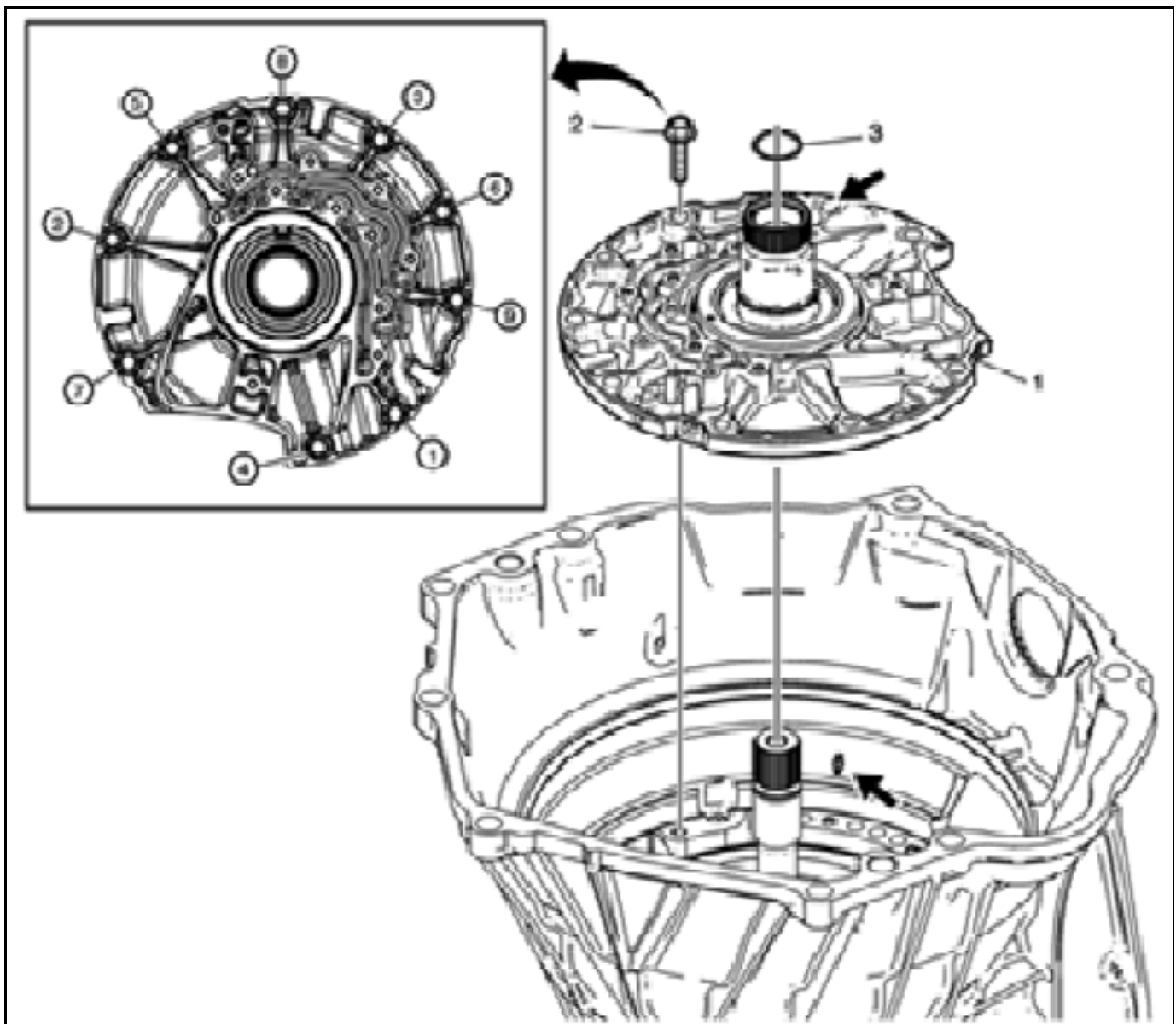

4358780

Note: Align the bolt hole indicated by the arrow with the arrow that is cast into the case and push down to seat.

17. Install the NEW stator shaft support assembly (1).
18. Install the nine stator shaft support bolts (2). Tighten the bolts in the sequence shown. Tighten the bolts to **31 N•m (23 lb ft)**.
19. Install a NEW turbine shaft O-ring seal (3).

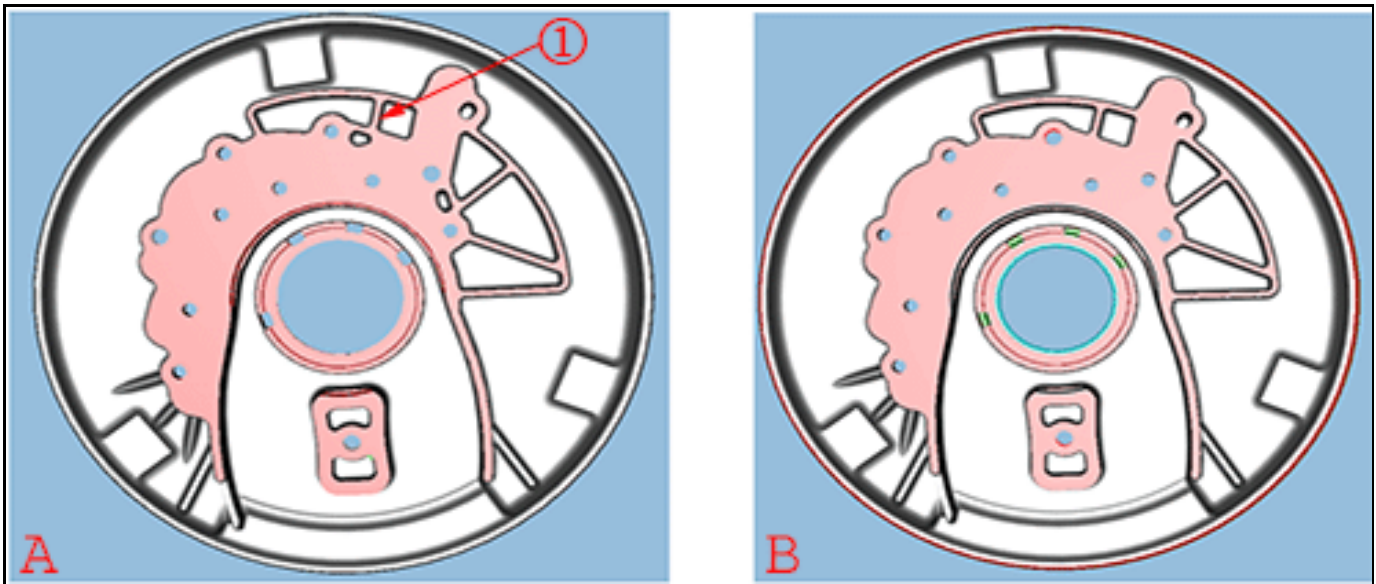

4358782

Legend

(A) Old cover 24272660

(B) New cover 24277964

Note: The casting void has been eliminated from the underside of the cover (see illustration).

- 20. Using the *DT-43772* Torque Converter Seal Installer, install a NEW torque converter fluid seal (1) on the front cover.

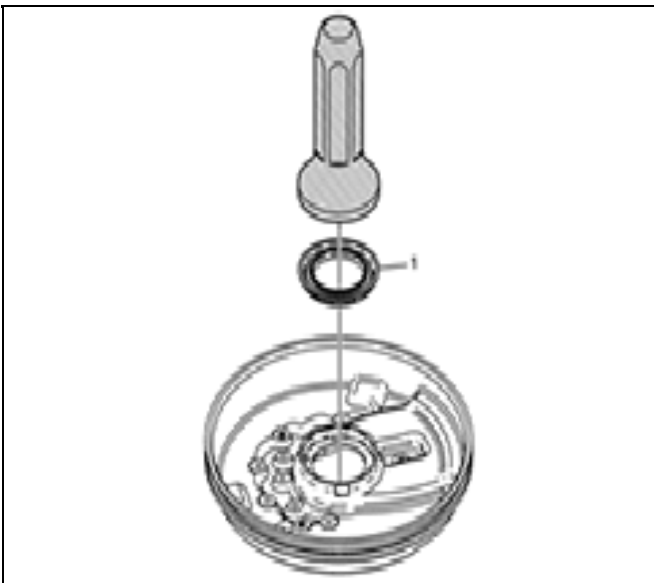

4358784

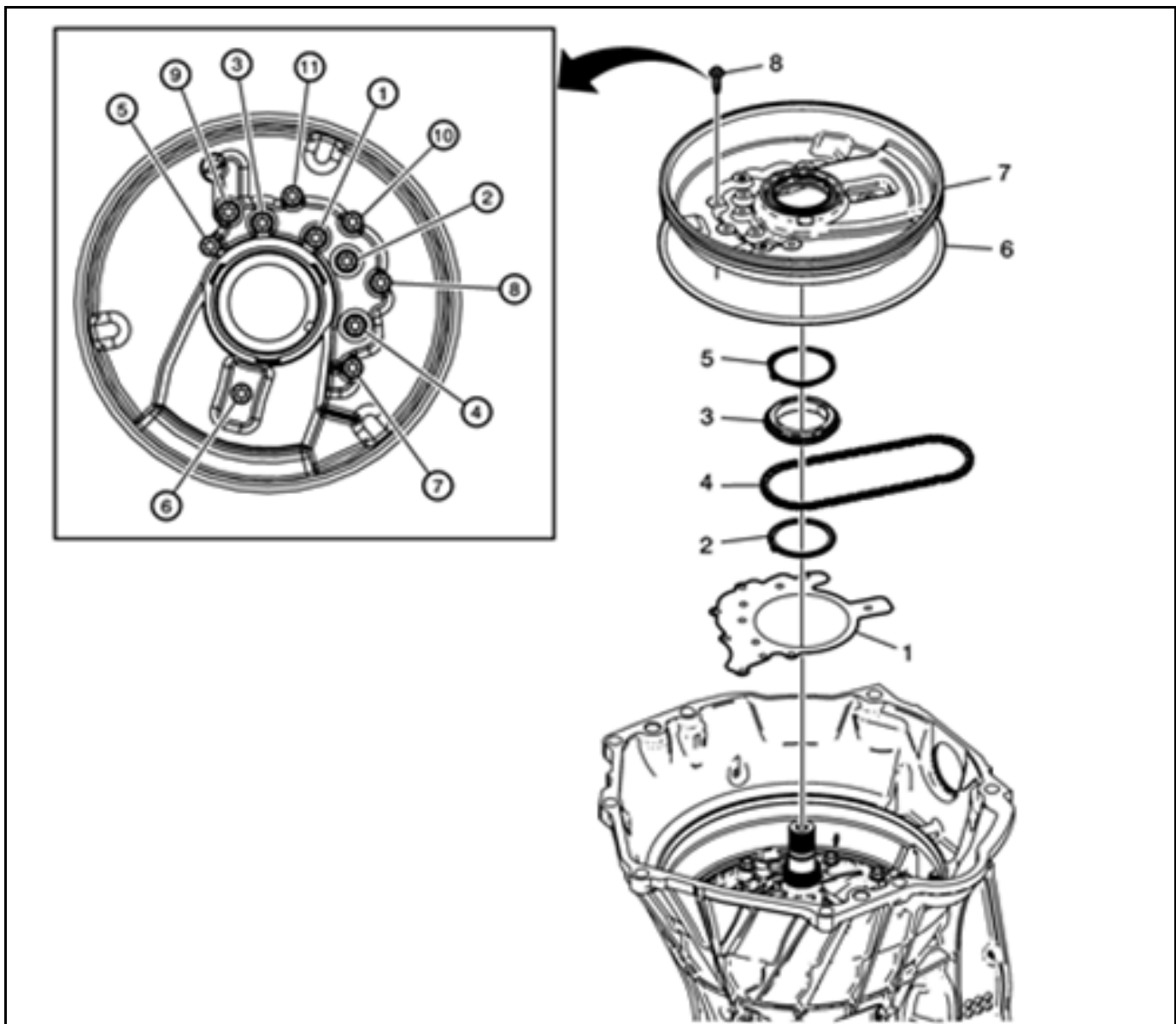

21. Install a NEW front support cover gasket (1).
22. Install the (rear) drive sprocket thrust washer (2) on the stator shaft support assembly.
23. Install the drive sprocket (3) and drive link assembly (4).
24. Install the (front) support cover gasket (5) on the front cover (7).
25. Install the front cover seal (6) on the front cover (7).

Note: Ensure the drive link assembly is not pinched by the front cover and moves freely on the drive sprocket.

26. Install the front cover (7).
27. Install the 11 NEW front cover bolts (8). Gradually tighten the bolts in the sequence shown. Tighten the bolts a first pass to **6.5 N•m (58 lb in)**. Tighten the bolts a final pass **30 Degrees**.

4358787

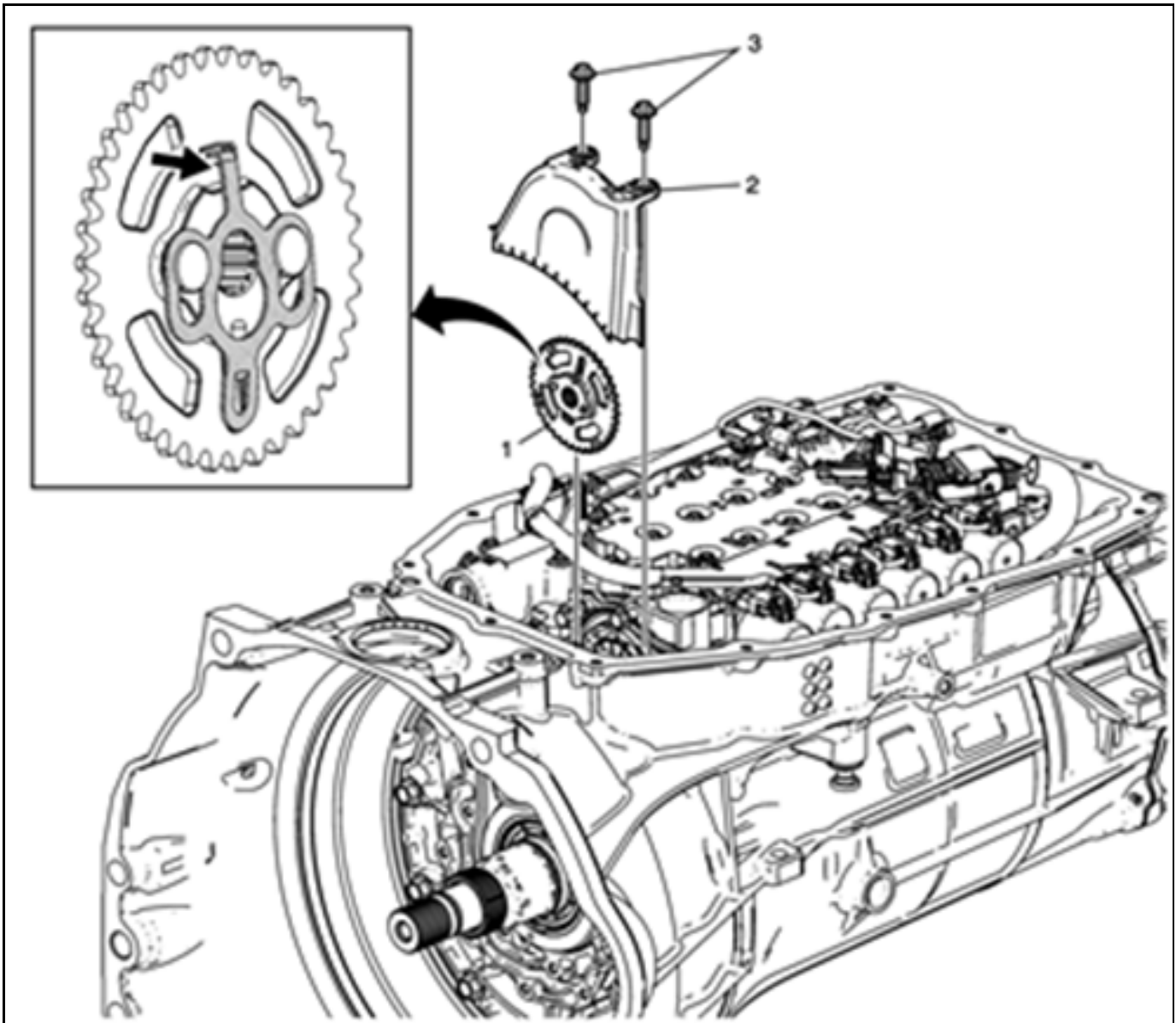

4358789

Note: Ensure the driven sprocket locking tab is in the unlocked position before installing the sprocket. The driven sprocket locking tab is located on the back of the sprocket and faces the pump.

28. Install the drive link (chain) to the driven sprocket (1) and then install the driven sprocket to the oil pump shaft. Rotate the sprocket as shown and push down on the tab until it locks the driven sprocket in place.
29. Install the fluid baffle (2).
30. Using the DT-48285 Torx Plus socket, secure the baffle using two NEW fluid baffle bolts (3). Tighten the bolts a first pass to **4 N•m (35 lb in)**. Tighten the bolts a final pass to **45 degrees**.

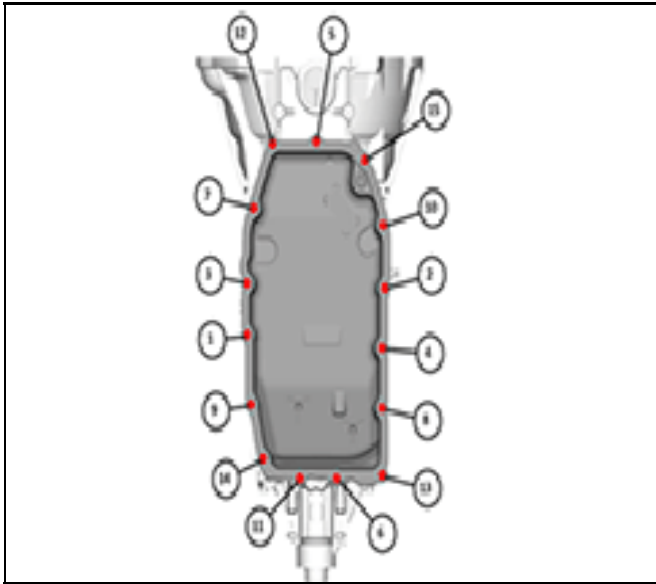

4358796

31. Install the fluid pan and gasket and secure with 15 bolts. Tighten the bolts to **10 N•m (89 lb in)** in the sequence shown.
32. Install the transmission into the vehicle. Refer to *Transmission Replacement* in SI.

Parts Information

Description	Part Number	Qty	Trans Model	Component Number in Disassembled Views
GASKET-A/TRNS FLUID PAN	24260071	1 (if required)	8L45/8L90	48
BOLT/SCREW-A/TRNS FLUID BFL	11548404	2	8L45/8L90	12
BOLT/SCREW-A/TRNS CASE FRT CVR	11548201	11	8L45/8L90	3
SEAL-A/TRNS CASE FRT CVR	24266366	1 (if required)	8L90	5
SEAL-A/TRNS CASE FRT CVR	24251906	1 (if required)	8L45	5
GASKET-A/TRNS FRT SUPT CVR	24272658	1	8L90	19
GASKET-A/TRNS FRT SUPT CVR	24264863	1	8L45	19
WASHER-DRV SPKT THR (FRONT)	24259119	1 (if required)	8L45/8L90	6
WASHER-DRV SPKT THR (REAR)	24259427	1 (if required)	8L45/8L90	8
SEAL-TURB SHF (O RING)	24261849 (Part of 24271697 kit)	1	8L90	500
SEAL-TURB SHF (O RING)	24261848 (Part of 24277071 kit)	1	8L45	500
SUPPORT ASM-STATOR SHF	24277234	1	8L90	14
SUPPORT ASM-STATOR SHF	24277230	1	8L45	14

Description	Part Number	Qty	Trans Model	Component Number in Disassembled Views
COVER-A/TRNS CASE FRT	24277964	1 (if required)	8L90	4
SEAL-T/CV FLUID	24259216	1	8L45/8L90	18
RING-1-3-5-6-7 CLU FLUID SEAL	24266593	2	8L90	15
RING-1-3-5-6-7 CLU FLUID SEAL	24266594	2	8L45	15
SEAL ASM-T/CV FLUID	24266709	1	8L45/8L90	2
FLUID, A/TRANS (DEXRON HP ATF) (1 QUART)	19300536-US 19300537-CA	As Required	8L45/8L90	

Warranty Information

Labor Operation	Description	Labor Time
8465020	Stator Shaft Support Replacement	Use Published Labor Operation Time

Version	1
Modified	

GM bulletins are intended for use by professional technicians, NOT a "do-it-yourselfer". They are written to inform these technicians of conditions that may occur on some vehicles, or to provide information that could assist in the proper service of a vehicle. Properly trained technicians have the equipment, tools, safety instructions, and know-how to do a job properly and safely. If a condition is described, DO NOT assume that the bulletin applies to your vehicle, or that your vehicle will have that condition. See your GM dealer for information on whether your vehicle may benefit from the information.



WE SUPPORT VOLUNTARY
TECHNICIAN
CERTIFICATION