



# Service Bulletin

## INFORMATION

**Subject:** Rattle Noise From Second Row Seat

**Models:** 2015-2016 Cadillac Escalade Models  
2015-2016 Chevrolet Suburban, Tahoe  
2015-2016 GMC Yukon Models

*This PI was superseded to update the Models, Condition and Recommendations sections. Please discard PIT5284.*

The following diagnosis might be helpful if the vehicle exhibits the symptom(s) described in this PI.

### Condition/Concern

Some customers may comment on any of the following conditions with the second row seat:

- A rattle may occur from the seat when driving over bumps.
- When releasing the seat bottom it will not flip forward or must be assisted up off the latches before it will flip forward.

These conditions may be caused by any of the following:

Cause 1: The striker is not properly aligned in the latch opening, see picture below. This could cause a rattle or the striker to drag on the side of the latch opening not allowing the seat to flip forward or latch down

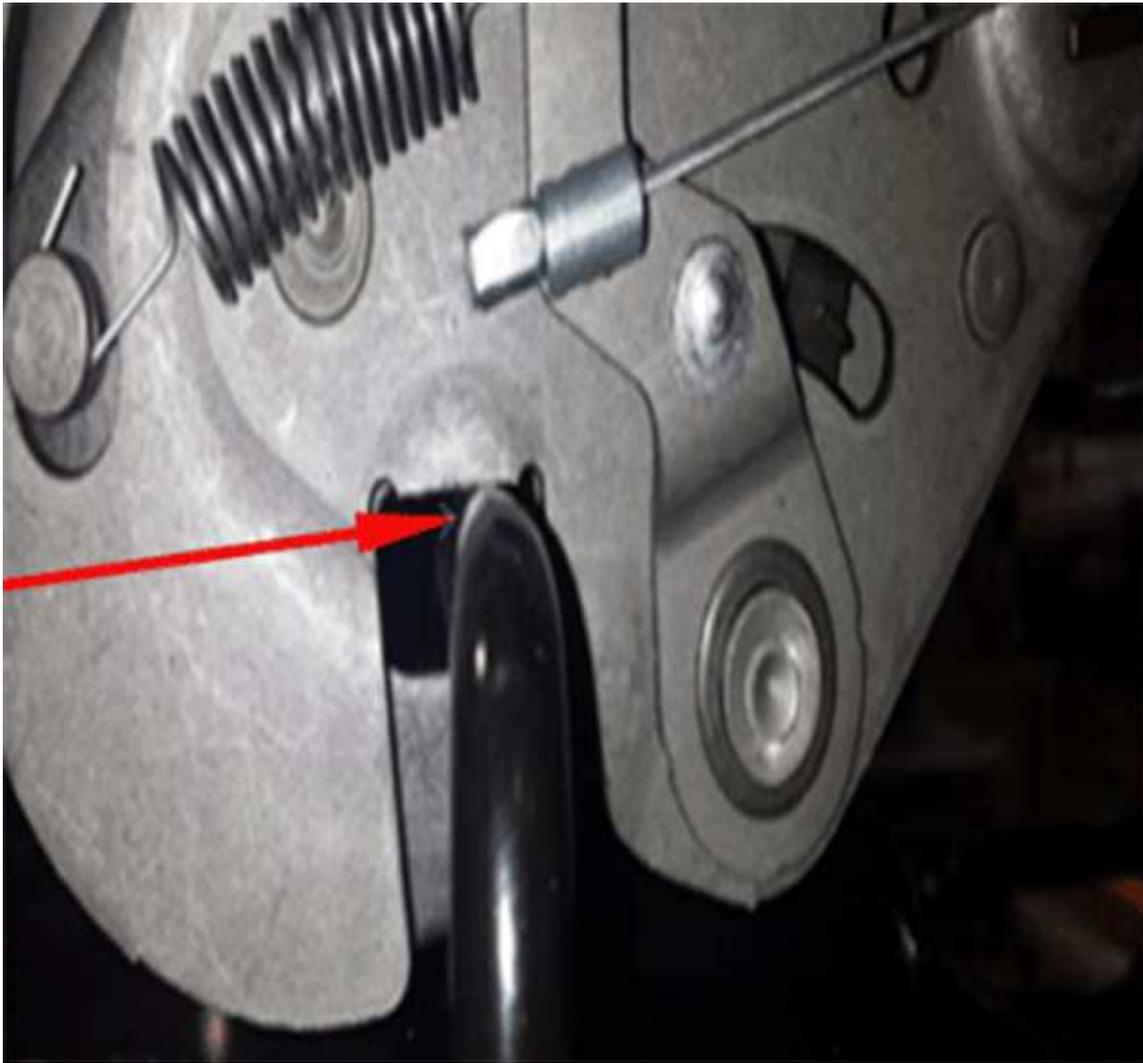

Cause 2: A seat bottom latch (inboard and/or outboard latch) may have an unequal latch opening for the striker to seat into. See picture below, opening (1) may protrude down farther than opening (2), which can cause a rattle. With the seat latched down, if the striker to latch interface is inspected on both sides of a latch, there will be a gap on one side of the latch and no gap on the other side of the same latch.

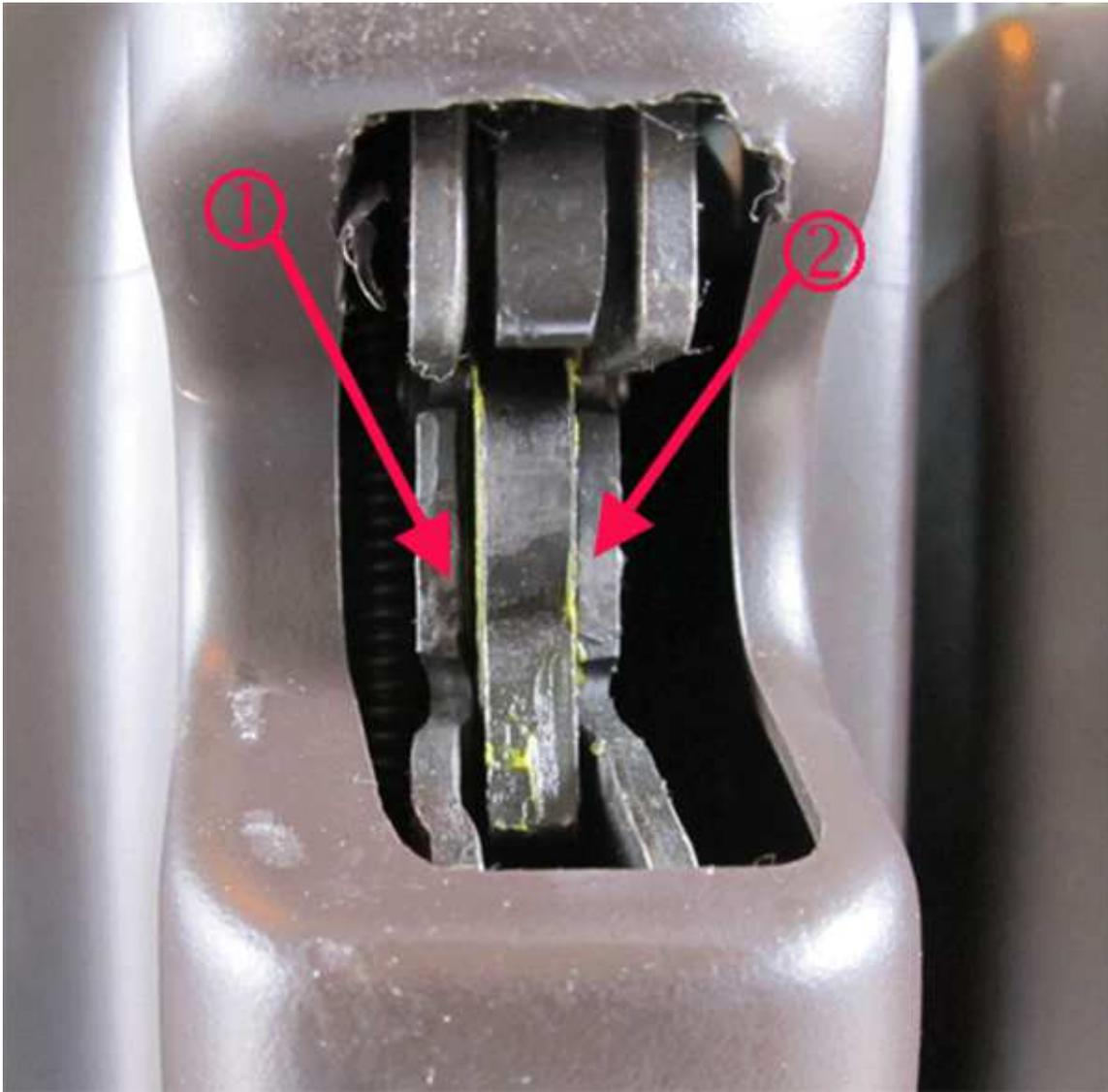

Cause 3: Inboard to outboard striker height variations, causing uneven gapping between the left and right seat bottom latches, see picture below. This can cause the latch with the gap to rattle.

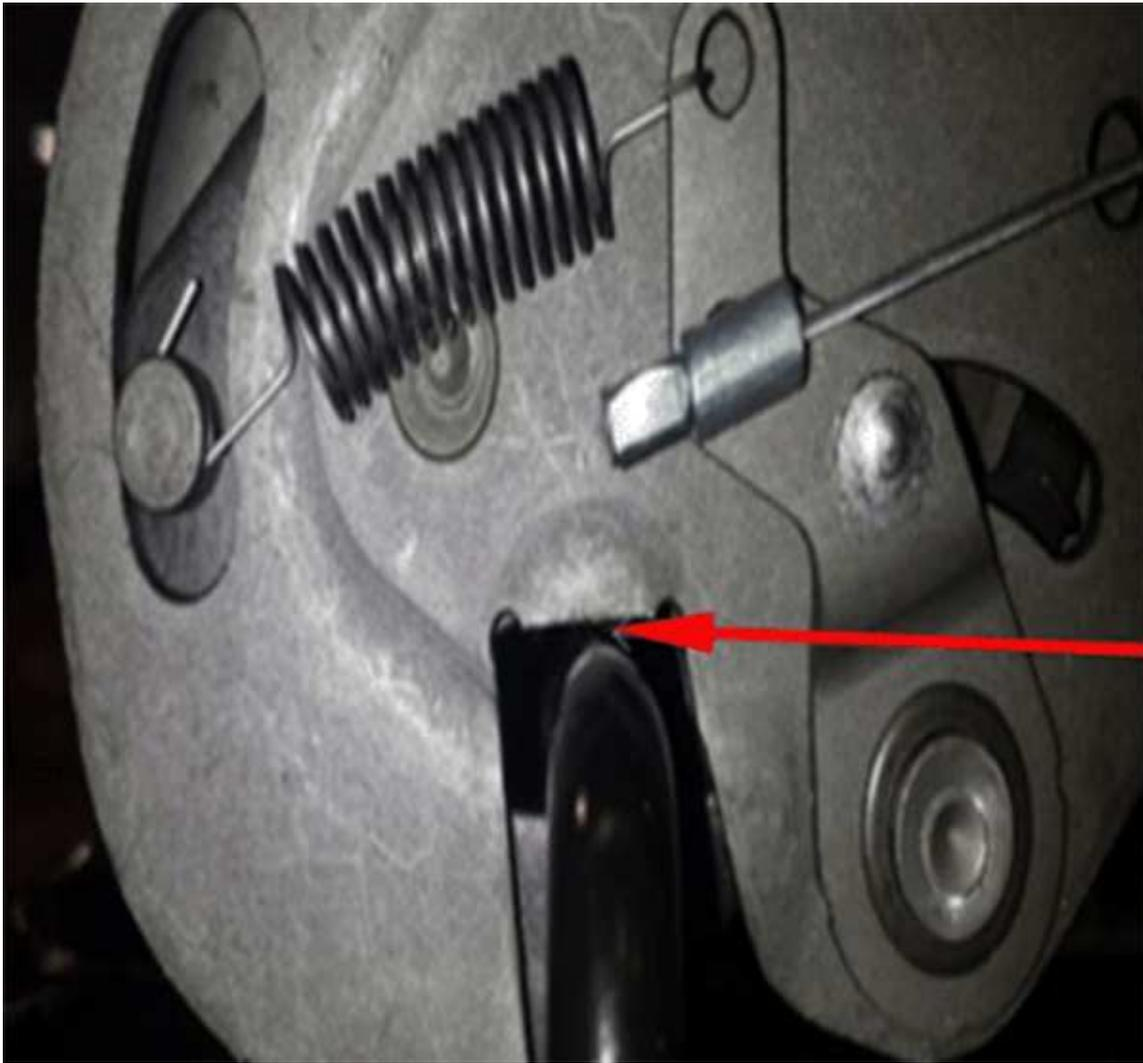

Cause 4: The seat base plate contacting/rattling against the ribs of the floor pan.

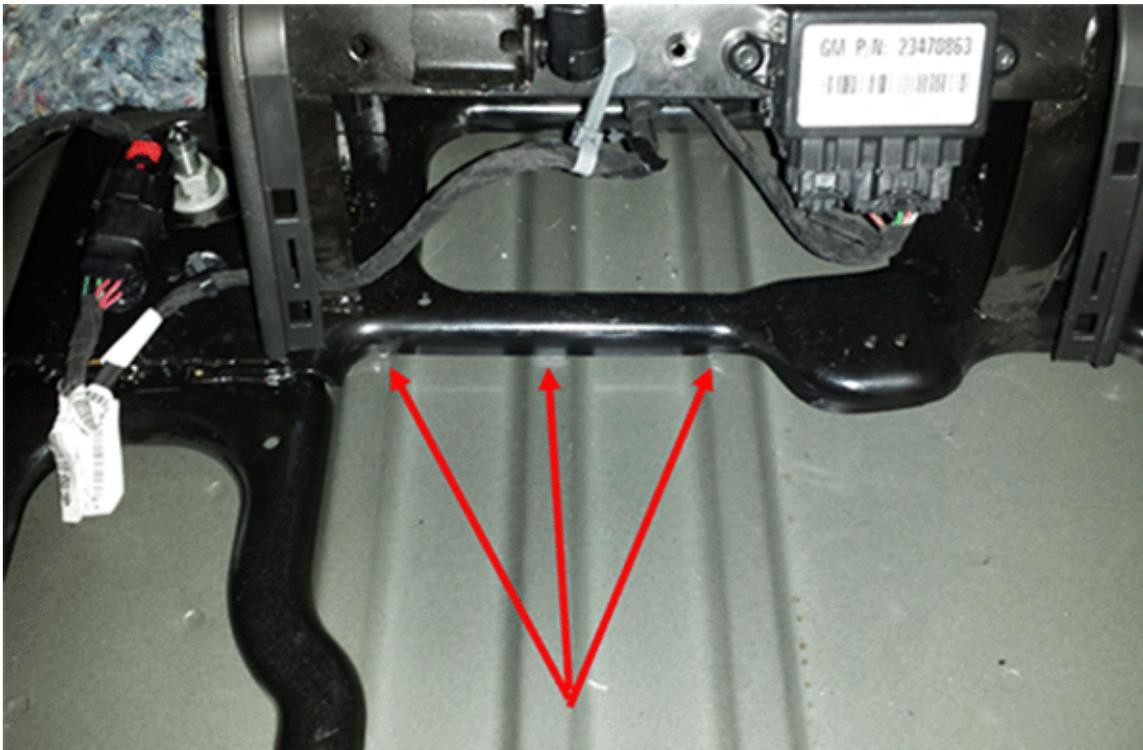

**Recommendation/Instructions**

- Cause 1: The striker is not properly aligned in the latch opening

1.1 To repair this condition, rework/adjust the striker in the direction to center it in the latch opening. An adjustable wrench may be used to rework/adjust the striker, as shown below.



- Cause 2: A seat bottom latch (inboard and/or outboard latch) may have an unequal opening for the striker to seat into.

This procedure will form the protruding latch opening to the striker, which will allow the two opening to be equal/parallel to each other so the striker contacts both openings.

2.1 With the second row seat in the latched down position, inspect both sides of the same latch for striker to latch gapping, as shown. If gapping is present, perform the following to align the latch openings to the striker.

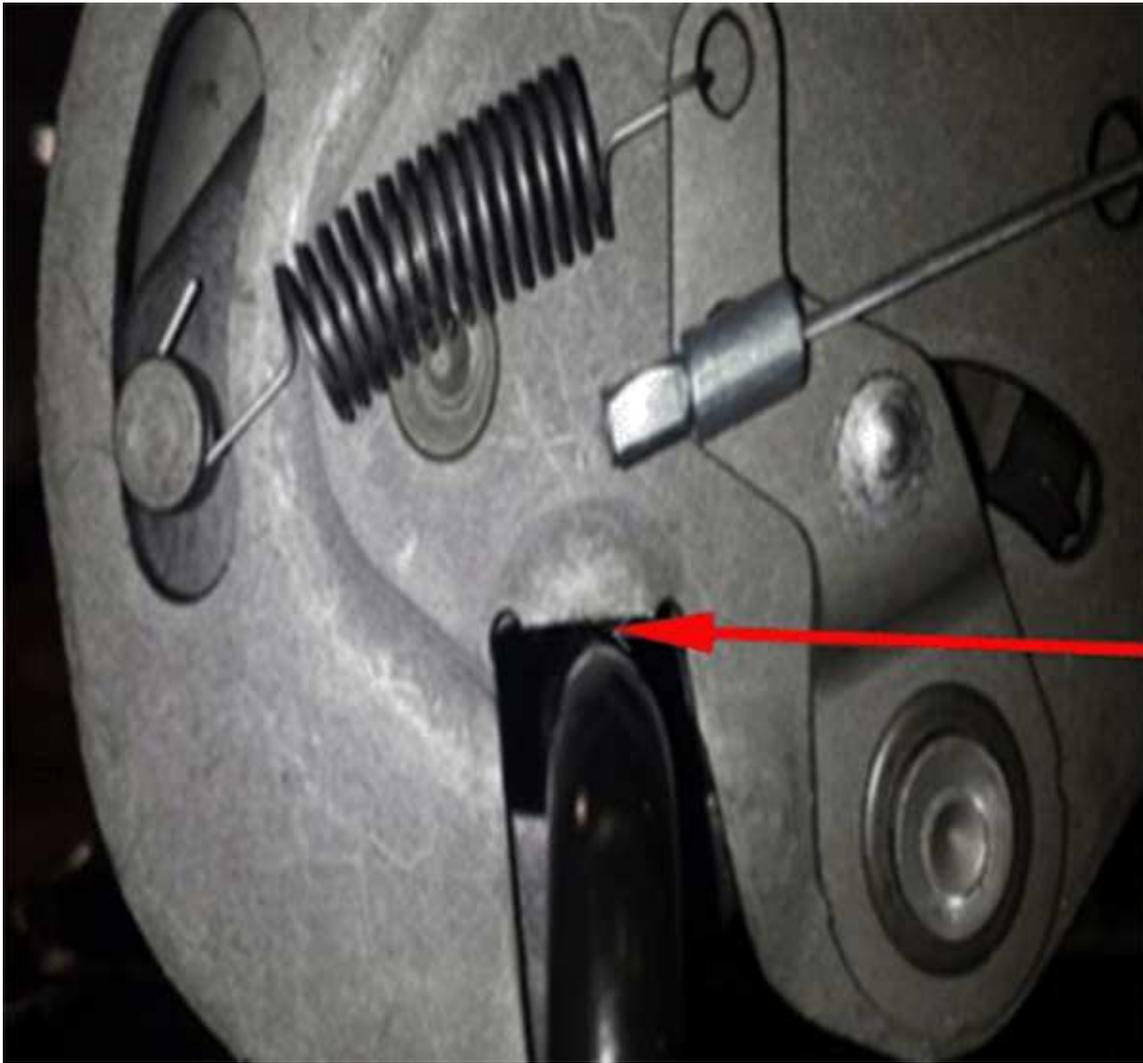

2.2 With the affected seat in the tumbled forward position, “forcefully” slam the seat down into the latched position.

2.3 Repeat this procedure 3 to 4 times.

2.4 Latch the seat down using normal force and verify the rattle noise and/or latching condition is corrected.

2.5 If the rattle noise and/or latching condition is still present, repeat steps 1-3 one additional time, see note below.

**Note:** Do NOT over slam or repeat steps 2.2 more than recommended as damage to the seat bottom latch or striker may occur. If this step does not correct the concern then it is not the root cause of the issue and do not continue to slam the seat.

- Cause 3: Inboard to outboard striker height variations, due to an unlevel seat base plate, can cause uneven gapping between the inboard to outboard striker to latch, shown below.

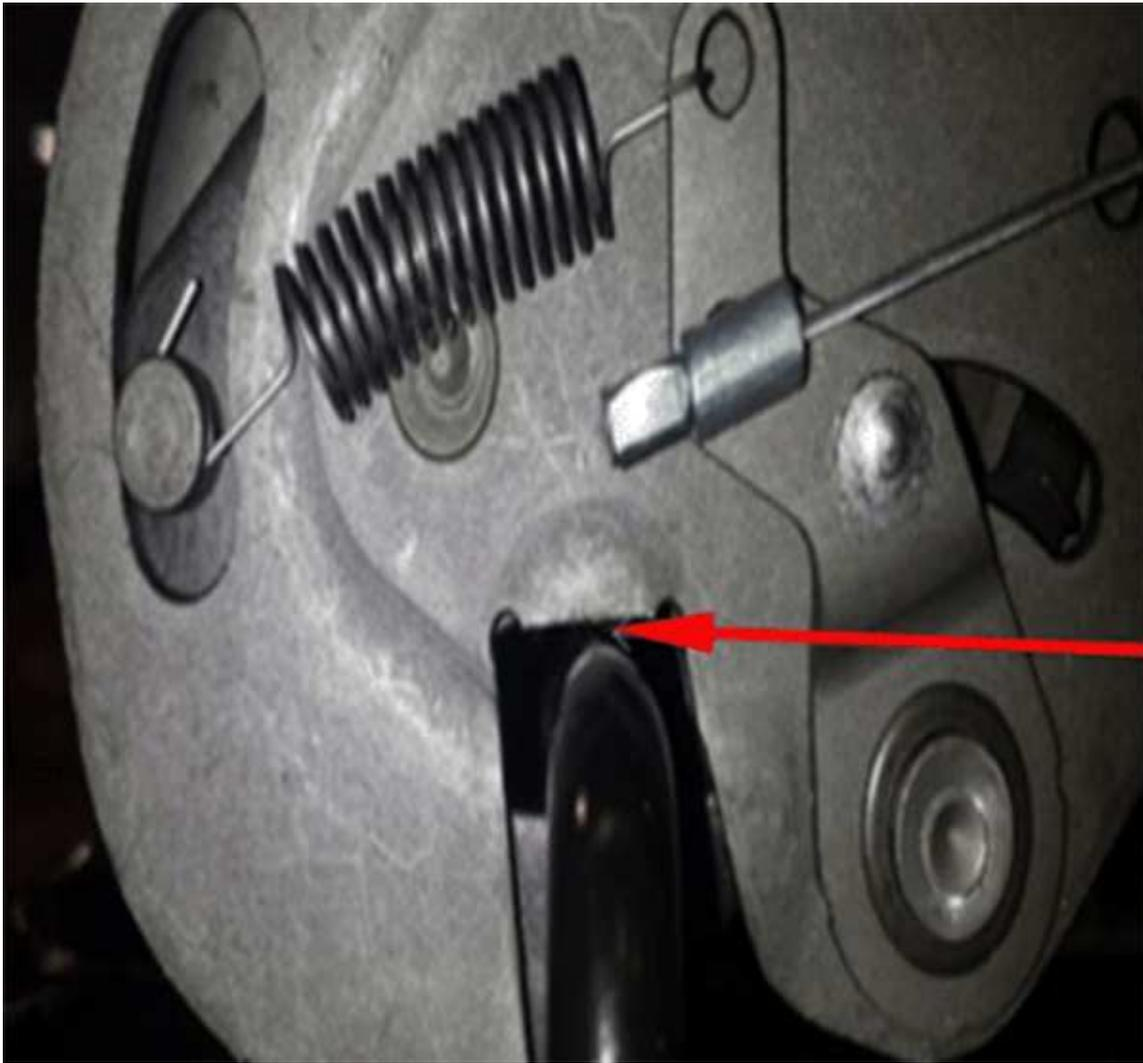

This procedure will level the seat base plate by installing spacer washers between the floor and seat base plate.

3.1 Place the affected seat into the flipped forward position.

3.2 Slowly lower the seat to rest the latches on their strikers; Do Not allow the seat to latch. Observe the seat latches to mating strikers for even contact or gap.

3.3 If a gap is present between one of the latches and the mating striker, continue to next step. If there is even contact with no gaps between the inboard and outboard striker to latch, the seat base plate is level and this is not the root cause of the noise.

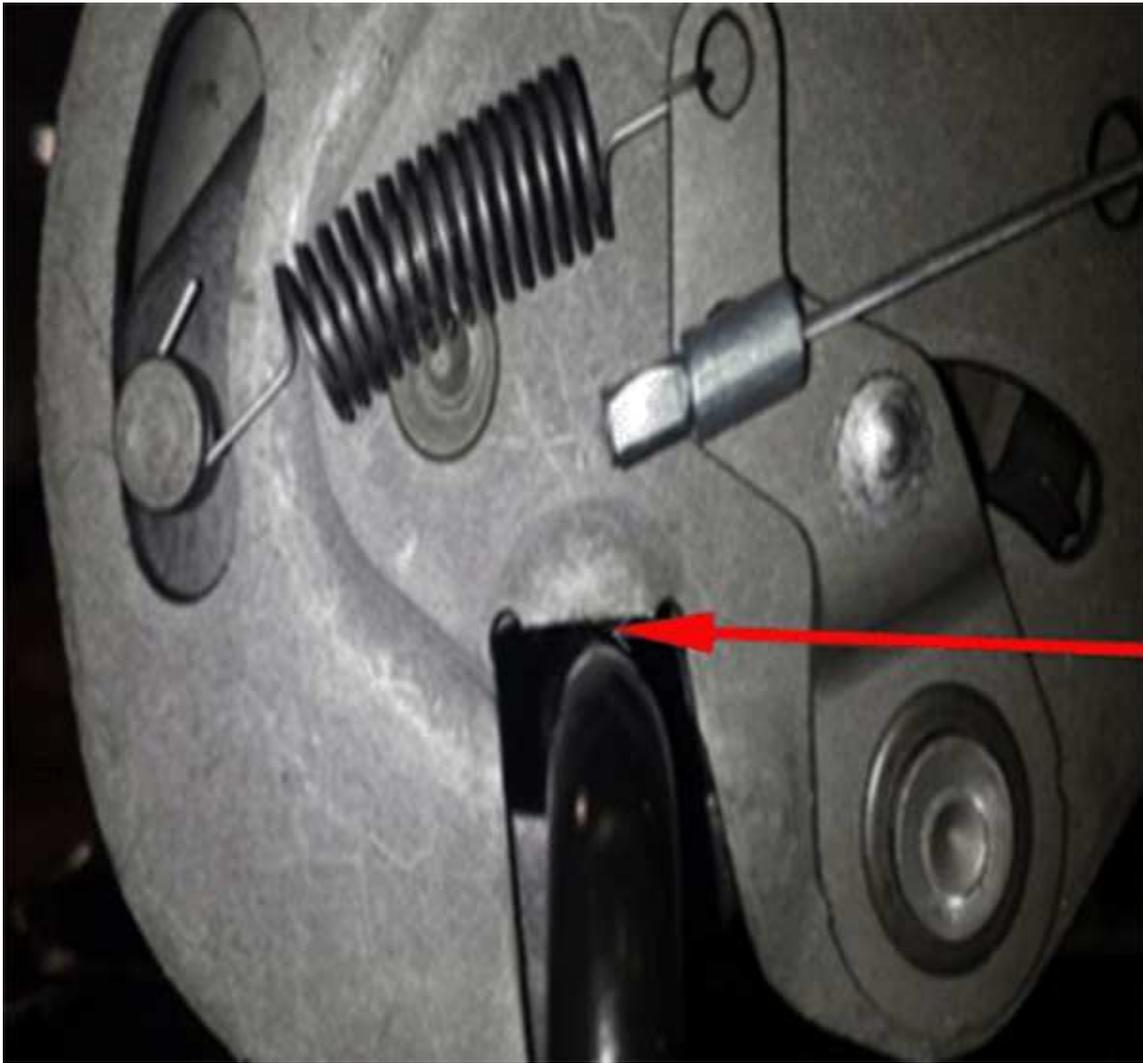

3.4 Measure the gap to determine the appropriate number of spacer washers required to adjust the seat base plate (2) to be level.

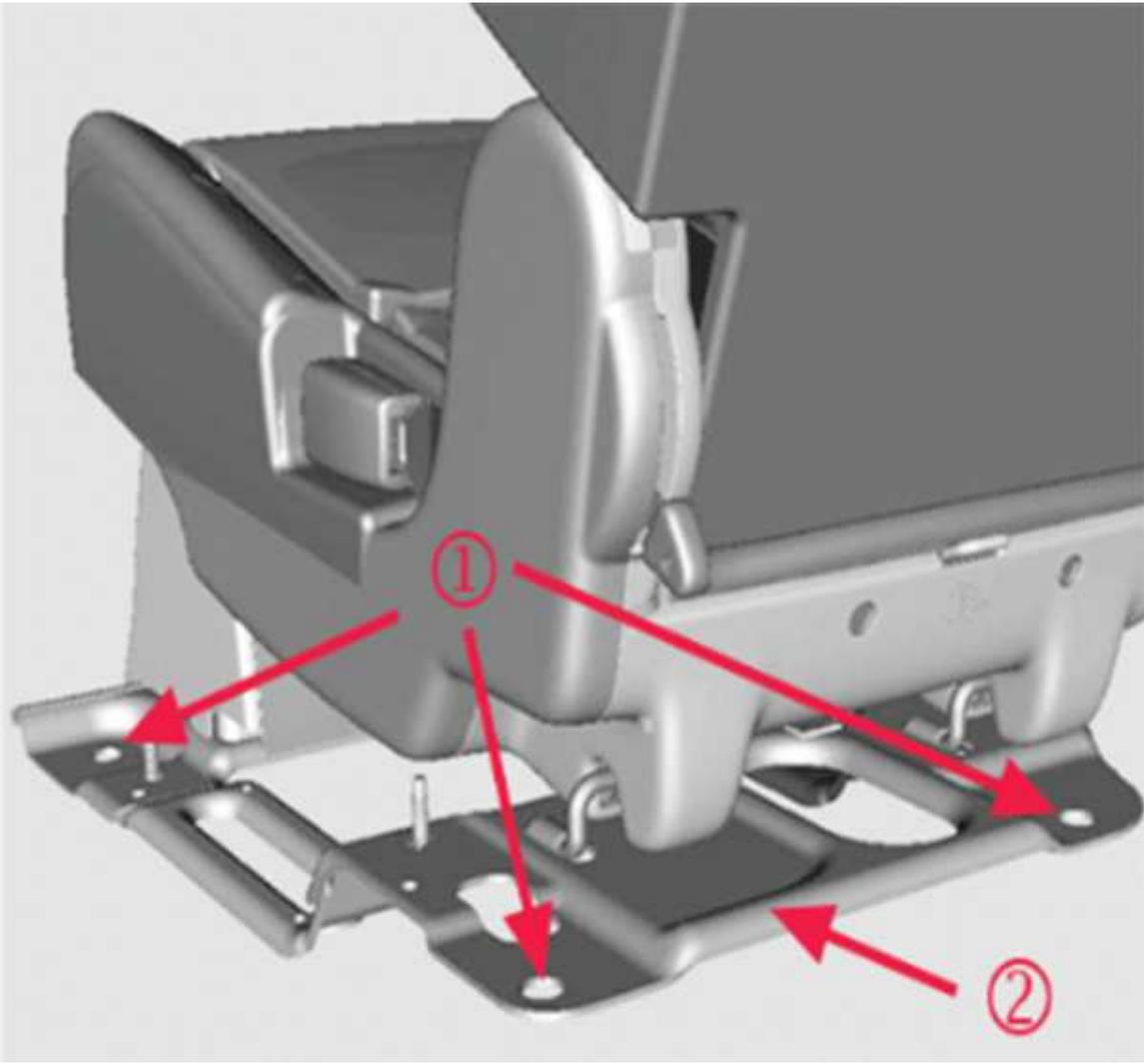

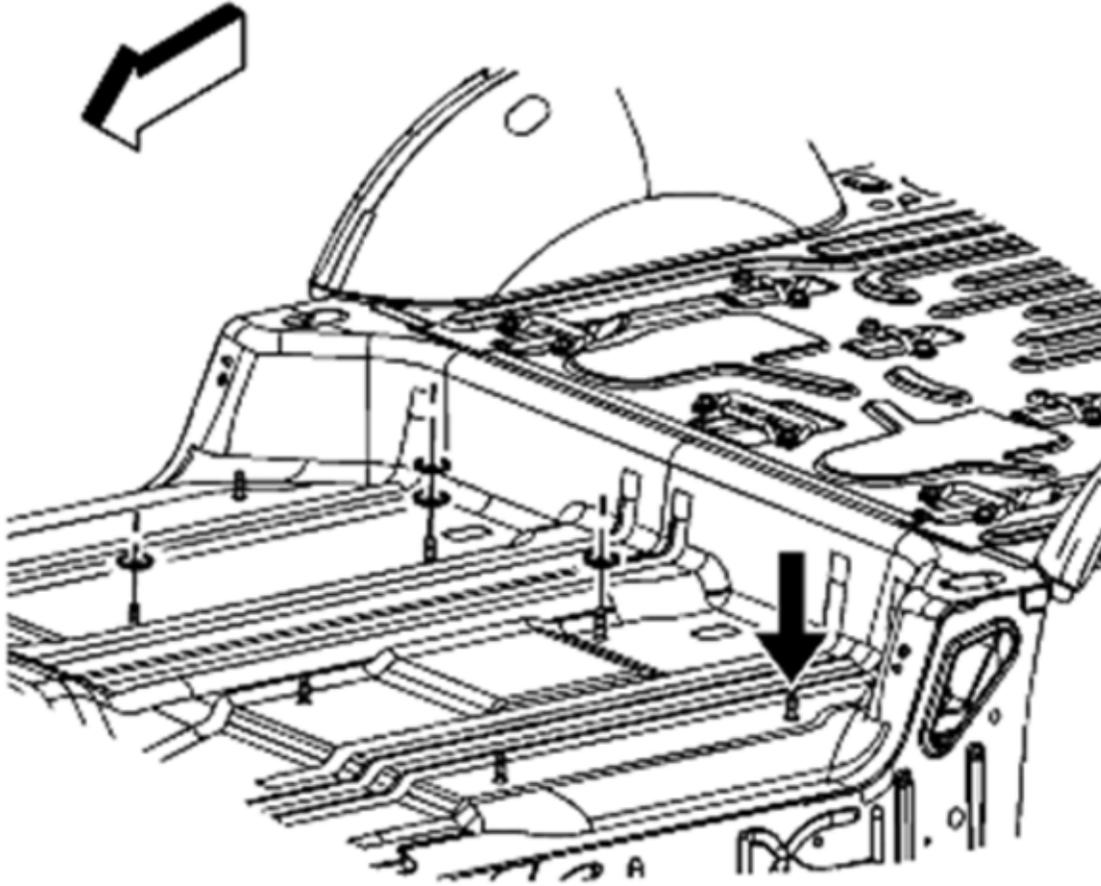

**Important:** For any mounting stud location (1) requiring spacer washers, ensure a minimum of three threads of the stud will be exposed once the nuts have been tightened to specification.

- If the latch to striker gap is 3 mm (0.118 in) or less, add one washer.
- If the gap is greater than 3 mm (0.118 in), add two washers.

**Note:** It is possible that depending on the floor pan, spacer washers might be needed at one of the forward stud locations as well as, or instead of, at a rear location.

**Important:** If there are washers already present on the studs leave them in place.

3.5 Remove all the seat mounting nuts and lift the seat assembly to add the spacer washers to the appropriate mounting stud nearest the striker that had a gap to the latch. Review the issue in step 4 while the seat is removed.

3.6 Reinstall the seat and nuts. Tighten the nuts to 45 Nm (33 lb ft).

**Important:** There must always be a minimum of 3 exposed threads of the stud past the end of the nut once it is fully seated and tightened to specification.

3.7 Verify proper seat operation by completing the following steps:

- Cycle the seat to be fully latched, then release the latches and move the seat to the tumbled forward, or raised position.
- Repeat step 3.2 to inspect the latch gapping, it may be necessary to adjust locations and/or quantity of the spacer washers; possibly including using the forward stud locations as needed to level out the seat riser plate.

Cause 4: The seat base plate contacting/rattling against the ribs of the floor pan.

4.1 Remove the Rear Seat Riser Opening Finish Cover (2), shown below.

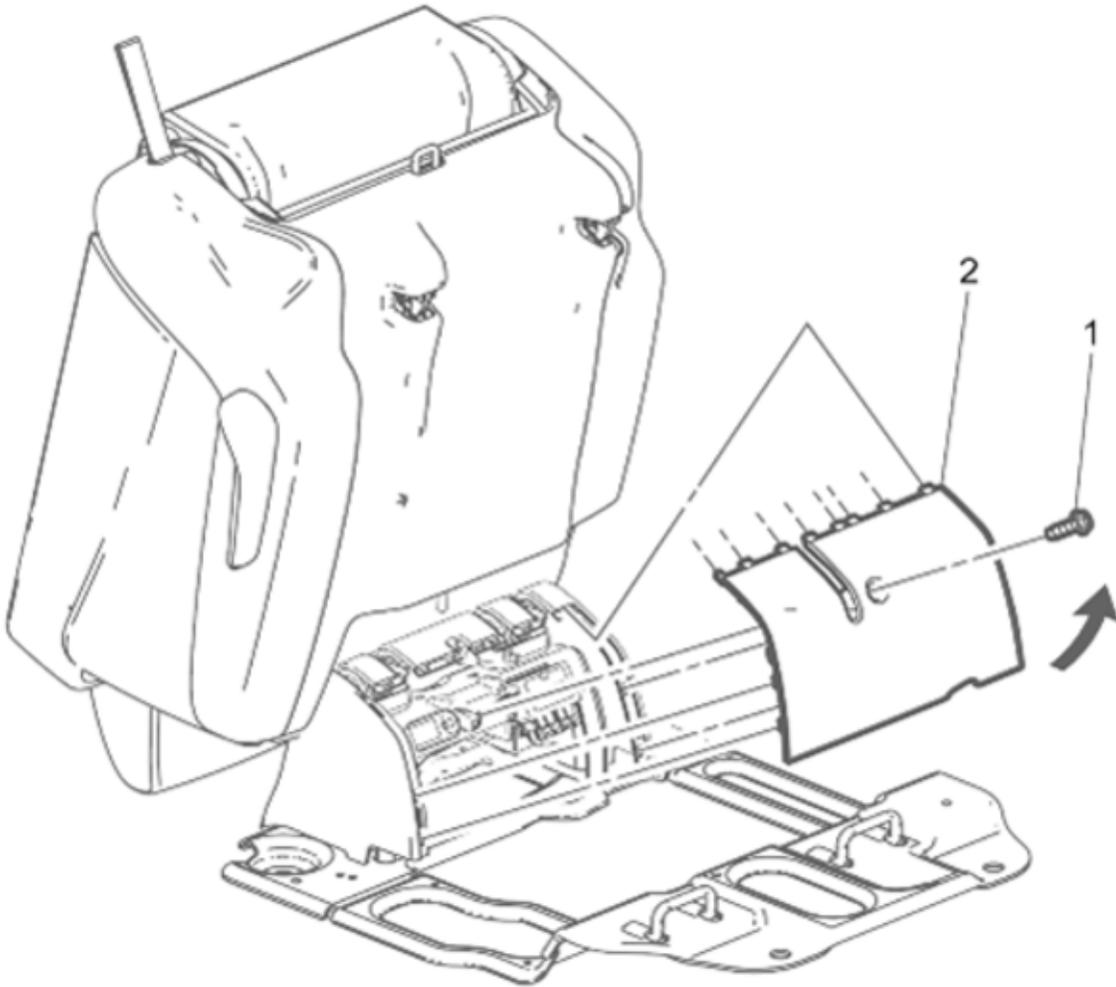

4.2 Inspect the seat base plate for contacting the ribs of the floor pan, as shown below. If contact is present paint damage can normally be seen at the area of contact.

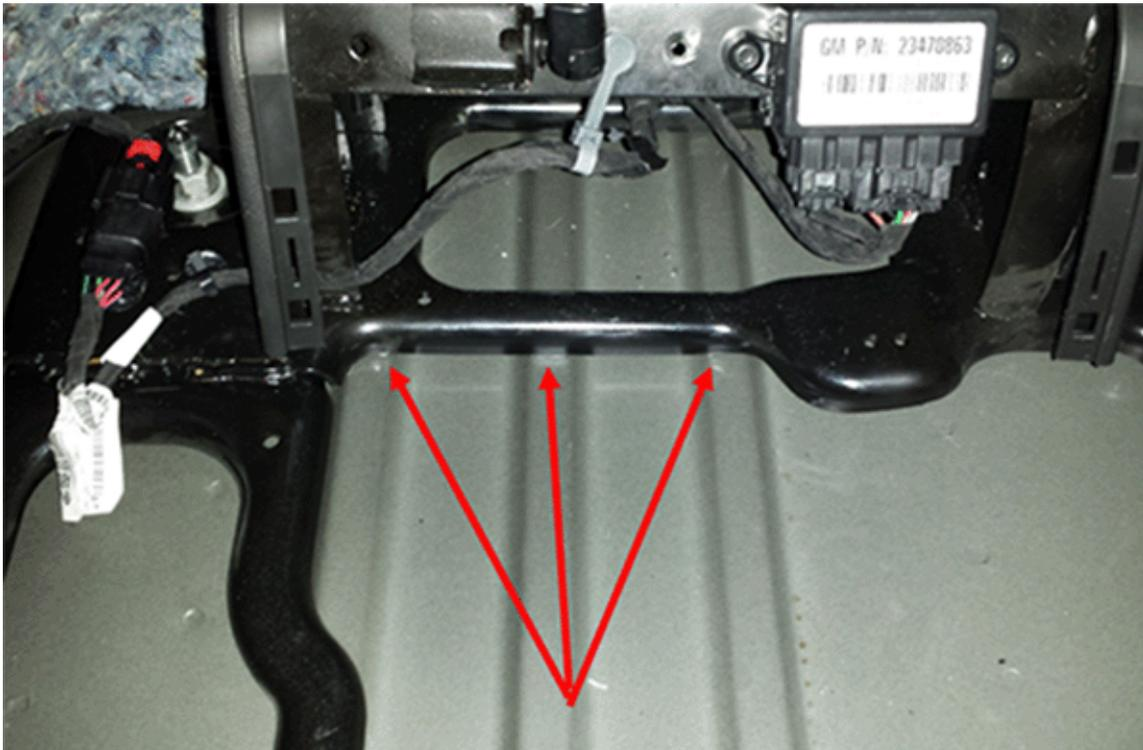

4.3. Remove the seat assembly and using the appropriate tools (example wood 2x4 and hammer) contoured the floor pan slightly to create clearance between

the seat base plate to floor pan.

4.4 Reinstall the seat and nuts. Tighten the nuts to 45 Nm (33 lb ft).

4.5 Inspect for clearance.

## Parts Information

| Part Number | Description | QTY     |
|-------------|-------------|---------|
| 11562546    | Washer      | As Req. |

## Warranty Information

For vehicles repaired under warranty use:

| Labor Operation | Description   | Labor Time |
|-----------------|---|------------|
| 7080218*        | Seat Latch Inspection   | 0.2 hr     |
| Add             | (Repair 1) Adjust Striker To Center In Latch Opening.                 | 0.1 hr     |
| Add             | (Repair 2) "forcefully" Slam The Seat Down Into The Latched Position. | 0.1 hr     |
| Add             | (Repair 3) Adjust Inboard to Outboard Striker Height Variations.      | 0.3 hr     |
| Add             | (Repair 4) Contour The Floor Pan Slightly To Create Clearance         | 0.2 hr     |

\* This is a unique labor operation for bulletin use only. This number will not be published in the Labor Time Guide.

Please follow this diagnostic or repair process thoroughly and complete each step. If the condition exhibited is resolved without completing every step, the remaining steps do not need to be performed.

GM bulletins are intended for use by professional technicians, NOT a "do-it-yourselfer". They are written to inform these technicians of conditions that may occur on some vehicles, or to provide information that could assist in the proper service of a vehicle. Properly trained technicians have the equipment, tools, safety instructions, and know-how to do a job properly and safely. If a condition is described, DO NOT assume that the bulletin applies to your vehicle, or that your vehicle will have that condition. See your GM dealer for information on whether your vehicle may benefit from the information.



WE SUPPORT VOLUNTARY TECHNICIAN CERTIFICATION