

**March 5, 2016**

03374 Version 1

## Product Update: Roof Molding

### AFFECTED VEHICLES

Year	Model	Trim	VIN Range
2016	Pilot	LX, EX, EX-L	Check the iN VIN status for eligibility

### BACKGROUND

Certain units have roof molding retaining clips that are spread too far apart. In high crosswinds, there is a possibility that the molding may detach.

### CUSTOMER NOTIFICATION

Owners of affected vehicles will receive a notification of this campaign.

Do an iN VIN status inquiry to make sure the vehicle is shown as eligible.

Some vehicles affected by this campaign may be in your new or used vehicle inventory. Repair these vehicles before they are sold.

### CORRECTIVE ACTION

Replace the existing roof molding clips and add additional clips.

### PARTS INFORMATION

Part Name	Part Number	Quantity
Roof Molding Kit	74306-TG7-315	1

### WARRANTY CLAIM INFORMATION

Operation Number	Description	Flat Rate Time	Defect Code	Symptom Code	Template ID	Failed Part Number
8141R7	Replace the roof molding clips and add new ones.	0.5 hr	6RM00	JY500	16-021A	91501-TG7-A01

**CUSTOMER INFORMATION:** The information in this bulletin is intended for use only by skilled technicians who have the proper tools, equipment, and training to correctly and safely maintain your vehicle. These procedures should not be attempted by "do-it-yourselfers," and you should not assume this bulletin applies to your vehicle, or that your vehicle has the condition described. To determine whether this information applies, contact an authorized Honda automobile dealer.

## REPAIR PROCEDURE

NOTE: If the vehicle has accessory roof rails installed, the vehicle is OK. Do not replace the clips.

### 1. Remove the driver's side roof molding.

- Starting at the back of the vehicle, place your hand over the rear tailgate hinge cover and gently lift in the area shown until the roof molding tongue is free from the rear tailgate hinge cover.

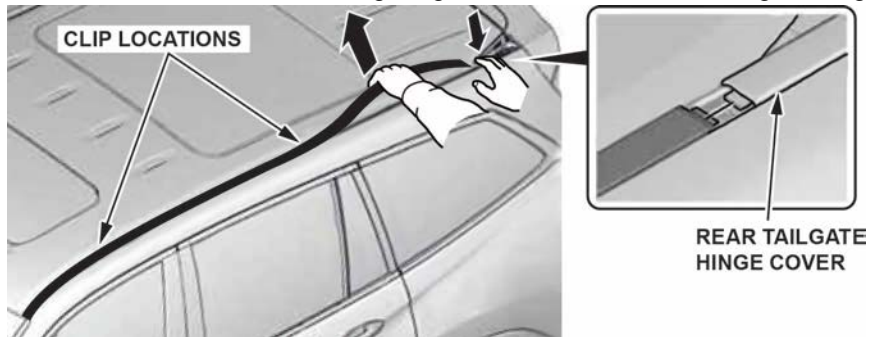

- Slide the rear of the molding out of the tailgate hinge cover.
- Moving towards the front, gently pull up on the molding to detach the two clips.
- Leave the molding attached to the front cap and place the molding towards the middle part of the roof to give yourself room to work.

NOTE: Be careful to not damage the molding or the vehicle's paint. Use a shop towel or similar item to protect the roof from being scratched.

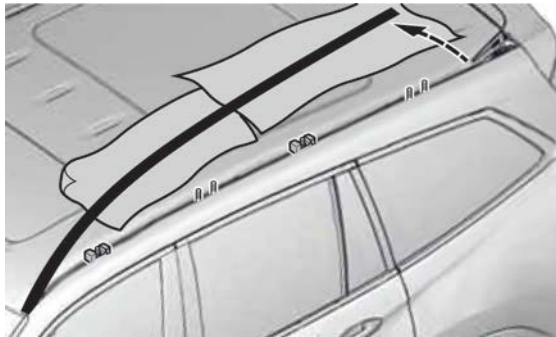

### 2. Remove the original clips from the roof.

Replace existing M6 clips (natural color).

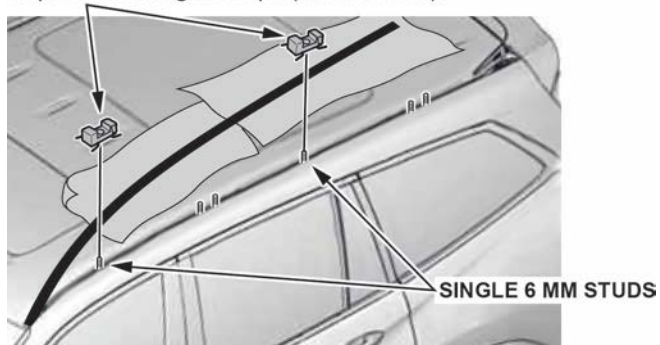

### 3. Install the two M6 clips (natural color) in the same location as the the original clips (the single 6 mm studs).

4. Install the front M8 roof clip (yellow color) on the first stud of the double 8 mm stud as shown, then install the second M8 roof clip on the second double 8 mm stud.

NOTE: Make sure the clips are installed facing the correct direction.

**FORWARD DOUBLE STUDS**

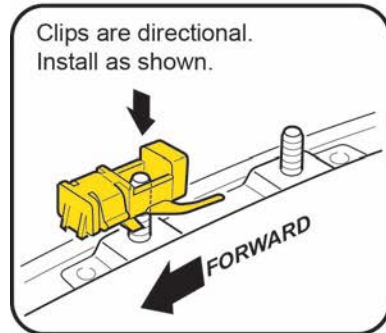

Add two M8 clips (yellow).

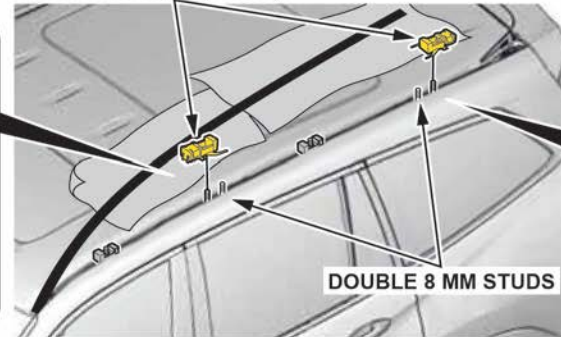

**REAR DOUBLE STUDS**

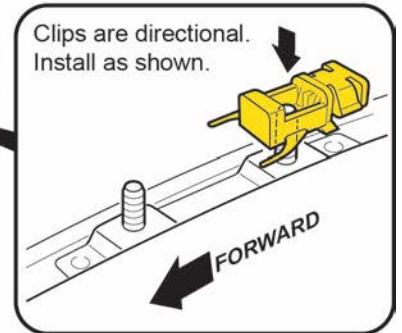

5. Reinstall the roof molding.

- Set the roof molding tongue in the rear tailgate hinge cover.
- Press the molding firmly at each clip location to make sure the clips are fully set.
- Make sure the molding is firmly pressed into the front cap. There should be no gap.

NOTE: A gap between the molding and the tailgate hinge cover is normal; it is needed for heat expansion.

6. Repeat steps 1 thru 5 for the other side.

END