



**Tiffin Motorhomes, Inc.
105 2nd Street NW
Red Bay, AL 35582
256-356-8661**

**SB-51
Magnum Inverters on 2016 Allegro Buses**

January 20, 2016

Dear Tiffin Customer,

It has come to our attention that some 2016 Allegro Bus Motorhomes could possibly have an inverter installed that was manufactured incorrectly. The manufacturer of the Magnum MS2812 inverter informed Tiffin Motorhomes there is a possibility that the suspect inverters received an internal component that was meant for another model inverter. Use of this component in the inverter will lead to premature failure of the inverter. The suspect inverters fall in a serial number range starting with **H1-34600** and ending with **H1-34830**. Tiffin Motorhomes has determined that your motorhome identified by the VIN listed above has an inverter that falls within range of these serial numbers.

We have included instructions on inspecting the inverter installed on your motorhome and what to do if the inverter has an incorrect FET printed circuit board. Sensata Technologies, the manufacturer of Magnum products, will be coordinating the inspections and repairs if needed. Their phone number is 425-353-8833.

If you have any questions about this notice, please contact the Tiffin warranty department at 256-356-8661 extension 2176 or email jeannie.madden@tiffinmotorhomes.com

We regret any inconvenience this action may cause, but feel certain you understand our interest in the continued use and enjoyment of your motorhome.

Thank you,

Tiffin Motorhomes, Inc.

SERVICE BULLETIN Number: 151216

The purpose of this bulletin is to inform RV OEMs/Dealers about the need to inspect, and if necessary, repair or replace the Magnum inverter.

Date Released: December 16, 2015

Reference: Magnum inverter/charger model **MS2812** within a serial number range starting with **H1-34600** and ending with **H1-34830** may be impacted.

Condition: Circuitry inside certain Magnum inverter/chargers may fail due to an incorrect FET Printed Circuit Board (i.e., FET Board) that may have been installed.

Inspection: Follow the steps below to inspect the Magnum inverter. If the inspection procedures determine an incorrectly installed FET board, the inverter must be removed and repaired, or replaced.

1. Open the motor home's electrical compartment containing the Magnum inverter.
2. View the model and serial number label on the side of the inverter (see Figure 1).

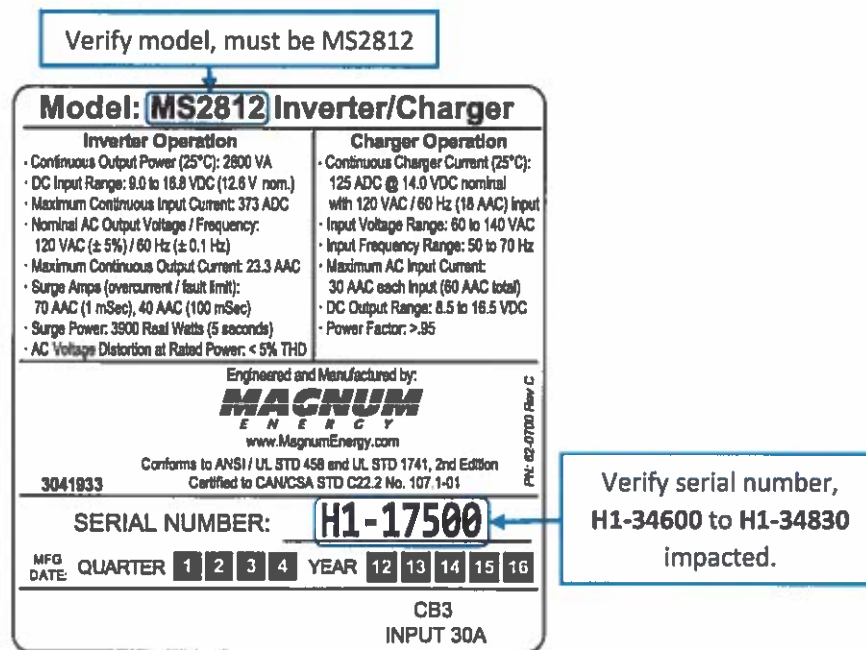

Figure 1, MS2812 Model/Serial Number label

3. If the serial number **is not** within the serial number range, the internal FET board is correct and no further inspection is required.
4. If the serial number **is** within the serial number range, the part number on the FET board inside the inverter will need to be viewed to verify if it is the correct part.

5. Attempt to verify whether the FET board is part 30-0041A (correct) or 30-0042 (remove).
 - This can be done with the top cover on (as shown in Figure 2). Simply look through the front right air intake grill (opposite side of serial number label side), and using a flashlight confirm the PCB revision.



Figure 2, Looking at FET Board thru grill

- If this is not possible-as the number cannot be observed or is covered-it will be necessary to remove the inverter's top cover (see Figure 3).

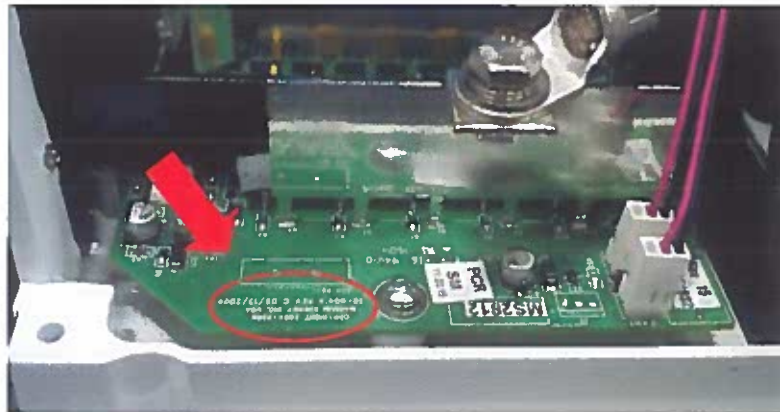
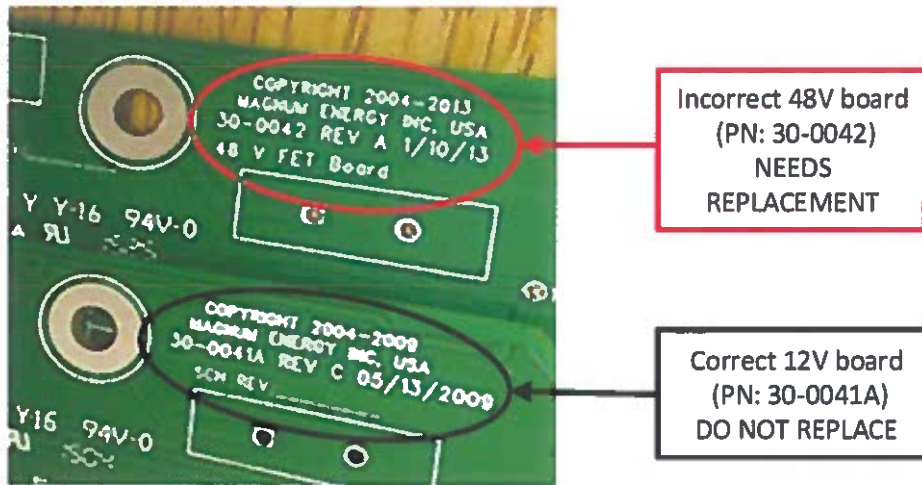

Figure 3, Looking at FET Board with top cover removed

6. After determining the part number of the FET board, document this information and provide it to Sensata's Technical Support team for Magnum products at 1-425-353-8833 (8AM to 5PM PST Monday – Friday). If you have an inverter with a FET board that needs to be replaced, they will assist you in locating an Authorized Service Center (ASC) in your area, or will exchange the inverter.

Understand there are two different board-stenciled part numbers:

- 30-0041A board is for 12-volt inverters - correct and does not need to be replaced.
- 30-0042 board is only for 48-volt inverters - incorrect and **NEEDS REPLACEMENT**.



Documentation:

MS2812 Serial Number: _____
 Confirmed FET Board Part Number: _____
 Motor Home VIN: _____
 RMA (If inverter replacement required): _____

Warranty Labor Allowance: If replacement of the MS2812 inverter/charger is required, Sensata allows 30 minutes for product inspection, and one hour of labor for product removal / re-installation.

Inverter inspection: 0.5 hrs.
 Removal/Reinstall inverter: 1.0 hrs.

*If you have any questions concerning this bulletin, contact Magnum Technical Support at:
 1-425-353-8833*

Summary of UL Testing and Compliance related to safety & Thermal performance

- I. Inverters for mobile applications are tested to UL458, the standard for mobile power converters and inverters. This standard covers the design, construction and performance verification of mobile power inverters. The purpose of this standard is to ensure end products are safe and reliable through compliance with the standard as demonstrated by testing and follow-up audits conducted by ETL.

The report contains construction information, critical components and performance test compliance.

- II. **Electrical Safety**

- a. Section 28 Spacings specifies minimum distances as required to maintain dielectric separation between live circuits. For 120 V circuits, 1/8" through air and ¼" over surfaces. PWBs may have reduced spacings per UL840.
- b. Section 3.1 Components – components used in this product shall comply with the requirements for said component. Line connected components and any component providing dielectric separation are UL Recognized for their application. Recognition marks are plainly visible on those components.

- III. **Flammability**

- a. Section 6.4 (Construction) A polymeric part of an enclosure shall comply with the requirements of the Standard for Polymeric Materials – Use in Electrical Equipment Evaluations, UL746C. UL746, section 4, table 1 states minimum material requirements for enclosure elements.
- b. Section 27 Printed Wiring: A printed wiring board shall comply with the standard for Printed Wiring Boards, UL796. UL796 Section 21 refers to Flammability testing and the requirement of flammability classification. Boards used by Sensata/Magnum-Dimensions are fabricated by Parason Industries (Yan Tat Technology Co), UL file #E152990, types Y-16 and Y-01; type Y-01 meets UL796 DSR for line voltage application. Both types comply with UL94 V0 flammability test. Board type & UL compliance is marked directly on every board by the fabricator.

- IV. **Electrical Tests – carried out on a sample of the inverter and passed as requirement to approval under the Standard:**

- a. Section 36, maximum current: to verify the maximum input current under continuous conditions, as specified on the nameplate.
- b. Section 37.1 Normal Temperature Test: verify internal components do not exceed their rated temperature (as specified in the Standard) while under rated load. Of significance are the transformer (200 C rated insulation system; maximum internal temperature of 165 C as measured by thermocouple) and semiconductors (100 C). The unit is tested in various mounting positions to verify continuous operation
- c. Section 37.2 Maximum Output without Fan: carried out as with 37.1, but with a reduced load so as the fan is not operated.
- d. Section 37.4 Maximum Overload without Trip: the unit is operated at a load below the level which any internal protective device (other than a branch-rated breaker) operates. Required branch-rated breakers are to be bypassed during this test. No internal component may exceed 20 C above temperatures permitted in 37.1

- e. Section 38 External Surface Temperature Limits: Metallic surfaces subject to casual contact may not exceed 70 C during normal operation.
 - f. Section 39 Dielectric Withstand: withstand for 1 minute 1000V + 2x rated voltage as a 60 Hz rms potential applied between the primary (AC) circuit and any dead metal (chassis) or secondary.
 - g. Section 46 Battery Charger Overcharge: Verify unit is able to withstand 106% of rated input voltage during charging, adjusted to supply the most possible charge current.
 - h. Section 47 Abnormal Tests: For any of the following tests, the unit must not emit flame or molten metal or become a risk of fire, electric shock or injury to persons. This includes insulation breakdown and live parts becoming accessible. Tests are to be repeated until a final condition is met, such as shorting or opening internal components, operation of a branch circuit breaker, or opening of an internal fuse. Manual or Automatic protectors must actuate within 2 minutes of test initiation and within 30 seconds of subsequent tests.
 - i. 47.2 Output Short Circuit – The output of the unit is to be short circuited.
 - ii. 47.4 Component Malfunction – Individual components within the unit are to be opened or short-circuited. Switching is to occur during normal operation.
 - iii. 47.6 Vibration Test – the unit shall be operable and with no loosening of parts after 1 hour of 12.5 Hz ¼” peak-to-peak displacement in the vertical plane.
 - iv. 47.8 Specific Value Overload – The unit is to be operated at 200% rated load connected to the output. A manual reset protector is to be operated for 50 cycles.
 - v. 47.11 Blocked Fan Test – A unit shall be operated for 7 hours with the rotor of the fan motor prevented from rotating
 - i. Section 49.3 Transformer Burnout: The internal transformer shall be operated with a load set to draw 3x the rated current (bypassing protective devices). The unit is to be operated until ultimate conditions occur or cycled 50 times if a manual reset protector operates.
- V. Production Tests:
- a. Section 53 Dielectric Withstand: A test potential of 1200 VAC (or 1700 VDC) is applied for 1 second between primary terminals and both dead metal parts and secondary wiring.
 - b. Section 54 Grounding Continuity Test: A continuity test is to be performed between the dead metal of the chassis and any external grounding means.