

**WF89 - Replacing Coolant Regulator (Workshop Campaign)**

Vehicle type: **Cayenne S Hybrid (92A)**

Model Year: **2011**

Country/Market:

- USA (C02)
- Canada (C36)
- Korea (C39)

Subject: **Coolant regulator**

Issue: **A coolant regulator that does not meet the high Porsche quality standards may have been installed in the affected vehicles.**

The function of the coolant regulator can therefore be impaired over the service life of the vehicle and as a result, the red warning "Coolant temperature too high" can be displayed in the instrument cluster.

Remedial action: Replace coolant regulator.

Affected Vehicles: Only the vehicles assigned to the campaign (see also PIWIS Vehicle information).

Parts Info: **NOTE: PARTS FOR THIS CAMPAIGN WILL BE AUTOMATICALLY ALLOCATED FOR UP TO 80% OF THE VEHICLES THAT ARE SERVICED AT YOUR DEALERSHIP. ONCE YOUR DEALERSHIP IS OUT OF STOCK AND REQUIRES ADDITIONAL PARTS, PLEASE SUBMIT A PTEC/PAV.**

Part No.	Designation - Use	Qty.
000 043 303 59	⇒ Thermostat housing with coolant regulator	1 ea.
000 043 303 53	⇒ Sealing ring - Front centre coolant pipe	1 ea.
000 043 303 54	⇒ Sealing ring - Front coolant pipe, left and right	2 ea.
000 043 303 56	⇒ Seal - Intake manifold, top	6 ea.
000 043 303 52	⇒ Breather pipe - Crankcase to compressor	1 ea.

Materials: 000 043 305 16 Antifreeze 20-litre container  
(approx. 1.5 litres required per vehicle)

Tools:

- **T10060 A - Staking mandrel**
- Spring band clamp pliers., e.g **VAS 6890 - Spring band clamp pliers** and **VAS 6891 - Spring band clamp pliers**
- Hose clamps, up to 25 mm, e.g. **3094 - Hose clamp** (2 ea.)
- **9696 - Filling device**
- Torque wrench, 2 - 10 Nm (1.5 - 7.5 ftlb.), e.g. **V.A.G 1783 - Torque wrench, 2-10 Nm (1.5-7.5 ftlb.)**
- Torque wrench, 6 - 50 Nm (4.5 - 37 ftlb.), e.g. **V.A.G 1331 - Torque wrench, 6-50 Nm (4.5-37 ftlb.)**
- Open-jawed insert, a/f 17 for torque wrench
- Drip tray

Procedure: 1 Remove engine guard ⇒ *Workshop Manual '108019 Removing and installing engine guard'*.

 **WARNING**

**Hot fluid**

- **Danger of scalding**
- ⇒ **Let the fluid cool down.**
- ⇒ **Wear personal protective gear.**

- 2 Drain coolant for high-temperature cooling system ⇒ *Workshop Manual '193817 Draining and filling coolant (includes bleeding)'*.
- 3 Remove the engine cover.
- 4 Remove engine compartment trim panel at the right ⇒ *Workshop Manual '700219 Removing and installing front trim panel (engine compartment)'*.
- 5 Remove drive belt for compressor ⇒ *Workshop Manual '137819 Removing and installing drive belt'*.
- 6 Disconnect the battery ⇒ *Workshop Manual '978509 Loosening and securing ground strap for battery'*.

 **WARNING**

**Hot fluid**

- **Danger of scalding**
- ⇒ **Let the fluid cool down.**

⇒ **Wear personal protective gear.**

7 Remove compressor ⇒ *Workshop Manual '211419 Removing and installing compressor (Hybrid)'*.

8 Disconnect front left coolant pipes.

8.1 Loosen vacuum pipe from the holder ⇒ *Front left coolant pipes -1-* and unscrew and remove fastening screw ⇒ *Front left coolant pipes -2-*.

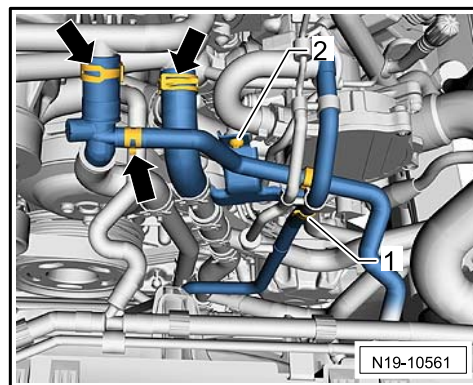

*Front left coolant pipes*

8.2 Unscrew and remove fastening screws ⇒ *Screws for coolant pipes for low-temperature system -1 and 2-* for coolant pipes for low-temperature system.

8.3 To make it easier to reach the outer left fastening screw ⇒ *Screws for coolant pipes for low-temperature system -3-*, loosen the additional coolant pump at the holder if necessary.

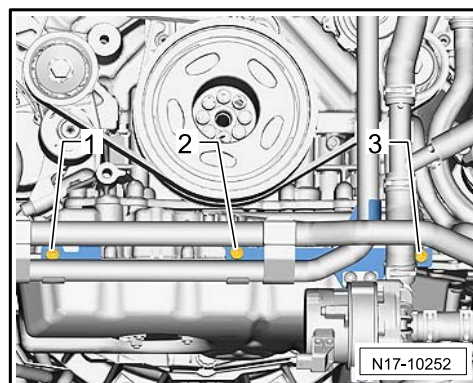

*Screws for coolant pipes for low-temperature system*

To do this, loosen the top fastening screws and unscrew and remove the bottom fastening screw ⇒ *Additional coolant pump -arrows-*.

The electric plug connection ⇒ *Additional coolant pump -1-* and coolant hoses ⇒ *Additional coolant pump -2-* remain connected to the additional coolant pump.

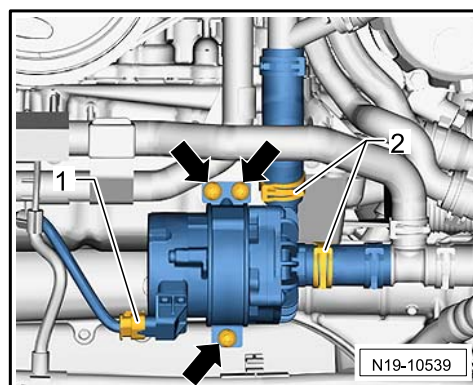

*Additional coolant pump*

**⚠ WARNING****Hot fluid**

- **Danger of scalding**
- ⇒ **Let the fluid cool down.**
- ⇒ **Wear personal protective gear.**

- 9 Remove front coolant pipe ⇒ *Front coolant pipe.*

**Overview**

**Blue** – Front coolant pipe

**1** – Hose clamp

**2** – Coolant temperature sensor

**3** – Screw securing coolant pipe to coolant regulator

**Arrows** – Fastening screws for front coolant pipe

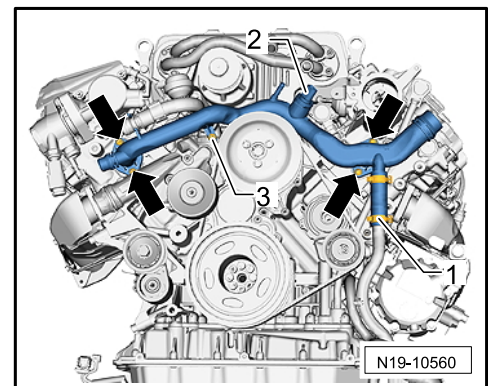

*Front coolant pipe*

- 9.1 Remove coolant hose from the front coolant pipe.  
To do this, release the retaining clip ⇒ *Coolant hose on front coolant pipe -arrow-* and pull the coolant hose off the coolant pipe. Then push the retaining clip in again.

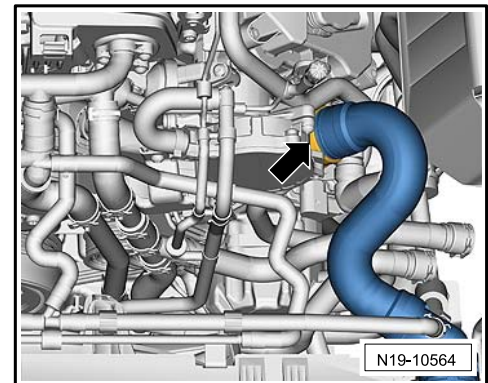

*Coolant hose on front coolant pipe*

- 9.2 Disconnect electric plug connection at the coolant pump valve ⇒ *Coolant pump valve -1-*.
- 9.3 Press the locking mechanism ⇒ *Coolant pump valve -arrows-* together and pull coolant pump valve ⇒ *Coolant pump valve -1-* off the front coolant pipe ⇒ *Coolant pump valve -arrow-*.



### Information

Due to restricted access to the locking mechanism, an alternative approach would be to disconnect the vacuum lines at the coolant pump valve. The valve can remain on the coolant pipe. In this case, mark the position of the vacuum lines at the connections on the valve.

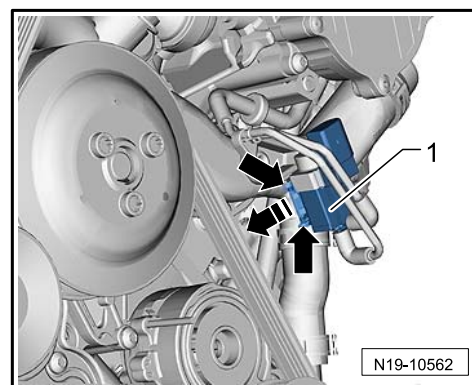

*Coolant pump valve*

- 9.4 Disconnect secondary-air hose ⇒ *Secondary-air hose and coolant hose -1-* and coolant hose ⇒ *Secondary-air hose and coolant hose -arrow-*.  
To do this, release the retaining clip on the coolant hose and pull the coolant hose off the coolant pipe.  
Then push the retaining clip in again.

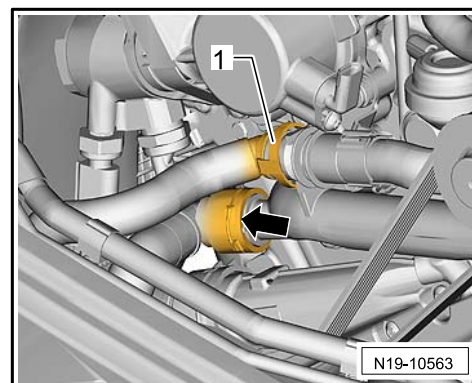

*Secondary-air hose and coolant hose*

- 9.5 Loosen hose clamp ⇒ *Front coolant pipe -1-* and disconnect electric plug connection ⇒ *Front coolant pipe -2-* on the coolant temperature sensor.
- 9.6 Unscrew and remove screw ⇒ *Front coolant pipe -3-* securing the coolant pipe to the coolant regulator.
- 9.7 Unscrew and remove fastening screws ⇒ *Front coolant pipe -arrows-* for the front coolant pipe.
- 9.8 Pull coolant pipe forward off the coolant regulator adapter. Then carefully press the coolant pipes you loosened earlier forward slightly, guide the coolant pipe out at the engine and pull it up to remove it.

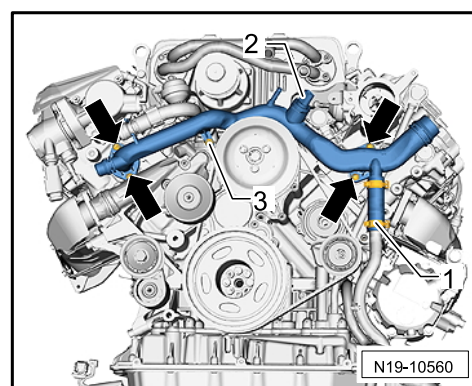

*Front coolant pipe*

- 10 Replace coolant regulator.
- 10.1 Unscrew and remove fastening screws ⇒ *Coolant regulator -arrows-* on the coolant regulator housing.
  - 10.2 Remove coolant regulator by pulling it up and dispose of it.
  - 10.3 Clean sealing face on the flange for the coolant regulator.
  - 10.4 Install new coolant regulator, Part No. 000 043 303 59, and tighten fastening screws.  
**Tightening torque 9 Nm (6.5ftlb.)**



Coolant regulator

- 11 Install front coolant pipe.
- 11.1 Clean sealing faces for the front coolant pipe on the engine.
  - 11.2 Replace sealing rings on the front coolant pipe. Coat the sealing rings with coolant and slide them onto the coolant pipe.
  - 11.3 Guide in the front coolant pipe at the engine and push it into the adapter on the coolant regulator and onto the adapter on the coolant pipe. Carefully press the coolant pipes that are routed vertically downwards ahead of the coolant pipe forward slightly if necessary.
  - 11.4 Screw in and tighten fastening screws ⇒ *Front coolant pipe -arrows-* for the front coolant pipe.  
**Tightening torque 10 Nm (7.5ftlb.)**
  - 11.5 Screw in and tighten screw ⇒ *Front coolant pipe -3-* securing the front coolant pipe to the coolant regulator.
  - 11.6 Secure the coolant hose with the hose clamp ⇒ *Front coolant pipe -1-* and connect electric plug connection on the coolant temperature sensor ⇒ *Front coolant pipe -2-*.

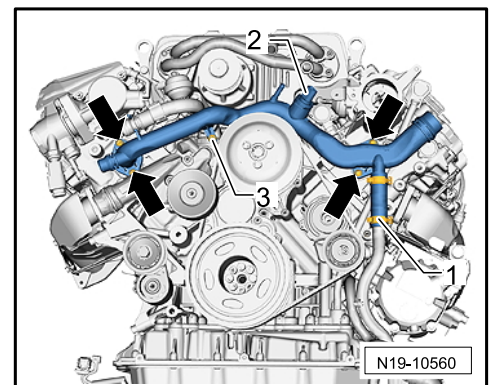

Front coolant pipe

11.7 Connect secondary-air hose ⇒ *Secondary-air hose and coolant hose -1-* and coolant hose ⇒ *Secondary-air hose and coolant hose -arrow-* until they engage securely. Check that the hoses are secure by pulling on them.

11.8 Depending on the procedure used during removal, either push the component pump valve into the bracket on the coolant pipe until it engages securely or push the vacuum lines onto the connections on the coolant pump valve.

11.9 Connect electric plug connection at the coolant pump valve ⇒ *Coolant pump valve -1-*.

11.10 Connect coolant hose to the front coolant pipe ⇒ *Coolant hose on front coolant pipe -arrow-* until it engages securely. Check that the coolant hose is secure by pulling on it.

12 Secure front left coolant pipes.

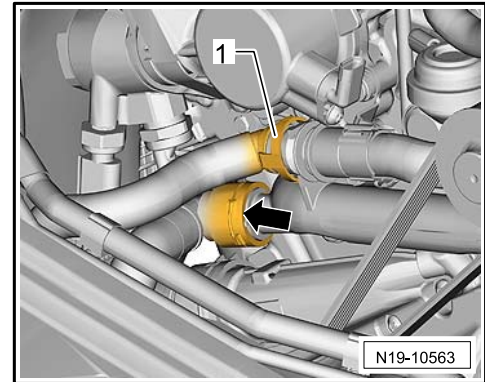

*Secondary-air hose and coolant hose*

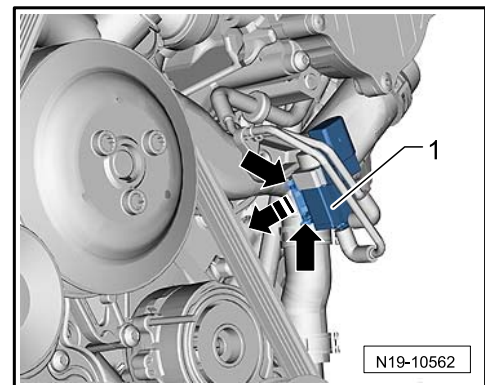

*Coolant pump valve*

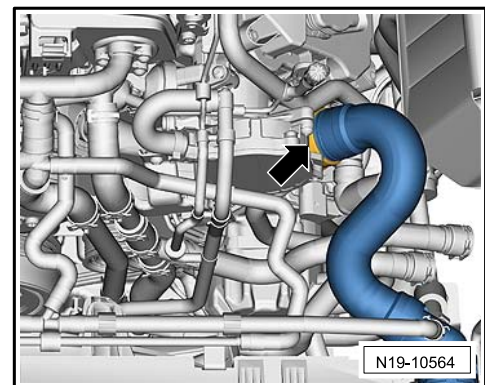

*Coolant hose on front coolant pipe*

- 12.1 Screw in and tighten fastening screws ⇒ *Screws for coolant pipes for low-temperature system -1 to 3-* for coolant pipes for low-temperature system.  
**Tightening torque 10 Nm (7.5 ftlb.)**

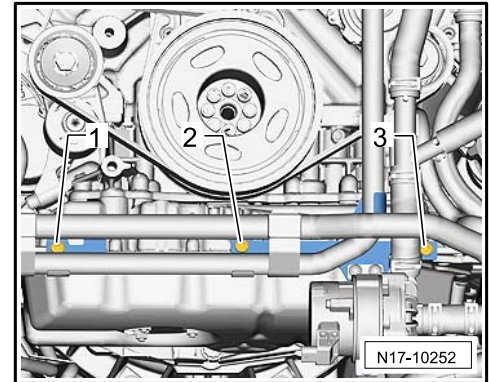

*Screws for coolant pipes for low-temperature system*

- 12.2 If loosened earlier, secure the additional coolant pump to the holder ⇒ *Additional coolant pump -arrows-*.  
**Tightening torque 10 Nm (7.5 ftlb.)**

- 13 Install compressor ⇒ *Workshop Manual '211419 Removing and installing compressor (Hybrid)'*.

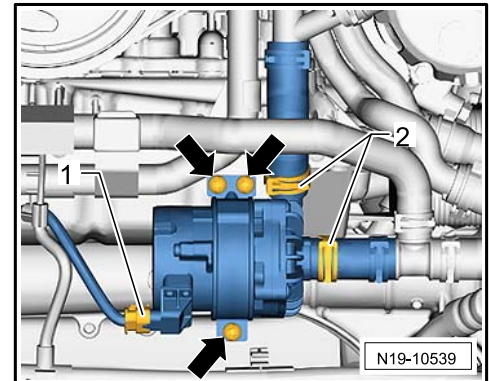

*Additional coolant pump*

- 14 Press vacuum pipe into the holder ⇒ *Front left coolant pipes -1-* and screw in and tighten fastening screw ⇒ *Front left coolant pipes -2-*.  
**Tightening torque 10 Nm (7.5 ftlb.)**

- 15 Install drive belt for compressor ⇒ *Workshop Manual '137819 Removing and installing drive belt'*.

- 16 Fill and bleed the cooling system ⇒ *Workshop Manual '193817 Draining and filling coolant (includes bleeding)'*.

- 17 Install engine compartment trim panel at the right ⇒ *Workshop Manual '700219 Removing and installing front trim panel (engine compartment)'*.

- 18 Install the engine cover.

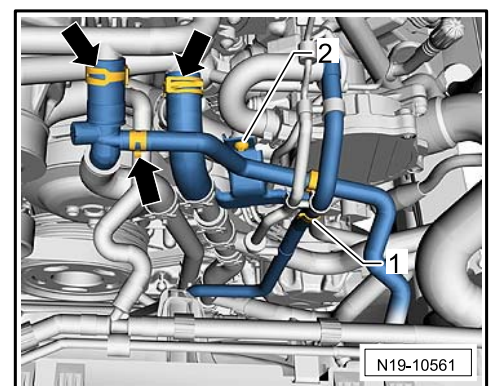

*Front left coolant pipes*

- 19 Connect the battery and perform work instructions after disconnecting the battery ⇒ *Workshop Manual '978509 Loosening and securing ground strap for battery'* and ⇒ *Workshop Manual '2X00IN Work instructions after disconnecting the battery'*.
- 20 Install engine guard ⇒ *Workshop Manual '108019 Removing and installing engine guard'*.
- 21 Enter the campaign in the Warranty and Maintenance booklet.

- References:
- ⇒ *Workshop Manual '1001IN Tightening torques, tightening sequences, assembly overviews'*
  - ⇒ *Workshop Manual '108019 Removing and installing engine guard'*
  - ⇒ *Workshop Manual '137819 Removing and installing drive belt'*
  - ⇒ *Workshop Manual '193817 Draining and filling coolant (includes bleeding)'*
  - ⇒ *Workshop Manual '195819 Removing and installing coolant regulator (thermostat)'*
  - ⇒ *Workshop Manual '196120 Removing and installing coolant pipes'*
  - ⇒ *Workshop Manual '2X00IN Work instructions after disconnecting the battery'*
  - ⇒ *Workshop Manual '211419 Removing and installing compressor (Hybrid)'*
  - ⇒ *Workshop Manual '700219 Removing and installing front trim panel (engine compartment)'*
  - ⇒ *Workshop Manual '978509 Loosening and securing ground strap for battery'*

**Warranty Invoicing**



**Information**

The specified working time was determined specifically for carrying out this campaign and includes all necessary preliminary and subsequent work.  
 The working time may differ from the working times published in the Labour Operation List in PIWIS.

Scope 1:

**Cayenne S Hybrid**

**Working time:**

Replacing coolant regulator

Labor time: **349 TU**

Includes:

- Removing and installing engine guard
- Draining and filling coolant
- Removing and installing engine cover
- Removing and installing engine compartment trim panel at the right
- Removing and installing drive belt for compressor
- Loosening and securing ground strap for battery
- Removing and installing compressor
- Loosening and securing front left coolant pipes
- Removing and installing front coolant pipe

**Parts required:**

000 043 303 59	Thermostat housing	1 ea.
000 043 303 53	Sealing ring	1 ea.
000 043 303 54	Sealing ring	2 ea.
000 043 303 56	Seal	6 ea.
000 043 303 52	Breather pipe	1 ea.
<b>Additional materials required:</b>		
000 043 305 16	Antifreeze, 20-litre container	0.08 ea. (= approx. 1.5 litres)

**Warranty Invoicing: ⇒ Damage Code WF89 66 000, Repair Code 2**

**Important Notice:** Technical Bulletins issued by Porsche Cars North America, Inc. are intended only for use by professional automotive technicians who have attended Porsche service training courses. They are written to inform those technicians of conditions that may occur on some Porsche vehicles, or to provide information that could assist in the proper servicing of a vehicle. Porsche special tools may be necessary in order to perform certain operations identified in these bulletins. Use of tools and procedures other than those Porsche recommends in these bulletins may be detrimental to the safe operation of your vehicle, and may endanger the people working on it. Properly trained Porsche technicians have the equipment, tools, safety instructions, and know-how to do the job properly and safely. If a particular condition is described, do not assume that the bulletin applies to your vehicle, or that your vehicle will have that condition. See your authorized Porsche Dealer for the latest information about whether a particular technical bulletin applies to your vehicle. Part numbers listed in these bulletins are for reference only. Always check with your authorized Porsche dealer to verify the current and correct part numbers. The work procedures updated electronically in the Porsche PIWIS diagnostic and testing device take precedence and, in the event of a discrepancy, the work procedures in the PIWIS Tester are the ones that must be followed.

© Porsche Cars North America, Inc.

Dealership	Service Manager	Shop Foreman	Service Technician
Distribution	Asst. Manager	Warranty Admin.	Service Technician
Routing			

Dr. Ing. h.c. F. Porsche AG is the owner of numerous trademarks, both registered and unregistered, including without limitation the Porsche Crest®, Porsche®, Boxster®, Carrera®, Cayenne®, Cayman®, Macan®, Panamera®, Speedster®, Spyder®, 918 Spyder®, Tiptronic®, VarioCam®, PCM®, PDK®, 911®, RS®, 4S®, FOUR, UNCOMPROMISED®, and the model numbers and the distinctive shapes of the Porsche automobiles such as, the federally registered 911 and Boxster automobiles. The third party trademarks contained herein are the properties of their respective owners. Porsche Cars North America, Inc. believes the specifications to be correct at the time of printing. Specifications, performance standards, standard equipment, options, and other elements shown are subject to change without notice. Some options may be unavailable when a car is built. Some vehicles may be shown with non-U.S. equipment. The information contained herein is for internal authorized Porsche dealer use only and cannot be copied or distributed. Porsche recommends seat belt usage and observance of traffic laws at all times.

Printed in the USA