

Suspension Bushings Leaking

Vehicle Type: Sports Cars (9x1)

Model Year: 2012 - Present

Information: Suspension bushings appear to be leaking.

When suspension bushings are installed, an assembly lubricant is used. It is possible that over time this lube will weep and appear to be a leak from a bushing that is not hydraulic.



Verify that fluid is not leaking from other components such as shocks or struts and clean off the weeping lube.

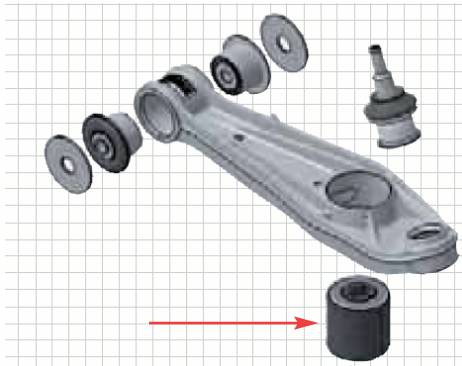

The only hydraulic bushing on the 9X1 vehicles is in the lower control arm of the front suspension.

Dealership	Service Manager _____	Service Specialist _____	_____	_____	_____	_____	_____	_____	_____
Distribution	Asst. Manager _____	Service Specialist _____	_____	_____	_____	_____	_____	_____	_____
Routing									

Dr. Ing. h.c. F. Porsche AG is the owner of numerous trademarks, both registered and unregistered, including without limitation the Porsche Crest®, Porsche®, Boxster®, Carrera®, Cayenne®, Cayman®, Macan®, Panamera®, Speedster®, Spyder®, 918 Spyder®, Tiptronic®, VarioCam®, PCM®, PDK®, 911®, RS®, 4S®, FOUR, UNCOMPROMISED®, and the model numbers and the distinctive shapes of the Porsche automobiles such as, the federally registered 911 and Boxster automobiles. The third party trademarks contained herein are the properties of their respective owners. Porsche Cars North America, Inc. believes the specifications to be correct at the time of printing. Specifications, performance standards, standard equipment, options, and other elements shown are subject to change without notice. Some options may be unavailable when a car is built. Some vehicles may be shown with non-U.S. equipment. The information contained herein is for internal authorized Porsche dealer use only and cannot be copied or distributed. Porsche recommends seat belt usage and observance of traffic laws at all times.