

FLA COE
FLB COE
FLD Conventional
Business Class
FLC 112 Conventional

> Century Class Conventional
> Argosy COE
Cargo
> Columbia

> 122SD and Coronado
> Business Class M2
> Cascadia
> 108SD/114SD

Freightliner
Service Bulletin

Description of Revisions: *This bulletin replaces the version dated July 2015. In Check 9, partial and wide open throttle have been used instead of 1500 and 2000 RPM because of variations in operating RPM by engine application. Starter troubleshooting has been updated to clarify model-based variations in the procedure.*

Using the Powernet Assessment Worksheet

For all battery, charging, or starting issues:

1. Print out the "Powernet Assessment Worksheet," found at the end of this bulletin.
2. Use the "Powernet Assessment Detail Section" to understand and master the worksheet. The detail section, starting on page 2, breaks the worksheet down step by step.
3. Perform each line of the worksheet in order, recording the initial value of each check before performing repairs. Repair issues as they are found, then recheck. Complete the entire worksheet even if the original issue seems to be resolved.
4. Once all the checks in the "Powernet Assessment Worksheet" have been completed, if a starting issue persists, use the "Troubleshooting the Starting System" section near the end of this bulletin.

EPA10/EPA04 and EPA07 Vehicles Require Different Starter Path Voltage Drop Checks

Two different starter path voltage drop checks are included in the worksheet: an EPA10/EPA04 Check 5, and an EPA07 Check 5. The alternator cables route through the starter on all vehicles except EPA07, so EPA07 vehicles have a different starter path voltage drop procedure.

NOTE: EPA07 vehicles with jump start posts connected to the starter can be tested using the non-EPA07 (EPA10, EPA04) vehicle procedure by placing the carbon pile clamps on the jump posts instead of the alternator in check 5a and 5b. Using the jump posts will include them and their cables to the starter in the voltage drop check.

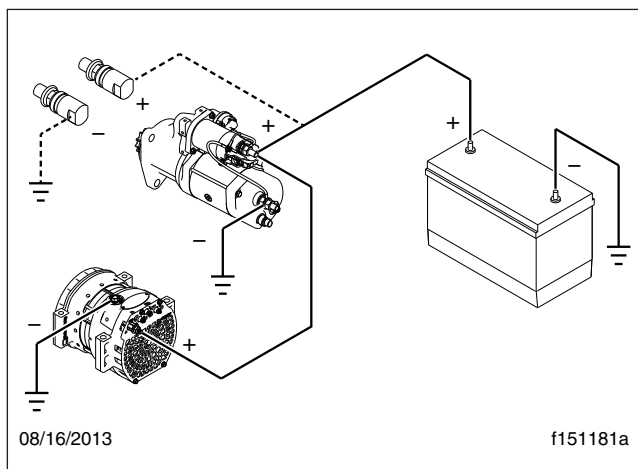

Fig. 1, EPA04, and EPA10 and newer: the alternator routes through the starter. Use "Starter Path Check — EPA10, EPA04 Engines" for Check 5.

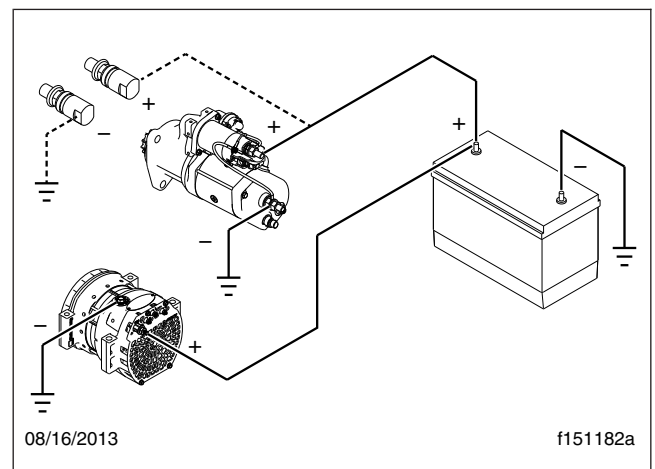

Fig. 2, EPA07: the alternator does not route through the starter. Use "Starter Path Check — EPA07 Engines" for Check 5, unless the vehicle has jump posts.

Freightliner Service Bulletin

FLA COE
 FLB COE
 FLD Conventional
 Business Class
 FLC 112 Conventional

> Century Class Conventional
 > Argosy COE
 > Cargo
 > Columbia

> 122SD and Coronado
 > Business Class M2
 > Cascadia
 > 108SD/114SD

Powernet Worksheet Detail Section (Batteries, Path, Alternator)

BATTERIES CHECK	DMM (Digital Multimeter):	Rec Value	Accept Value
1. Check battery pack voltage to determine state of charge. Charge pack to 100%. If unable, go to 3, "Break pack."	POS and NEG batt pack.		12.8V AGM 12.6V Flood

Check 1 — Check battery pack voltage to determine state of charge.

If equipped, set Load Disconnect Switch to "Off." With the DMM probes on the positive and negative posts of the battery pack, record the voltage. Due to differences in their design and operation, flooded cell and AGM batteries have different voltages at the same state of charge.

Batteries should be fully charged before further testing. If batteries are not fully charged, they will draw current to recharge during testing, invalidating the troubleshooting test results. Fully charged batteries ensure reliable diagnosis.

See **Table 1** for voltage as an approximate indicator of state of charge (SoC) for AGM and flooded batteries.

If the battery pack will not charge to 100% state of charge, there may be a shorted cell. Break the pack into individual batteries and test individually using an approved tester. Go to **Check 3, Individual Battery Testing**. After batteries have been tested individually, verify pack voltage once again.

Flooded	AGM	SoC
12.6	12.8	100%
12.4	12.6	80%
12.3	12.4	60%
12.1	12.2	40%
12	12	20%
11.8	11.8	0%

Table 1, Voltage to Approximate State of Charge (SoC)

2. Remove surface charge: HVAC blower, lights on, 5 min.
--

Check 2 — Remove surface charge: HVAC blower, lights on, 5 min.

Surface charge refers to a higher initial charge (volts), when discharging, in recently-charged batteries. This charge is a "shallow" charge, meaning that the charging-induced chemical reaction has mostly occurred at the surface of the lead plates, and has not equalized throughout the lead. Drawing current from the batteries before testing removes the surface charge, allowing for a better assessment of the "deep charge" state of the lead plates.

After the surface charge is removed, the batteries need to be at least 80% SoC for further testing. See **Table 1** for voltage as an approximate indicator of state of charge.

FLA COE
 FLB COE
 FLD Conventional
 Business Class
 FLC 112 Conventional

> Century Class Conventional
 > Argosy COE
 > Cargo
 > Columbia

> 122SD and Coronado
 > Business Class M2
 > Cascadia
 > 108SD/114SD

**Freightliner
 Service Bulletin**

3. Break pack into individual batteries and test each with an approved battery tester. (Remove NEG cables first!) Replace batteries if instructed by the tester. All batteries must pass the battery tester evaluation before troubleshooting continues.	Batt 1: PASS or FAIL
	Batt 2: PASS or FAIL
	Batt 3: PASS or FAIL
	Batt 4: PASS or FAIL

Check 3 - Individual Battery Testing

Batteries should only be tested individually. If the battery pack had to be charged, let the pack rest a minimum of 1 hour before testing the batteries.

3.1 Remove the negative cables of the batteries first, and secure the leads out of the way before touching the positive cables. Remove the battery cables and clean the terminal pads with a wire brush. The tester clamps will not make sufficient contact with dirty or corroded contact pads.

3.2 Connect the battery tester's positive and negative clamps to the lead base terminal pads at the positive and negative studs. See **Fig. 3**.

The threaded portion of the battery posts are *not* the right place to clip: the steel threads won't make a good connection. The base of the post, on the lead, is the best place to clip. Taking a few extra seconds to make sure the tester, DMM, and carbon pile clips are well-connected can be the difference between a useful and a useless test.

NOTE: If the lead base is too small to clamp to, only lead stud adapters should be used, never nuts. The lead stud adapters must be screwed down tight against the cleaned lead base using a hand tool. Lead adapters are available at most tool vendors.

The battery tester requires the CCA and RC rating of the battery, which should be on the battery label. See **Fig. 4**. Refer to the battery tester instruction manual for complete testing instructions.



06/24/2013 f151183

Fig. 3, The lead base of the post is the best place to clip.



06/24/2013 f151184

Fig. 4, 3.2 The label has the RC (reserve capacity) CCA (cold cranking amps) and SERIAL NO. (serial number).

3.3 If the battery fails, enter the battery serial number (see **Fig. 4**) and print out the result. The sensor windows on the tester and printer must be aligned to transmit the test results to the printer.

Freightliner Service Bulletin

FLA COE
 FLB COE
 FLD Conventional
 Business Class
 FLC 112 Conventional

> Century Class Conventional
 > Argosy COE
 Cargo
 > Columbia

> 122SD and Coronado
 > Business Class M2
 > Cascadia
 > 108SD/114SD

PATH CHECK - CABLE VOLTAGE DROP TEST			
Alternator Path Check		Rec Value	Accept Value
Carbon Pile:	DMM:		
4a. POS alternator, GND alternator. Load at alternator-rated amps.	POS alternator, POS batt pack	+	Total less than 0.7 V
4b. POS alternator, GND alternator. Load at alternator-rated amps.	NEG alternator, NEG batt pack	+	
Combine the voltage from the positive and negative cable drop tests.		=	

Checks 4a and 4b – Alternator Path Check

Setting up the Carbon Pile

Clip the Carbon Pile positive clamp on the alternator positive post nut, and the negative clamp on the alternator body.

NOTE: Ground may be on a post, not the body, for some Leece Neville alternators.

Reading Voltage Drop with the DMM

4a - Alternator positive cable and connections voltage drop test

4a.1 Clip one lead of the DMM to the threaded portion of the positive post on the alternator and the other lead to the positive lead base of one of the batteries. See **Fig. 5**.

4a.2 The battery pack should now be assembled, cables connected, and nuts tightened 10 to 15 lbf-ft (13 to 20 N-m). The load disconnect switch should be set to "On."

4a.3 Load the system with the carbon pile to the alternator amperage rating for 5 to 10 seconds. Record the voltage drop shown on the DMM. The DMM should show voltage greater than 0 V. If the DMM displays 0.00 V when the load is applied, there is a connection problem; check the DMM's connections and retest.

NOTE: The alternator amp rating can be found on the alternator, and in PartsPro. See **Fig. 6**.



06/24/2013

f151186

Fig. 5, Alternator Positive Cable Check



06/24/2013

f151187

Fig. 6, Rated amps can be found on the label.

FLA COE
FLB COE
FLD Conventional
Business Class
FLC 112 Conventional

> Century Class Conventional
> Argosy COE
> Cargo
> Columbia

> 122SD and Coronado
> Business Class M2
> Cascadia
> 108SD/114SD

**Freightliner
Service Bulletin**

4b - Alternator negative cable and connections voltage drop test

4b.1 Clip one lead of the DMM to the alternator body and the other to the negative lead base of one of the batteries.

NOTE: Ground may be on a post, not the body, for some Leece Neville alternators.

4b.2 Load the system with the carbon pile to the alternator amperage rating. Record the voltage drop shown on the DMM.

Combine the voltage drop of the positive and negative cable voltage drop tests; the total should not exceed 0.7 V. If total voltage drop is greater than 0.7 V, go to **Check 6**, then test voltage drop again. If total drop is less than 0.7 V, go to the next check.

Starter Path Check — EPA10, EPA04 Engines			
Carbon Pile:	DMM:	Rec Value	Accept Value
5a. POS alternator, GND alternator. Load at 500 amps.	POS starter, POS batt pack	+	Total less than 0.7 V
5b. POS alternator, GND alternator. Load at 500 amps.	NEG starter, NEG batt pack	+	
Combine the voltage from the positive and negative cable drop tests.		=	

NOTE: EPA07 vehicles with jump start posts connected to the starter can be tested using this EPA10, EPA04 vehicle procedure by placing the carbon pile clamps on the jump posts instead of the alternator in 5a and 5b. Using the jump posts will include them and their cables to the starter in the drop test.

NOTE: On EPA04 and EPA07 vehicles equipped with a load disconnect switch, expect up to a 0.5 V drop across the load disconnect switch.

Starter Path Check – Checks 5a and 5b – EPA10, EPA04

Setting up the Carbon Pile

Clip the carbon pile positive clamp on the alternator positive post and the negative clamp on the alternator body. See **Fig. 7**.

NOTE: Ground may be on a post, not the body, for some Leece Neville alternators.

Reading Voltage Drop with the DMM

5a - Starter positive cable and connections voltage drop test

5a.1 Clip the DMM to the threaded portion of the positive post on the starter and the positive lead base of one of the batteries. See **Fig. 8**.

IMPORTANT: If the positive alternator cable is smaller than 2/0 AWG, use the "Starter Path Check - EPA07" procedure instead.

5a.2 Load the system with the carbon pile at 500 amps. Record the voltage drop shown on the DMM.

5b - Starter negative cable and connections voltage drop test

5b.1 Clip the DMM to the threaded portion of the negative post on the starter and the negative lead base of one of the batteries.

5b.2 Load the system with the carbon pile to 500 amps. Record the voltage drop shown on the DMM.

Freightliner Service Bulletin

FLA COE
 FLB COE
 FLD Conventional
 Business Class
 FLC 112 Conventional

> Century Class Conventional
 > Argosy COE
 > Cargo
 > Columbia

> 122SD and Coronado
 > Business Class M2
 > Cascadia
 > 108SD/114SD



06/24/2013

f151188

Fig. 7, For EPA10 and EPA04 engines, the starter path can be checked by loading the circuit at the alternator.

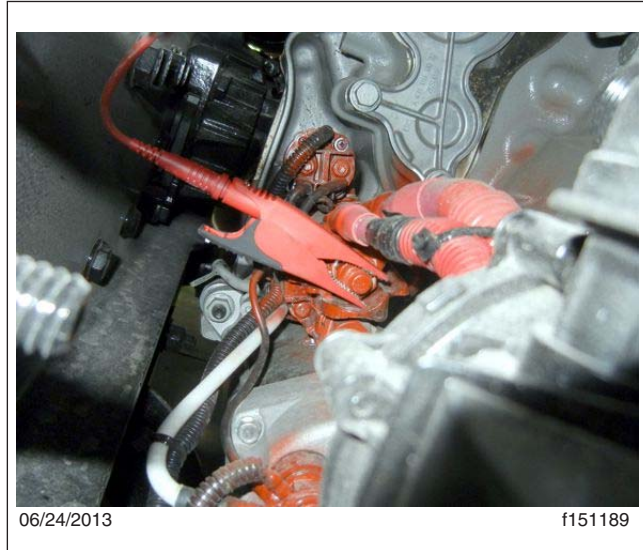

06/24/2013

f151189

Fig. 8, Location of the starter positive post.

Combine the voltage drop of the positive and negative cable voltage drop tests; the total should not exceed 0.7 V. If total voltage drop is greater than 0.7 V, go to **Check 6**, then test voltage drop again. If total drop is less than 0.7 V, go to **Check 6** but do not retest voltage drop.

Starter Path Check — EPA07 Engines		Rec Value	Accept Value
Amp Clamp and DMM Location:	Engine:		
5a. Amp clamp around POS starter cable for starter draw.	Crank engine, under 30 sec.		N/A
5b. DMM on POS battery pack cable and POS starter post.	Crank engine, under 30 sec.	+	Less than max V drop in Table 2 .
5c. DMM on NEG battery pack cable and NEG starter post.	Crank engine, under 30 sec.	+	
Combine the voltage from the positive and negative cable voltage drop tests.		=	

On crank, the starter cable is likely to have between 400 and 1000 amps of current running through it. This test uses an amp clamp to view the crank amperage. The allowed voltage drop depends on the crank amperage.

NOTE: This test may require an assistant.

Starter Path Check – Checks 5a, 5b, and 5c – EPA07 only

5a - Measuring crank amperage with amp clamp

5a.1 Place an amp clamp on the positive starter cable, set it to read current between 400 and 1000 amps, and zero it. Make sure the ammeter can read, and is set to read, this range before proceeding. See **Fig. 9**.

5b - Starter positive cable voltage drop test

5b.1 Clip the DMM to the threaded portion of the positive post on the starter and the positive lead base of one of the batteries.

5b.2 Crank the engine. After the voltage reading normalizes (about 2 to 3 seconds), but before the engine starts, record the voltage drop shown on the DMM.

FLA COE
 FLB COE
 FLD Conventional
 Business Class
 FLC 112 Conventional

> Century Class Conventional
 > Argosy COE
 > Cargo
 > Columbia

> 122SD and Coronado
 > Business Class M2
 > Cascadia
 > 108SD/114SD

**Freightliner
 Service Bulletin**



Fig. 9, Measure the crank amperage with an amp clamp on the positive starter cable during crank.

IMPORTANT: Do not crank for longer than 30 seconds. Allow the starter to cool for 2 minutes between crank events.

5c - Starter negative cable voltage drop test

5c.1 Clip the DMM to the threaded portion of the negative post on the starter and the negative lead base of one of the batteries.

5c.2 Crank the engine. After the voltage reading normalizes (about 2-3 seconds), but before the engine starts, record the voltage drop shown on the DMM.

Combine the voltage drop of the positive and negative cable voltage drop tests. Look up the crank amperage recorded using **Table 2**; total voltage drop from the two tests should not exceed the value given. If total voltage drop is greater than the allowed voltage, go to **Check 6**, then test voltage drop again. If total drop is within the allowed value, go to **Check 6** but do not retest voltage drop.

Max. Acceptable Combined V Drop by Amperage	
Amps	Max. Acceptable Combined V Drop
375-449	0.6
450-549	0.7
550-624	0.8
625-724	0.9
725-799	1.0
800-874	1.1
875-974	1.2

Freightliner Service Bulletin

FLA COE
 FLB COE
 FLD Conventional
 Business Class
 FLC 112 Conventional

> Century Class Conventional
 > Argosy COE
 > Cargo
 > Columbia

> 122SD and Coronado
 > Business Class M2
 > Cascadia
 > 108SD/114SD

Max. Acceptable Combined V Drop by Amperage	
Amps	Max. Acceptable Combined V Drop
975-1025	1.3

Table 2, Max. Acceptable Combined V Drop by Amperage

6. Check all cable connections for corrosion and torque. Repair or replace if needed, then test again.

Check 6 – Check all cable connections for corrosion and torque. See Fig. 10 and Fig. 11. Repair or replace if needed, then test again.

Loose connections can cause intermittent problems as well as higher resistance, and are likely to have corrosion. Most battery labels will specify the torque value; if the torque value cannot be found, use 10 to 15 lbf-ft (13 to 20 N-m).

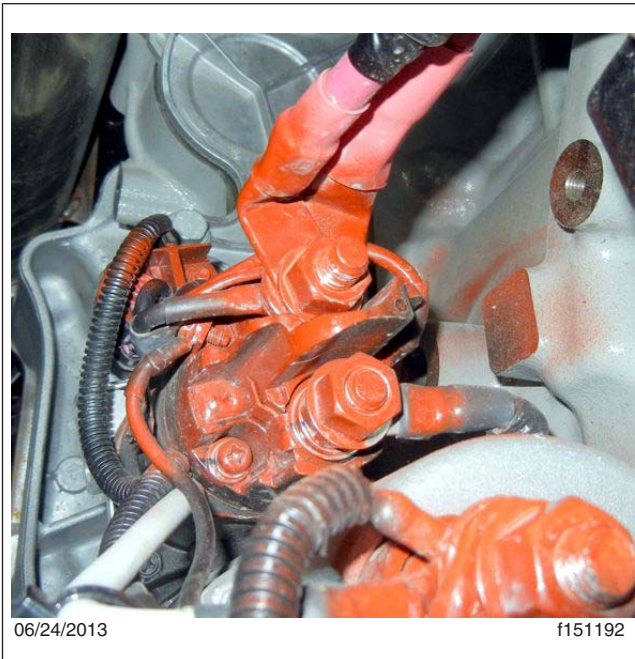

Fig. 10, Check the positive post on the starter solenoid for loose cables and corrosion.



Fig. 11, Check the battery connections for looseness and corrosion. Check the torque on the connections.

FLA COE
 FLB COE
 FLD Conventional
 Business Class
 FLC 112 Conventional

> Century Class Conventional
 > Argosy COE
 Cargo
 > Columbia

> 122SD and Coronado
 > Business Class M2
 > Cascadia
 > 108SD/114SD

ADDITIONAL BATTERY LOADS CHECK		
Key-off Loads	Rec Value	Accept Value
7. Key off, Load Disconnect Switch set to "Off" (if equipped). Wait 10 minutes for all loads to stop. Set amp clamp to a lower range setting. Zero amp clamp away from the vehicle. For each POS cable leaving batt pack, clamp the cable and record the amperage. If more than 1.0 amp, find sources of drain and remedy as needed.	+	Add amps. Total must be less than 1 amp.
	+	
	+	
	=	

Check 7 – Detail, Key-off Loads Check

A key-off load is an electrical load that still draws current from the batteries when the ignition remains off, and in some cases, when the load disconnect switch is off. Some devices, such as the engine controller, the antilock braking system (ABS), and the radio memory, are intended to draw a very low current continuously. In long-term parking situations, however, these drains may discharge the batteries enough to cause a no-start condition. Key-off loads tend to be measured in milliamps (mA).

7.1 Set the Load Disconnect Switch to "Off." Shut the door, and wait 10 minutes after shutting the door for all "keep-alives" (signals sent between devices) to turn off.

NOTE: On vehicles with a SAM module, the SAM will wake up for a self-check after 30 minutes of inactivity, then turn off.

7.2 Zero the amp clamp away from the vehicle to ensure that all battery draw—including "background" current—is detected upon measurement. The amp clamp should be set to a lower range, sensitive setting.

7.3 For each positive cable leaving the battery pack, clamp the cable and record the amperage. See **Fig. 12**. Add the amperages together. If the total is more than 1.0 amp, find the sources of drain and remedy as needed.



06/24/2013

f151195

Fig. 12, After zeroing the amp clamp away from the vehicle, measure the amperage in each positive cable leaving the battery pack.

Freightliner Service Bulletin

FLA COE
 FLB COE
 FLD Conventional
 Business Class
 FLC 112 Conventional

> Century Class Conventional
 > Argosy COE
 Cargo
 > Columbia

> 122SD and Coronado
 > Business Class M2
 > Cascadia
 > 108SD/114SD

Finding Sources of Battery Drain

Pull fuses individually on the circuit with the highest draw until the total combined amperage drops below 1.0 amp. From there, find the component on that particular circuit drawing the additional current. Repair or replace as needed.

NOTE: Opening and shutting doors will wake up system keepalives. If a door is opened during the procedure, wait 10 minutes after closing the door before measuring draw.

NOTE: The LVD (low voltage disconnect) could be bypassed by inverters or other aftermarket installed systems.

Key-on Loads	Rec Value	Accept Value
8. Amp clamp on POS alt cable. ENG at IDLE, turn on driver's normal use loads. If load is more than 80% rated amps, find sources of draw and/or upgrade alternator. Retest after remedying.		Total less than 80% rated amps.

Check 8 – Key-On Loads Check

This test looks at the "normal use" loads of the vehicle during normal operation conditions by measuring draw at the alternator positive cable. "Normal use" should include high beams, radio, blower, and additional driver accessories.

At idle, the total load should not be above 80% of the alternator's rated output (e.g. 270 amps x .80 = 216 amps). See **Table 2** for 80% load by alternator amperage rating. If the normal use load is higher, then a number of related issues can be at play that are outside the scope of this troubleshooting topic. These might include high-draw loads, and circuit voltage drop (from corrosion, looseness, or damage).

Max. Acceptable Key-on Load by Alternator Amperage Rating	
Amp	Max. Load
135	108
160	128
185	148
200	160
240	192
270	216
275	220

Table 3, Max. Acceptable Key-on Load by Alternator Amperage Rating

If all systems are functioning properly, but the normal use load exceeds the alternator rating, either a higher rated alternator should be installed, or non-essential high-draw loads should be permanently removed from the system.

FLA COE
 FLB COE
 FLD Conventional
 Business Class
 FLC 112 Conventional

> Century Class Conventional
 > Argosy COE
 Cargo
 > Columbia

> 122SD and Coronado
 > Business Class M2
 > Cascadia
 > 108SD/114SD

**Freightliner
 Service Bulletin**

CHARGING SYSTEM CHECK - ALTERNATOR		Engine Throttle	Key Position	Carbon Pile	Rec Value	Accept Value
9a. DMM on POS and NEG of batt pack. (Undercharge check)		IDLE	KEY ON	NO LOAD		13.2-14.8 V
9b. DMM on POS and NEG of batt pack. (Overcharge check)		PARTIAL	KEY ON	NO LOAD		13.2-14.8 V
9c. DMM on POS and NEG of batt pack. (Overcharge check)		WIDE OPEN	KEY ON	NO LOAD		13.2-14.8 V
Carbon Pile:		DMM:				
10a.POS and NEG of batt pack.	POS and NEG of batt pack.	PARTIAL	KEY ON	70% of alt rated		Within .2 V of Check 9
10b.POS and NEG of batt pack.	POS and NEG of batt pack.	WIDE OPEN	KEY ON	70% of alt rated		Within .2 V of Check 9

Checks 9a and 9b – Under and Overcharge Checks

9a. With a DMM, probe any battery in the primary battery pack at the negative and positive lead bases of the battery posts. With the engine running at idle and no loads turned on, record the voltage at the pack.

9b. With the engine running at partial throttle and no loads turned on, record the voltage at the pack.

9c. With the engine running at wide open throttle and no loads turned on, record the voltage at the pack.

In both cases, the voltage should be above 13.2 V, and higher than it was before starting the engine. If not, the alternator is undercharging, and should be replaced.

If the voltage reads above 14.8 V, the alternator is overcharging the batteries. Check the remote sense circuit before condemning the alternator.

Check 10 – 70% of Rated Output Check

10a.1 With a DMM, probe any battery in the primary battery pack at the negative and positive battery posts.

10a.2 Clamp the carbon pile to the positive and negative battery pack leads.

10a.3 Place an amp clamp around the positive alternator cable. The amp clamp will be used to measure the total draw on the alternator from the carbon pile and other system loads. See **Fig. 13**.

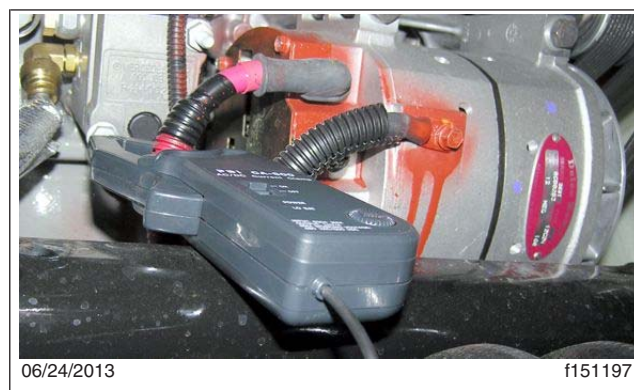

Fig. 13, Use an amp clamp around the positive alternator cable to measure the draw of the carbon pile.

Freightliner Service Bulletin

FLA COE
 FLB COE
 FLD Conventional
 Business Class
 FLC 112 Conventional

> Century Class Conventional
 > Argosy COE
 > Cargo
 > Columbia

> 122SD and Coronado
 > Business Class M2
 > Cascadia
 > 108SD/114SD

10a.4 With the engine running at partial throttle, adjust the carbon pile until the amp clamp reads 70% of the alternator rated amperage (e.g. 270 amps x .70 = 189 amps). See **Table 4**. With this load applied, record the voltage at the battery pack.

10b. With the engine running at wide open throttle, adjust the carbon pile until the amp clamp reads 70% of the alternator rated amperage (e.g. 270 amps x .70 = 189 amps). See **Table 4**. With this load applied, record the voltage at the battery pack.

While the load is applied, the voltage reading on the DMM should not drop more than 0.2 V below the reading in step 9b (the partial throttle, no load condition). If the voltage difference is more than 0.2 V, replace the alternator, then perform tests 9a, 9b, and 9c again to verify the repair.

IMPORTANT: The voltage will drop if the carbon pile is drawing more than 70% of the alternator rating. Do not replace if a low voltage reading was seen with a load above 70%. Instead, test again with 70% of the alternator's rated load.

Target Carbon Pile Amp Draw by Alternator Rating	
Alternator Rating (Amp)	Use Carbon Pile Draw of (Amp)
135	95
160	112
185	130
200	140
240	168
270	189
275	193

Table 4, Target Carbon Pile Amp Draw by Alternator Rating

Remote Sense Check	Engine	Key Position	Carbon Pile	Rec Value	Accept Value
11a.DMM on Rem Sense post, NEG on alt GND.	ENG OFF	KEY OFF	NO LOAD		Less than .05 V diff
11b.DMM on POS of alternator, NEG on alt GND.	ENG OFF	KEY OFF	NO LOAD		

Remote Sense

The remote sense circuit allows the alternator to directly measure battery voltage, in addition to the measurement it takes from the large cables. With these two voltage measurements, the alternator calculates the amount of voltage drop over the large cables and adjusts its output to provide the at-battery regulated voltage.

Freightliner vehicles come equipped with either Delco Remy or Leece-Neville alternators, most of which have remote sense.

Checks 11a and 11b – Remote Sense Check

11a. With the key off, place the DMM probes at alternator ground and remote sense post/terminal. See **Fig. 14**. Record the voltage.

11b. Place the DMM probes at the alternator body and the positive post of the alternator. Depending on the alternator, the positive post may be labelled "POS" "B+" or "+". Record the voltage.

Powernet Troubleshooting Guide: Batteries, Path, Alternator, and Starter

54-278

Freightliner Service Bulletin

FLA COE
FLB COE
FLD Conventional
Business Class
FLC 112 Conventional

> Century Class Conventional
> Argosy COE
> Cargo
> Columbia

> 122SD and Coronado
> Business Class M2
> Cascadia
> 108SD/114SD

NOTE: Ground may be on a post, not the body, for some Leece Neville alternators.

The values should be within .05 V. If voltage is out of specification, then the remote sense circuit may be shorted or open. First, check the remote sense fuse. The remote sense fuse is located in the Powernet Distribution Box (PNDB) on EPA10 vehicles (see **Fig. 15**), and in the Powertrain PowerNet Distribution Module (PTPDM) on EPA07 vehicles (see **Fig. 16**). Refer to the applicable workshop or service manual or EZ wiring for the remote sense fuse location on EPA07 or older vehicles. If the fuse is fine, look for opens or shorts in the remote sense circuit.

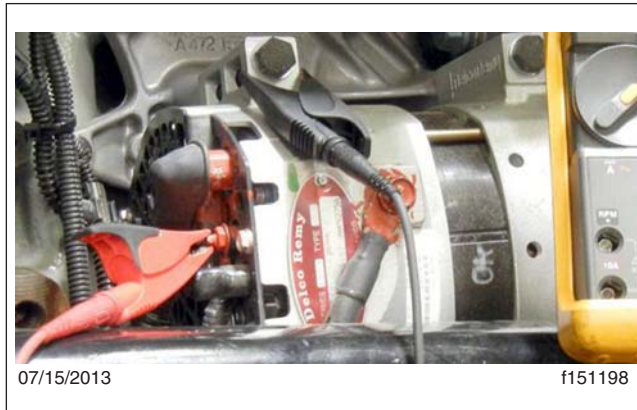

Fig. 14, Clip the DMM positive to the remote sense post and the DMM negative to the alternator body.



Fig. 15, EPA10 vehicles: 5 amp remote sense fuse, location D in the Powernet Distribution Box (PNDB).

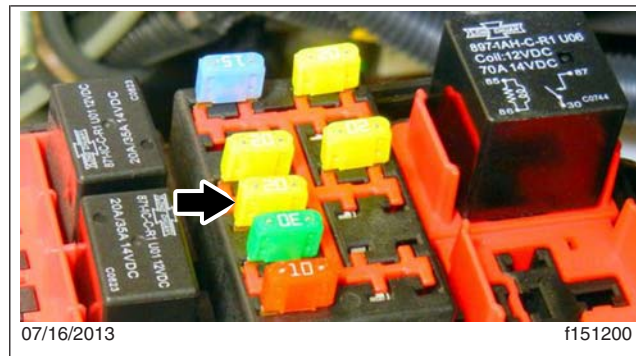

Fig. 16, EPA07 vehicles: 20 amp remote sense fuse, location F7 in the Powernet Distribution Module (PTPDM).

If the remote sense fuse and circuit are fine, but the alternator is still overcharging, replace the alternator.

Freightliner Service Bulletin

FLA COE
FLB COE
FLD Conventional
Business Class
FLC 112 Conventional

> Century Class Conventional
> Argosy COE
> Cargo
> Columbia

> 122SD and Coronado
> Business Class M2
> Cascadia
> 108SD/114SD

12 Check alternator mounting, pulley, and belt for proper condition and operation.

Check 12 – Alternator Pulley, Belt, and Mounting

Check the alternator drive belt for glazing, cracking, and wear. See **Fig. 18**. Check the belt tensioner for proper operation. Check that the alternator is securely fastened to the engine and that the pulley is in proper alignment with the drive belt system. Check for pulley damage. See **Fig. 17**. Repair or replace as necessary.

See the vehicle workshop manual **Group 01 – Engine** for more information on drive belt and pulley inspection.

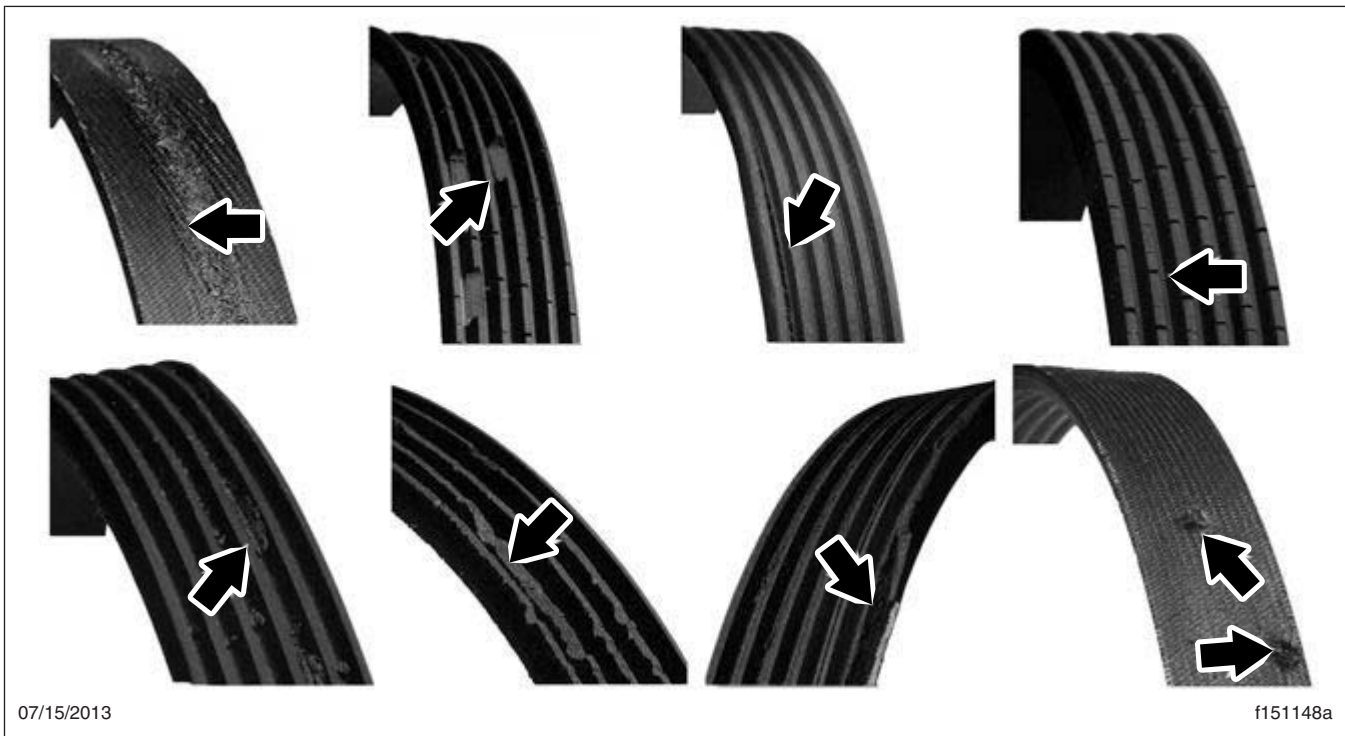

Fig. 17, Types of Belt Damage Requiring Belt Replacement

FLA COE
FLB COE
FLD Conventional
Business Class
FLC 112 Conventional

> Century Class Conventional
> Argosy COE
> Cargo
> Columbia

> 122SD and Coronado
> Business Class M2
> Cascadia
> 108SD/114SD

Freightliner
Service Bulletin

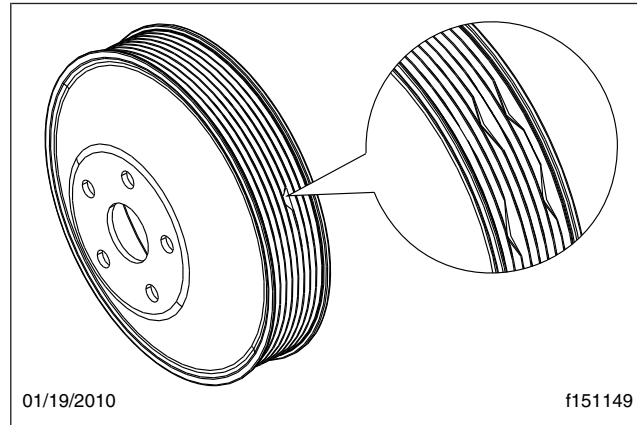

Fig. 18, Pulley Damage Requiring Pulley Replacement

Troubleshooting the Starting System

Before using the Starting System Troubleshooting, complete the Powernet Troubleshooting Worksheet. Batteries, cables, and the alternator must be checked for correct function before troubleshooting the starter. This troubleshooting should not be performed until the Powernet Troubleshooting Worksheet has been completed.

Crank the engine with no loads (headlights, blower, etc.). Identify the symptom.

Symptom: Grinding Noise

Remove the starter and check the pinion and ring gear for damage. See **Fig. 19**.

- If damage is found, replace damaged parts as needed.
- If no damage is found, replace the starter.

Symptom: No Crank or Intermittent Crank

NOTE: Uncleared abutments should not happen more frequently than approximately 1 out of 100 starts.

Test the mag switch using a DMM (positive probe on the IMS input signal, negative probe on a known good ground) while cranking:

- If less than 9 V, FAIL:
 - For Cascadia, use DiagnosticLink to check the Starter Relay Output signal. If the signal is present, check SAM Cab connector X19 pin 3 for continuity.
 - For Business Class M2, use ServiceLink to check the Starter Relay Output signal. If the signal is present, check bulkhead module connector B4 pin B for continuity.
 - For all other models, troubleshoot the circuit and check all of the applicable starter interlocks and control systems. Find more information using PartsPro and EZwiring.

Freightliner Service Bulletin

FLA COE
FLB COE
FLD Conventional
Business Class
FLC 112 Conventional

> Century Class Conventional
> Argosy COE
Cargo
> Columbia

> 122SD and Coronado
> Business Class M2
> Cascadia
> 108SD/114SD

- If greater than or equal to 9 V, PASS; with the key off, rotate the engine 90 degrees using a barring tool. Remove the tool, and try to crank the engine again:
 - If the engine was hard to turn over and still does not crank, consult the engine manufacturer.
 - If the engine cranks, shut down the engine, remove the starter, and inspect the starter pinion and ring gear. See Inspecting the Ring Gear. Replace damaged parts if found. If no damage is found, replace the starter.

Symptom: Slow Turnover

If the ambient temperature is less than 32°F (0°C), slow turnover is normal.

If the ambient temperature is greater than 32°F (0°C), check the engine for faults and check the condition of the engine oil. If fault codes are found, or the engine oil indicates an issue, consult the engine manufacturer. If there are no fault codes, and the engine oil passes inspection, replace the starter.

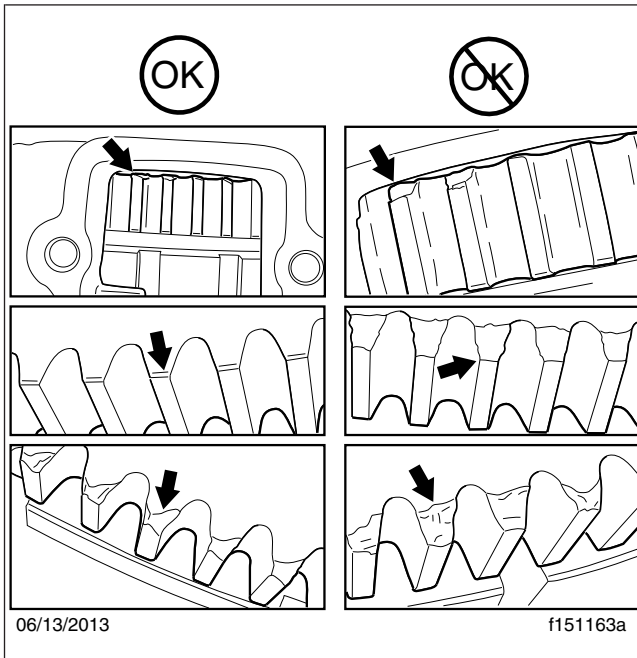

Fig. 19, Acceptable and Unacceptable Ring Gear Wear

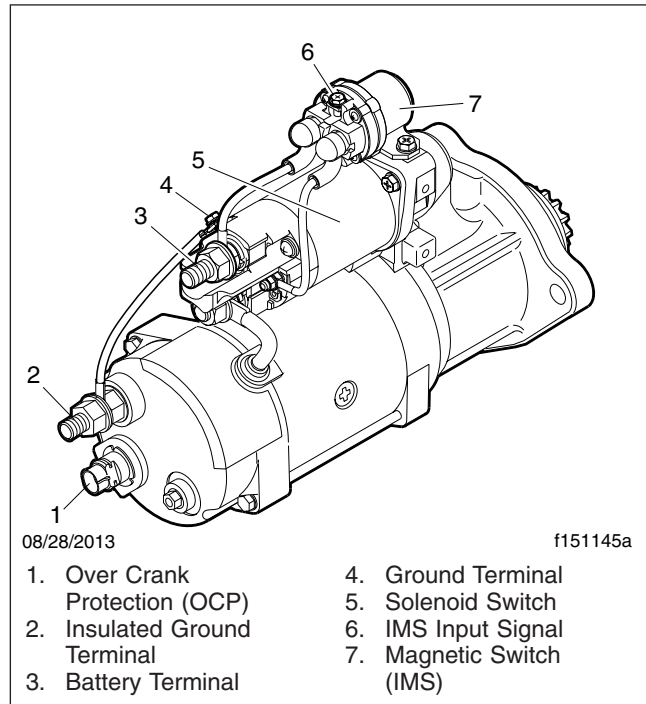

Fig. 20, Starter Components and Terminals

Warranty

This is an informational bulletin only. Warranty does not apply.

FLA COE
FLB COE
FLD Conventional
Business Class
FLC 112 Conventional

> Century Class Conventional
> Argosy COE
Cargo
> Columbia

> 122SD and Coronado
> Business Class M2
> Cascadia
> 108SD/114SD

**Freightliner
Service Bulletin**

PowerNet Assessment Worksheet - Do Entire Worksheet in Order (Checks 1 to 12)

IMPORTANT: Record the initial value of each check on the worksheet before performing repairs.

BATTERIES CHECK	DMM (Digital Multimeter):	Rec Value	Accept Value
1. Check battery pack voltage to determine state of charge. Charge pack to 100%. If unable, go to 3, "Break pack."	POS and NEG batt pack.		12.8V AGM 12.6V Flood
2. Remove surface charge: HVAC blower, lights on, 5 min.			
3. Break pack into individual batteries and test each with an approved battery tester. (Remove NEG cables first!) Replace batteries if instructed by the tester. All batteries must pass the battery tester evaluation before troubleshooting continues.		Batt 1: PASS or FAIL	
		Batt 2: PASS or FAIL	
		Batt 3: PASS or FAIL	
		Batt 4: PASS or FAIL	

PATH CHECK - CABLE VOLTAGE DROP TEST			
Alternator Path Check		Rec Value	Accept Value
Carbon Pile:	DMM:		
4a. POS alternator, GND alternator. Load at alternator-rated amps.	POS alternator, POS batt pack	+	Total less than 0.7 V
4b. POS alternator, GND alternator. Load at alternator-rated amps.	NEG alternator, NEG batt pack	+	
Combine the voltage from the positive and negative cable drop tests.		=	

IMPORTANT: EPA10/EPA04 and EPA07 vehicles require different starter path checks because of differences in cable routing.

IMPORTANT: If the positive alternator cable is smaller than 2/0 AWG, use "Starter Path Check - EPA07."

NOTE: EPA07 vehicles with jump start posts connected to the starter can be tested using the EPA10/EPA04 check by placing the carbon pile clamps on the jump start posts instead of the alternator in 5a and 5b.

Starter Path Check — EPA10, EPA04 Engines		Rec Value	Accept Value
Carbon Pile:	DMM:		
5a. POS alternator, GND alternator. Load at 500 amps.	POS starter, POS batt pack	+	Total less than 0.7 V
5b. POS alternator, GND alternator. Load at 500 amps.	NEG starter, NEG batt pack	+	
Combine the voltage from the positive and negative cable voltage drop tests.		=	
6. Check all cable connections for corrosion and torque. Repair or replace if needed, then test again.			

Starter Path Check — EPA07 Engines		Rec Value	Accept Value
Amp Clamp and DMM Location:	Engine:		
5a. Amp clamp around POS starter cable for starter draw.	Crank engine, under 30 sec.		N/A
5b. DMM on POS battery pack cable and POS starter post.	Crank engine, under 30 sec.	+	Less than max V drop in Table 5.
5c. DMM on NEG battery pack cable and NEG starter post.	Crank engine, under 30 sec.	+	
Combine the voltage from the positive and negative cable voltage drop tests.		=	
6. Check all cable connections for corrosion and torque. Repair or replace if needed, then test again.			

Freightliner Service Bulletin

FLA COE
 FLB COE
 FLD Conventional
 Business Class
 FLC 112 Conventional

> Century Class Conventional
 > Argosy COE
 Cargo
 > Columbia

> 122SD and Coronado
 > Business Class M2
 > Cascadia
 > 108SD/114SD

Amps	Max. Acceptable Combined V Drop
375-449	0.6
450-549	0.7
550-624	0.8
625-724	0.9
725-799	1.0
800-874	1.1
875-974	1.2
975-1025	1.3

Table 5, for Check 5, Max. Acceptable Combined V Drop by Amperage

ADDITIONAL BATTERY LOADS CHECK		
Key-off Loads	Rec Value	Accept Value
7. Key off, Load Disconnect Switch set to "Off" (if equipped). Wait 10 minutes for all loads to stop. Set amp clamp to a lower range setting. Zero amp clamp away from the vehicle. For each POS cable leaving batt pack, clamp the cable and record the amperage. If more than 1.0 amp, find sources of drain and remedy as needed.	+	Add amps. Total must be less than 1 amp.
	+	
	+	
	=	
Key-on Loads		
8. Amp clamp on POS alt cable. ENG at IDLE, turn on driver's normal use loads. If load is more than 80% rated amps, find sources of draw and/or upgrade alternator. Retest after remedying.		Total less than 80% rated amps.

CHARGING SYSTEM CHECK - ALTERNATOR		Engine Throttle	Key Position	Carbon Pile	Rec Value	Accept Value
9a. DMM on POS and NEG of batt pack. (Undercharge check)		IDLE	KEY ON	NO LOAD		13.2-14.8 V
9b. DMM on POS and NEG of batt pack. (Overcharge check)		PARTIAL	KEY ON	NO LOAD		13.2-14.8 V
9c. DMM on POS and NEG of batt pack. (Overcharge check)		WIDE OPEN	KEY ON	NO LOAD		13.2-14.8 V
Carbon Pile:	DMM:					
10a. POS and NEG of batt pack.	POS and NEG of batt pack.	PARTIAL	KEY ON	70% of alt rated		Within .2 V of Check 9
10b. POS and NEG of batt pack.	POS and NEG of batt pack.	WIDE OPEN	KEY ON	70% of alt rated		Within .2 V of Check 9
If value is outside acceptable range, replace alternator and retest system.						
Remote Sense Check						
11a. DMM on Rem Sense post, NEG on alt GND.		ENG OFF	KEY OFF	NO LOAD		Less than .05 V diff
11b. DMM on POS of alternator, NEG on alt GND.		ENG OFF	KEY OFF	NO LOAD		
If remote sense voltage is outside range, but the remote sense fuse and circuit are ok, replace alternator.						
12. Check alternator mounting, pulley, and belt for proper condition and operation.						