



TECHNICAL SERVICE BULLETIN

Title: Meritor Axle S-cam Brake Assembly Fasteners

Date: December 13, 2016

Vehicles: KME Predator Aerials and Predator SS Aerials

VIN Numbers:	GSO	VIN NUMBER
	5761	1K9AF64865N058881
	7072	1K9AF64839N058598
	7323	1K9AF64839N058715
	7362	1K9AF64849N058738
	7462	1K9AF6484AN058811
	7658	1K9AF648XAN058828
	7659	1K9AF6481AN058829
	8059	1K9AF6480BN058113
	9670	1K9AF6483FN058998
	9961	1K9AF6M81GN058323

Problem: Meritor axle S-cam brake bracket mounting bolts may have become loose, missing or broken causing the S-cam bracket to rotate causing the brakes to engage without request.

Corrective Action: Inspect all of the Meritor S-cam brake assembly fasteners and components as directed in the Meritor technical service bulletin. If S-cam brake assembly fasteners are identified as loose, Missing, and/or broken, please contact Chris Morrison, KME Warranty Manager.

Work Instructions: See Attached Meritor TSB and page 56 from Meritor Maintenance Manual 4 for S-cam bracket and brake chamber mounting fastener torque specifications.

Parts List: To Be Determined.

KME CONTACT: Chris Morrison, Warranty Manager

TELEPHONE: 570-669-5577

EMAIL: cmorrison@kmefire.com

MAILING ADDRESS: KME Fire Apparatus
Plant #8
One Industrial Complex
Nesquehoning, PA 18240

ATTENTION: Mr. Chris Morrison

TP-1714
Issued 12-16



Inspecting Meritor S-Cam Brake Assembly Fasteners

Hazard Alert Messages

Read and observe all Warning and Caution hazard alert messages in this publication. They provide information that can help prevent serious personal injury, damage to components, or both.

⚠ WARNING

To prevent serious eye injury, always wear safe eye protection when you perform vehicle maintenance or service.

Park the vehicle on a level surface. Block the wheels to prevent the vehicle from moving. Support the vehicle with safety stands. Do not work under a vehicle supported only by jacks. Jacks can slip or fall over. Serious personal injury and damage to components can result.

⚠ ASBESTOS AND NON-ASBESTOS FIBERS WARNING

Some brake linings contain asbestos fibers, a cancer and lung disease hazard. Some brake linings contain non- asbestos fibers, whose long-term effects to health are unknown. You must use caution when you handle both asbestos and non-asbestos materials.

How to Obtain Additional Maintenance, Service and Product Information

Refer to Maintenance Manual 4, Cam Brakes and Automatic Slack Adjusters. To obtain this publication or Meritor axle maintenance manuals, visit Literature on Demand at meritor.com. Additional information can also be obtained by contacting the Meritor OnTrac™ Customer Call Center at 866-668-7221 (United States and Canada) or email: OnTrac@meritor.com.

Inspecting for Loose Brake Fasteners

This technical bulletin provides instructions for inspecting the fasteners on Meritor S-cam brakes for signs they may have loosened and lost clamp. Meritor recommends performing this inspection during the next regularly-scheduled maintenance visit. Refer to the table for recommended inspection and maintenance intervals.

Inspection Procedure

1. Wear safe eye protection. Park the vehicle on a level surface. Block the wheels to prevent the vehicle from moving.
2. Inspect for the following conditions which may indicate a loss of clamp or loosened fastener. Refer to Figure 1, Figure 2, Figure 3 and Figure 4 for fastener locations.

NOTE: Illustrations are for reference only. Other brake assemblies may differ in number or location of fasteners.

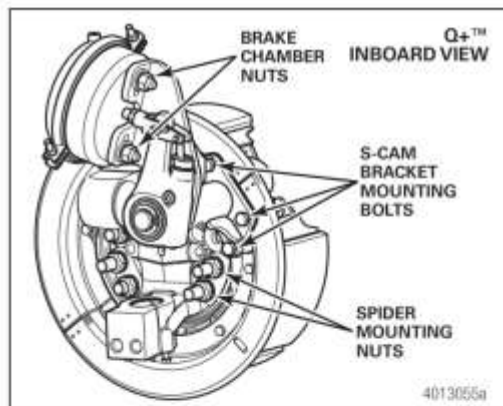

Figure 1

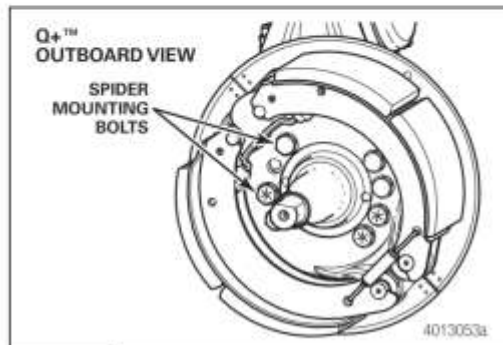

Figure 2

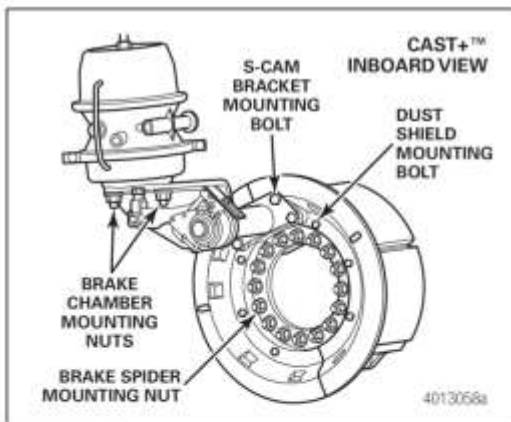

Figure 3

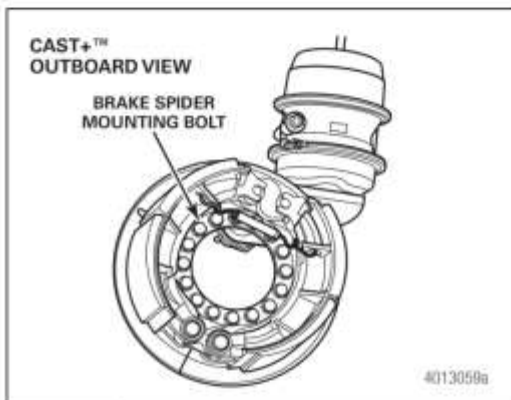

Figure 4

- A. Cracked chassis paint at the S-cam bracket mounting bolt head and mounting area.
- B. Signs of corrosion on or around any brake component mounting bolt surface, on the heads of bolts, and for trails of rust running below a bolt.
- C. Fretting on any of the mounting bolts.
- D. Flaking paint/primer on the mounting bolts or nuts.
- E. Missing or broken bolts.
- F. Misaligned stripes on bolts painted with a torque stripe.

CAUTION

Replace any fastener that has damaged threads. Do not reinstall and tighten a fastener with damaged threads. A fastener with damaged threads may not be able to achieve the correct clamp load. Damage to components may result.

3. If any fastener is found to be loose or suspected to be loose, inspect the fastener threads and brake hardware for damage.
 - **If the fastener or brake hardware is found to be damaged:** Replace as required.
 - **If the fastener and hardware can be reused:** Install and tighten to correct specification. Refer to Maintenance Manual 4 for S-cam bracket and brake chamber mounting fastener torque specifications. For brake assembly-to-axle mounting fastener torque specifications, refer to the appropriate Meritor axle maintenance manual.

Inspection and Maintenance Intervals

Application	Interval
Linehaul and General Service Vehicles	Q+™, Cast+™ and Q Series brakes every 100,000 miles (160 000 km), every six months, or the vehicle OEM recommendation, whichever comes first. P Series brakes every 50,000 miles (80 000 km), every six months, or the vehicle OEM recommendation, whichever comes first.
Heavy Service Vehicles	At least every 25,000 miles (40 234 km), four months, when you replace the seals and reline the brakes, or the vehicle OEM recommendation, whichever comes first.
Restricted Service Vehicles	Every six months, at each reline, every 10,000 miles (16 000 km), or the vehicle OEM recommendation, whichever comes first.



Meritor Heavy Vehicle Systems, LLC
2135 West Maple Road
Troy, MI 48064 USA
866-OnTrac1 (668-7221)
meritor.com

Information contained in this publication was in effect at the time the publication was approved for printing and is subject to change without notice or liability. Meritor Heavy Vehicle Systems, LLC, reserves the right to revise the information presented or to discontinue the production of parts described at any time.

Copyright 2016
Meritor, Inc.
All Rights Reserved

Printed in USA

TP-1714
Issued 12-16
(16579)

Torque Specifications

Cam Brakes

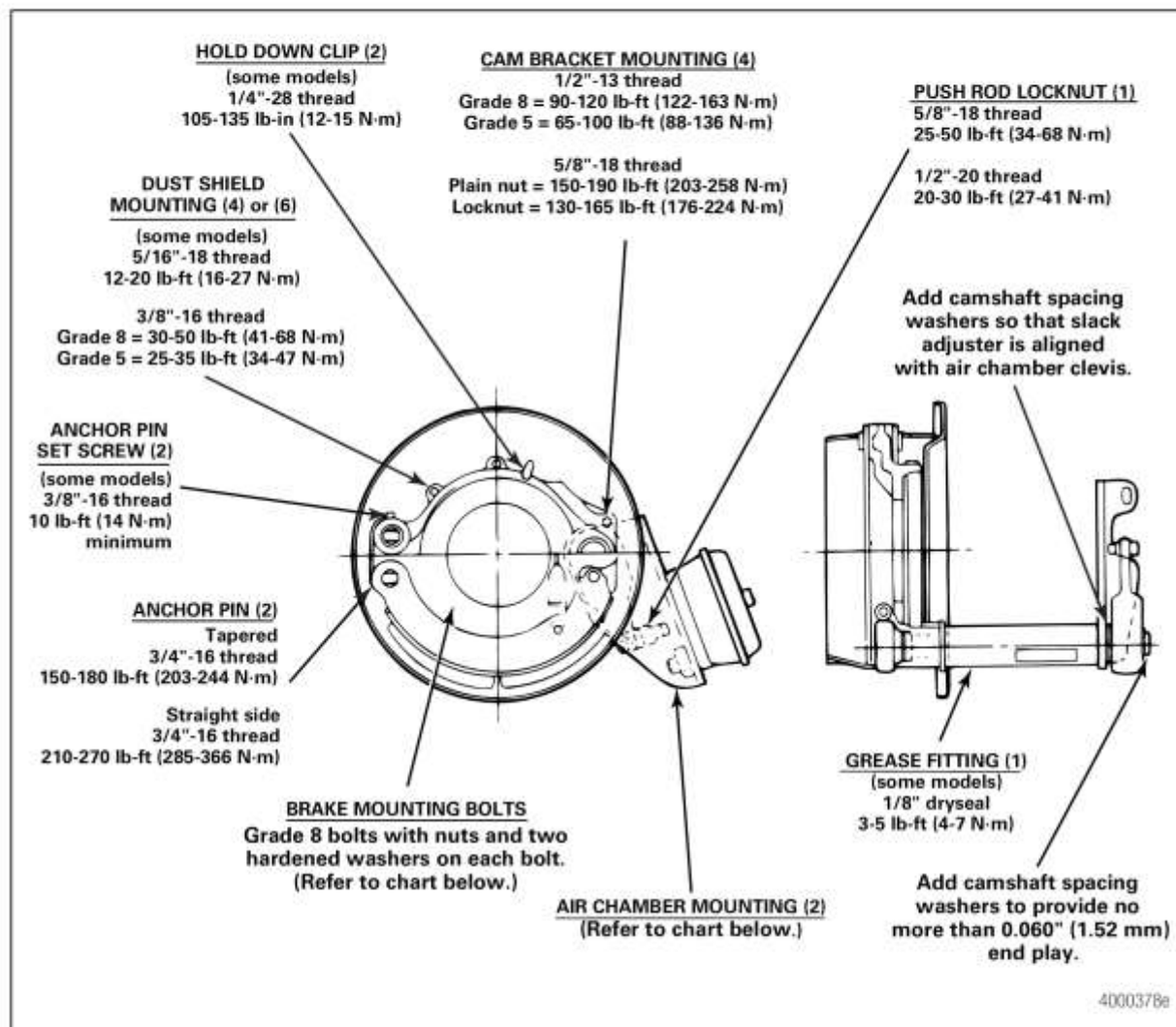

Figure 9.1

Table L: Brake Mounting Bolts

Bolt Size, Grade 8	Torque, lb-ft (N·m)
7/16"-20	60-75 (81-102)
1/2"-20	85-115 (115-156)
9/16"-18	130-165 (176-224)
5/8"-18	180-230 (244-312)