

© 2016 Mazda Motor of America, Inc.

Subject: AIR TEMPERATURE WILL NOT CHANGE	Bulletin No: 07-003/16
	Last Issued: 09/13/2016

BULLETIN NOTE

This bulletin supersedes the previously issued bulletin(s) listed below. The changes are noted below in Red beside the change bars.

Previously Issued TSBs:	Date(s) Issued
07-003/15	11/17/15 and 02/04/15

APPLICABLE MODEL(S)/VINS

2014-15 Mazda3 (Japan built with manual A/C) with VINS lower than JM1BM*****247593 (produced before December 1, 2014)

2014-16 Mazda3 (Mexico built with manual A/C) with VINS lower than 3MZBM*****317865 (produced before July 6, 2016)

DESCRIPTION

Some customers may complain that the air temperature from the air conditioner will not change with the air temperature control knob, and may be accompanied by some rattle noise from behind the dash board. This concern may be caused by the temperature control link being pulled out of the HVAC housing. To correct the problem, the temperature control link has been modified.

Customers having this concern should have their vehicle repaired using the following repair procedure.

CONSUMER NOTICE: The information and instructions in this bulletin are intended for use by skilled technicians. Mazda technicians utilize the proper tools/equipment and take training to correctly and safely maintain Mazda vehicles. These instructions should not be performed by "do-it-yourselfers." Customers should not assume this bulletin applies to their vehicle or that their vehicle will develop the described concern. To determine if the information applies, customers should contact their nearest authorized Mazda dealership. Mazda North American Operations reserves the right to alter the specifications and contents of this bulletin without obligation or advance notice. All rights reserved. No part of this bulletin may be reproduced in any form or by any means, electronic or mechanical---including photocopying and recording and the use of any kind of information storage and retrieval system ---without permission in writing.

REPAIR PROCEDURE

1. Verify customer concern.
2. Refer to the instructions on MS3 online or the Workshop Manual (section 07-40 CLIMATE CONTROL UNIT REMOVAL/INSTALLATION [MANUAL AIR CONDITIONER]) and check that the MIX LINK (Air mix link/Temperature control link) (A) is properly connected to the MIX DOOR CRANK (B) and works while rotating the temperature control knob.

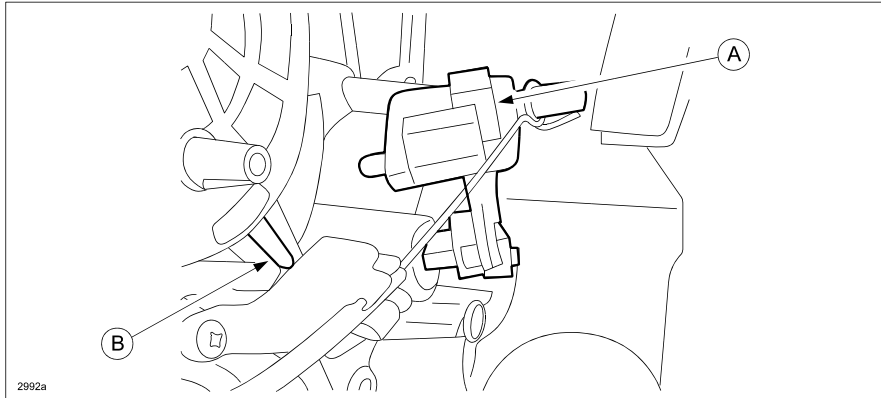

- a. If it works, this Service Bulletin does not apply. Refer to the instructions on MS3 online or Workshop Manual for troubleshooting and repair.
- b. If the MIX LINK is detached, proceed to the next step.

3. **Japan built vehicles:**

Replace the MIX LINK with a modified one. Refer to MS3 online (A/C UNIT DISASSEMBLY/ASSEMBLY). Make sure that the MIX LINK is fitted in the groove of the MIX DOOR CRANK and will not come out with movement.

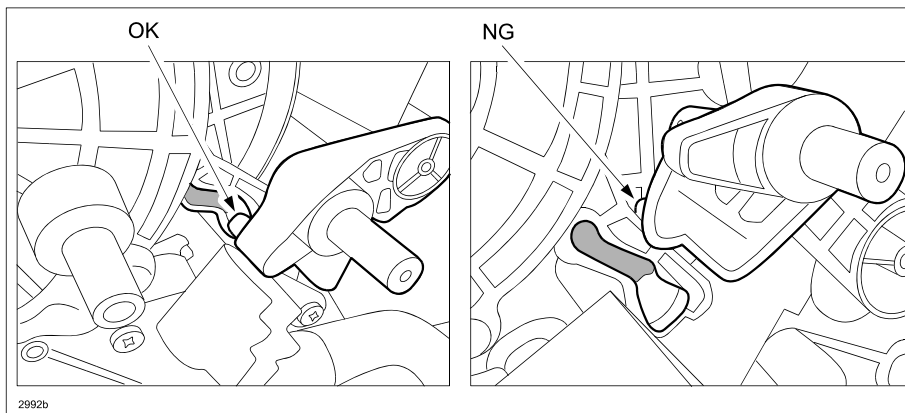

Mexico built vehicles:

Replace the A/C unit. Refer to MS3 online (A/C UNIT REMOVAL/INSTALLATION).

4. Install the parts in the reverse order.
5. Verify repair.

PART(S) INFORMATION

Japan built vehicles:

Part Number	Description	Qty.	Notes
BHS2-61-A20A	Link Set, Temp1	1	Japan built vehicles (JM1)

Mexico built vehicles:

Part Number	Description	Qty.	Notes
BJS7-61-130F	Heater Unit	1	
D651-68-162A	Clip, Trim	1	[R] for A-pillar trim (black) [before June 20, 2016]
D09W-68-162	Clip, Trim	1	[R] for A-pillar trim (natural) [after June 20, 2016]
9YA0-11-003A	Bolt	1	[R] for steering wheel
BBM4-61-J17	O-ring, Cooling Unit	1	[R] for cooler hose (LO), ID=13.40 mm
GJ6A-61-J19	O-Ring, No. 1	1	for cooler pipe, ID=6.70 mm
BP4K-61-242	Clamp, Hose	2	for heater hose
9YA0-20-682	Bolt	2	for dashboard

Clip (A) and Clip (B) of A-pillar trim (C)

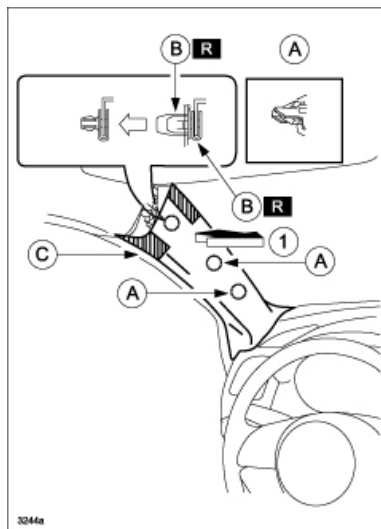

Grommet (B) for Lead Wire (A) by A-pillar trim (C)

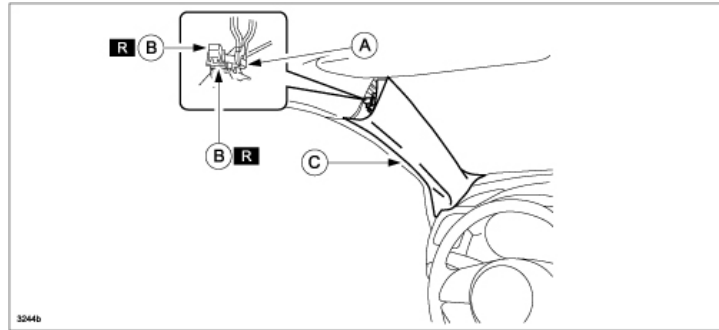

Lockbolt for Steering Wheel (A)

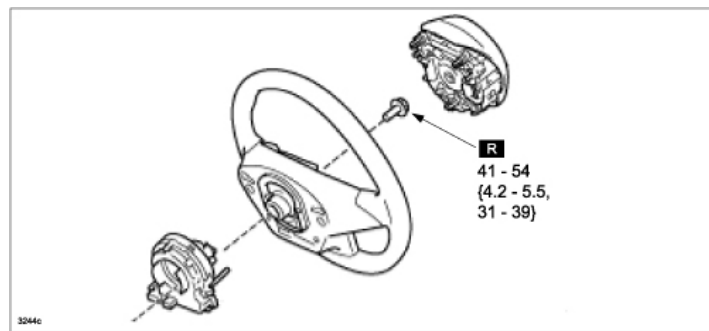

O-rings for Cooler Hose (LO) (A) and for Cooler Pipe (B)

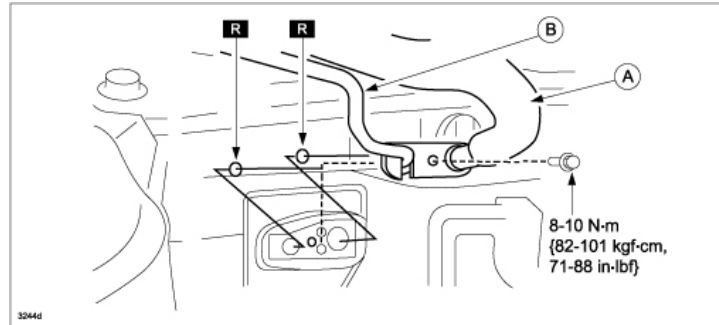

Clips for Heater Hose (A)

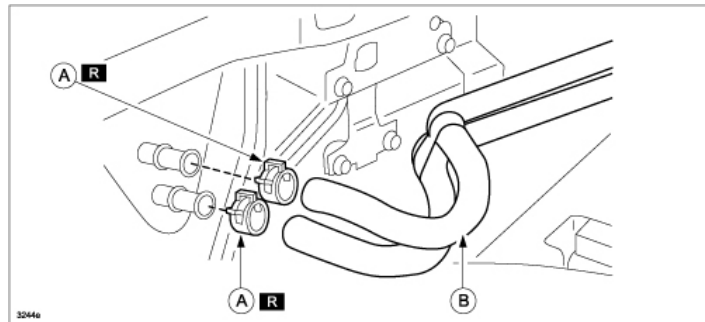

Bolt for Dashboard (A)

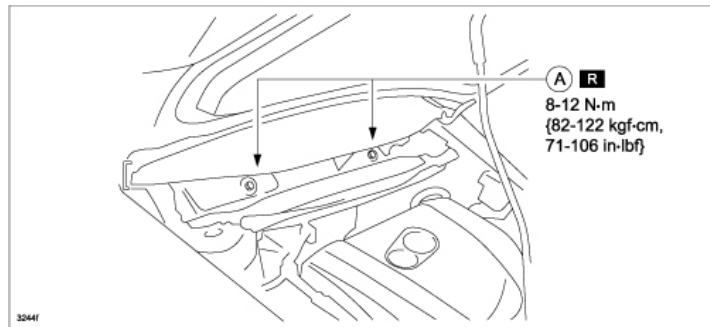

WARRANTY INFORMATION

NOTE:

- This warranty information applies only to verified customer complaints on vehicles eligible for warranty repair.
- This repair will be covered under Mazda's New Vehicle Limited Warranty.
- Additional diagnostic time cannot be claimed for this repair.

Japan built vehicles:

Warranty Type	A
Symptom Code	60
Damage Code	9E
Part Number Main Cause / Qty.	BHS2-61-A20A / 1
Operation Number / Labor Hours:	XXKBOXARX / 0.2 Hrs.

Mexico built vehicles:

Warranty Type	A
Symptom Code	60
Damage Code	9E
Part Number Main Cause / Qty.	BJS7-61-130F / 1
Operation Number / Labor Hours:	XXM67ARX / 3.6 Hrs.