



# 2017 Maserati Levante M161 Roadside Assistance Guide

# What is new?/Info



## 1. Air suspension – (pg.21)

All Levante models are equipped with an air suspension system with automatic level control and six different ride height levels.

## 2. Electronic Parking Brake (EPB) – (pg.17)

The Levante is equipped with a new generation Electric Parking Brake (EPB). This system has two electric motors on the rear brake calipers, and is no longer a cable type system.

## 3. Battery and door glass – (pg.13)

If the battery is completely discharged when the windows are fully raised, open the door carefully and DO NOT close the door again until it is possible to lower the window.

## 4. Collapsible spare tire – (pg.18)

An 18” spare wheel with collapsible tire is standard equipment. The tire must be inflated with the provided 12-volt compressor before driving the vehicle.

## 5. Power liftgate operation – (pg.9)

The power liftgate can be operated from five different locations. From inside on the front dome console, key fob, tailgate, trunk compartment and optional kick sensor.

## 6. Integrated Center Stack (ICS module) – (pg.4)

The Integrated Center Stack incorporates the HVAC control panel. The dual-knob rotary control is located in the center console and is used to make selections.

## 7. Entertainment Telematics Module (ETM) – (pg.4)

The touch screen and head unit run the Maserati Touch Control (MTC+) software which provides satellite navigation, smartphone interface, multimedia functions, and control for several vehicle functions.

# Table of contents

# M161



M161 Quick user guide -----	pg.4	Fuel/Fuel filling -----	pg.11	Vehicle lift points-----	pg.19
Dimensions and weight -----	pg.5	Towing of the Vehicle -----	pg.12	Important warnings and symbols-----	pg.20
Engine hood operation -----	pg.6	Battery Jump points (under hood) -----	pg.13	Suspension operations-----	pg.21
Engine component guide -----	pg.7	Battery location -----	pg.14	NOTES-----	pg.22
Vehicle ignition/ Remote keys -----	pg.8	Automatic transmission lever -----	pg.15		
Power liftgate operation -----	pg.9	Transmission park gear override -----	pg.16		
Levante tool kit -----	pg.10	Electronic Parking Brake (EPB) -----	pg.17		
		Collapsible spare tire -----	pg.18		

# M161 Quick user guide



## Transport to Mode

By using the Maserati touch screen you will need to follow the procedures below.

Turn on the Maserati Touch screen (MTC+) > Go to “settings” > use the scroll knob to highlight “Suspension”> then you will need to use the center bottom knob to scroll to “Transport mode”. This mode must be checked for “ON” prior to loading vehicle onto the flat bed and unchecked to “OFF” to arrival to destination.

## Tire Jack Mode

Using the same procedure from above you will need to use the scroll knob to highlight “Tire Jack mode” then press the “enter” button which will show the ✓ mark in the box confirming the suspension setting. The mode must be checked for “ON” before removing the wheel and unchecked to “OFF” before driving the vehicle.



## Electronic Parking Brake Release (EPB)

To release the EPB, the brake pedal must be fully pressed. Simply pull the lever located in the center command switches next to the rotary knob and the ride height selection rocker switch. The brake **BRAKE** indicator will show in red on the Instrument cluster, once the switch lever has been pulled the indicator light will disappear.



Entertainment Telematics Module (ETM)



Dual-knob rotary control for ICS



# Dimensions and weight



Dimensions	Mm	Inches
Length	5,003mm	196.9in
Width without mirrors	1,968mm	77.4in
Width with mirrors	2,158mm	84.9in
Height	1,679mm	66.1in
Wheelbase	3,004mm	118.2in
Front track	1,624mm	63.9in
Rear track	1,676mm	65.9in
Front overhang	966mm	38.0in
Rear overhang	1,033mm	40.6in
Ground Clearance	208mm	8.1in

Weights	Kg	lbs
Curb Weight	2,109kg	4,649lbs

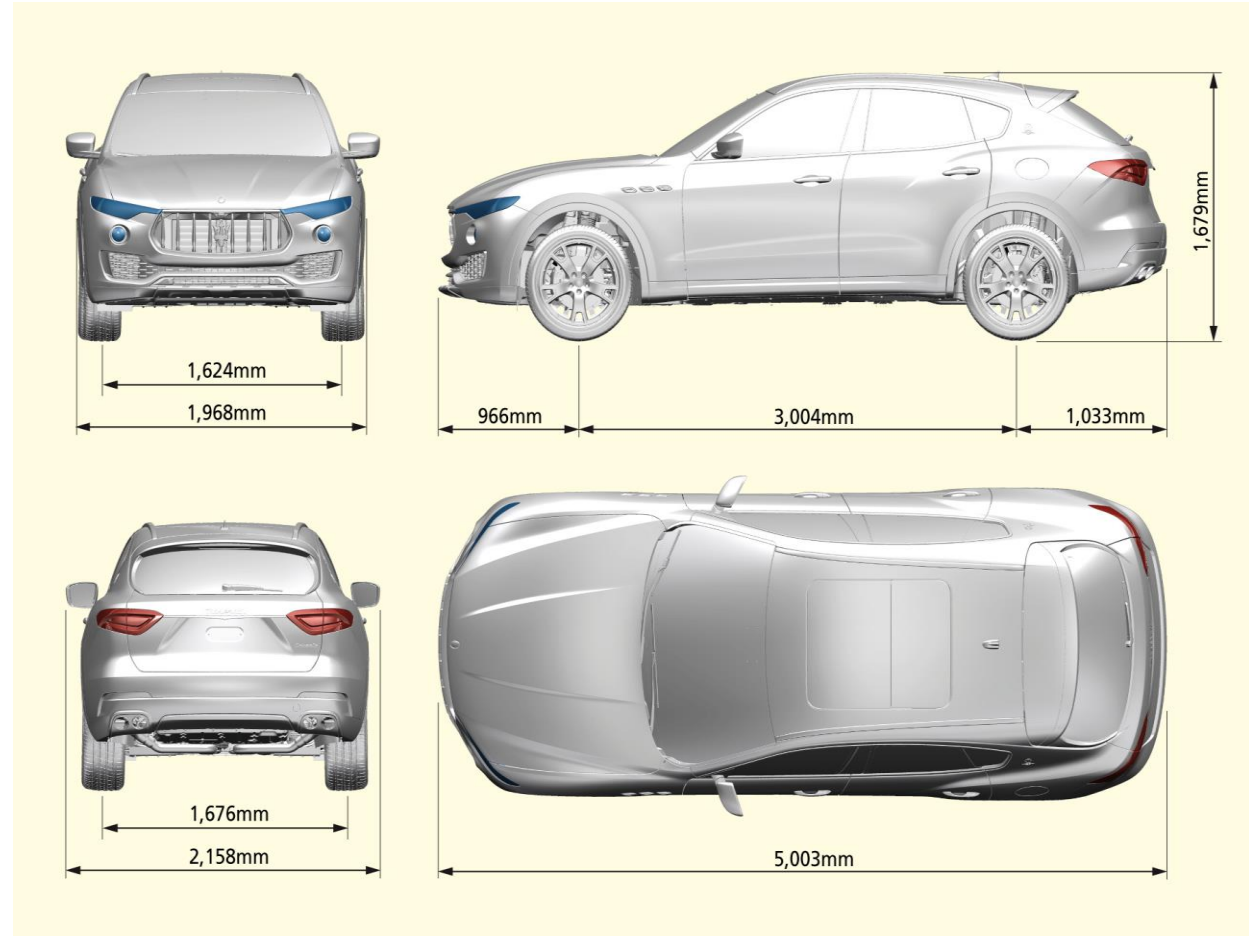

# Engine hood operation



## Opening

Two latches must be released to open the hood.

- From inside the vehicle, pull the hood release lever located on the drivers side under the dashboard.
- Slightly lift the hood and push the safety catch as indicated by the arrow. The safety catch is located in the center of the hood.
- Lift the hood completely: this operation is facilitated by two gas struts keeping the hood in the fully open position.



# Engine component guide

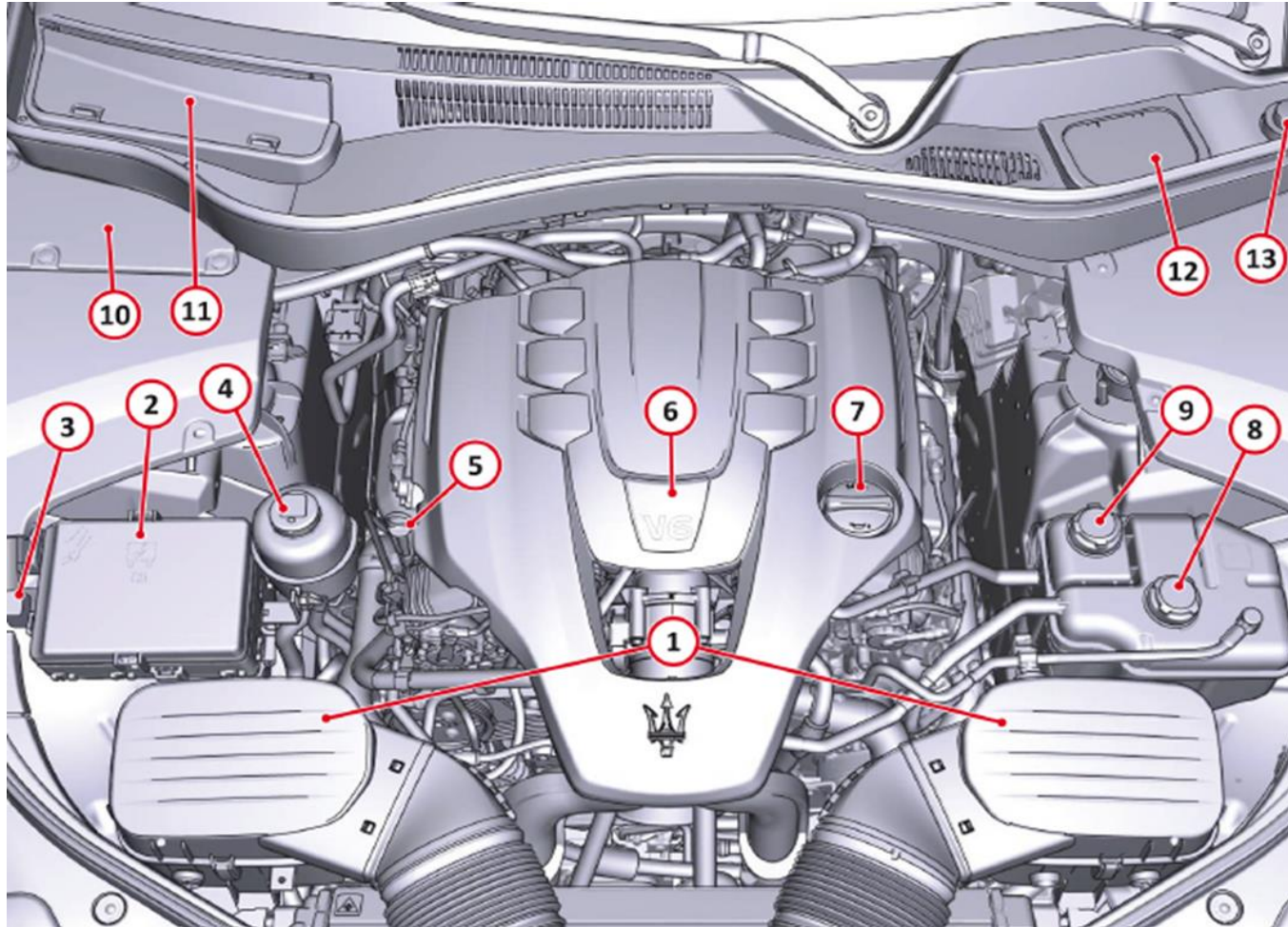

1. Air filter housing
2. Front Distribution Unit (FDU) housing fuses and relays
3. Engine compartment battery positive
4. Power steering fluid reservoir
5. Oil level dipstick
6. V6 logo: grey for the 350hp version and blue for the 430hp version
7. Oil filler cap
8. Reservoir for primary coolant circuit (engine cooling)
9. Reservoir for secondary coolant circuit (transmission and power steering cooling)
10. Cover for access to engine ECU (ECM)
11. Interior air filter cover
12. Brake fluid reservoir cover
13. Filling cap for windscreen washer fluid



# Vehicle ignition / Remote keys



The vehicle is equipped with a Remote Keyless Entry transmitter and a Keyless Ignition Node, to enter, start or disarm the alarm system.



## Keyless Ignition Device

Can operate the ignition switch with the push of a button, with Key inside vehicle.



The Keyless Ignition Node (KIN) has three operating setups indicated on the outer ring. Pressing and releasing the middle button, you can switch from one setup to the next without starting the engine, the switched on indication will turn amber.

The engine will start by pushing the center button **START/STOP** with the brake pedal pressed and the device set in any of the three operating setups.



In case the ignition switch does not operate by pushing a button, the RKE transmitter (key fob) may have a low or discharged battery. If this occurs it is necessary to replace the battery in order to operate the ignition switch. It is still possible to operate the ignition switch using the key fob RKE transmitter with discharged battery by pressing the nose side (side opposite of the emergency key) of the key fob on the **START/STOP** button. (shown in the picture above).



# Power liftgate operation

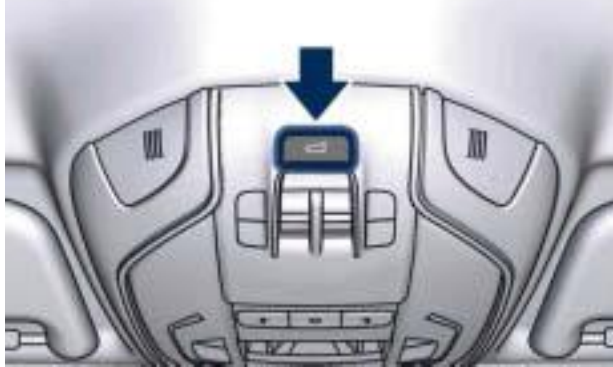

The power liftgate can be operated from inside the vehicle by pressing the button on the front dome console.

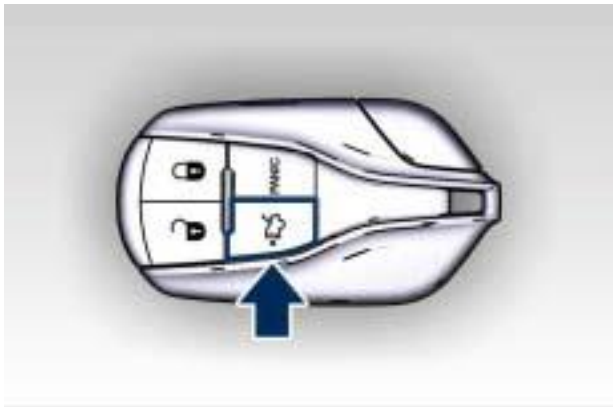

**NOTE: The shift lever must be in P (Park) before the Liftgate can operate.**

The power liftgate can be fully opened from outside the vehicle by pressing the button on the key fob.

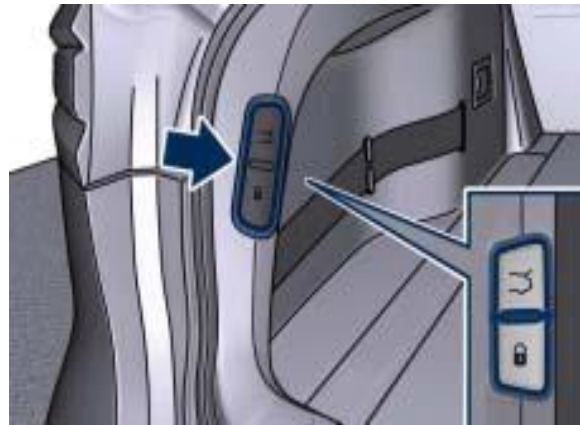

The buttons located on the outer edge of the left trunk compartment lining and indicated in the figure can be used to completely close and lock the power liftgate. Also external button located on the lower side of the liftgate ledge.

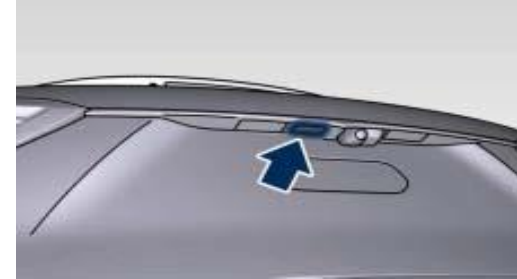

Power liftgate uses the button in-between the license plate lights, indicated in figure.

## Kick Sensor Option

The system will only operate if the system acknowledges the presence of the key fob RKE transmitter within 2.3 ft of the power liftgate. Do not place your foot too close to the bumper or touch the underbody. In order for the sensors to detect your foot movement, move your foot towards the vehicle rather than sideways and immediately pull it back: from this moment, the power liftgate will activate within two seconds.



**NOTE:** If your foot movement fails to activate the power liftgate movement, wiggling your foot under the bumper will not help. Repeat the whole kick movement. The power liftgate will be opened and closed only if the “Passive Entry” system acknowledges the presence of the key fob RKE transmitter.

# Levante tool kit



The tools located in the lower trunk area are the following:

Ref.	Description
1	Double torx + cross-head screw driver
2	Emergency tow hook
3	Electric compressor complete with pressure gauge for inflating the compact spare wheel
4	Extended wrench with rubber coated handle for unscrewing / tightening the wheel nuts
5	Adapter for wheel extended wrench
6	Jack set

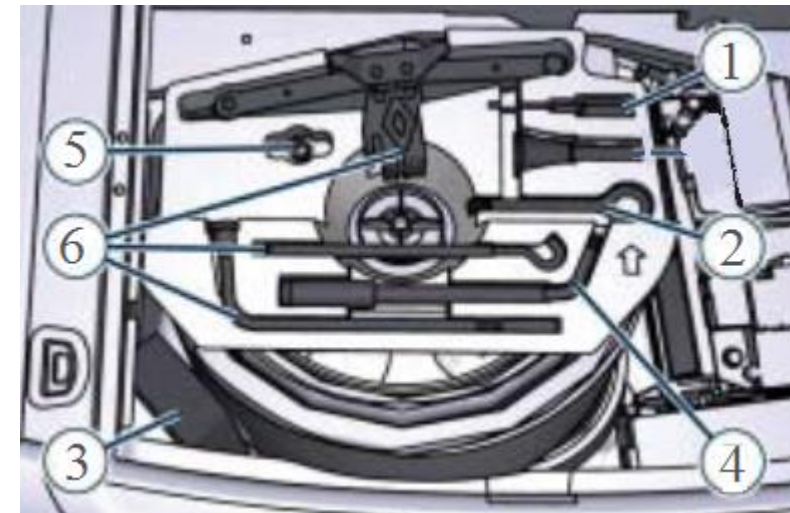

# Fuel / Fuel Filling



## Refueling

To access the fuel filler neck, the filler door must be unlocked. From outside the vehicle, this can only be done by pressing the unlock or the lock button on the key fob RKE transmitter, in the same way as if opening or closing the doors. If any of the door lock controls is pressed from inside the vehicle, the filler door will still remain unlocked to allow refueling.

Press the indicated area on the filler door, which is located on the rear drivers side of the vehicle: the filler door will open.



Fuel filler door

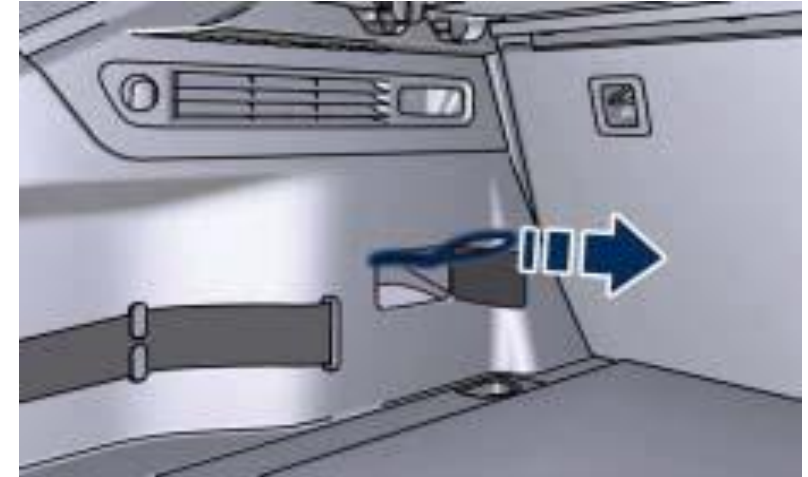

The fuel filler door emergency release located in the trunk



**NOTE: MUST use unleaded Premium gasoline with no less than 91 minimum octane rating or the check engine warning light may come on.**



# Towing of the vehicle



A screw-in type towing eye is provided with the vehicle. In case it is necessary to tow the vehicle, screw the towing eye completely into the towing eye attaching point. The Levante is equipped with two attaching points for the towing eye, one at the front and one at the rear. Make sure the following conditions are respected when the vehicle is to be towed:

- Engine off
- Ignition in "RUN"
- Electronic Parking Brake (EPB) disengaged (see pg.17)
- Gearbox in neutral position (see pg.16)
- Select "Transport mode" (see pg.21)

A disabled vehicle should be transported on a flatbed truck.

If a flatbed is not available, the vehicle can be towed with all four wheels on the ground.

NOTE: Maximum speed of 30 mph and a maximum distance of 30 miles must not be exceeded to avoid transmission damage.

NOTE: Never tow a disabled vehicle with its front wheels lifted. This will lead to damage of the transfer case due to insufficient lubrication. Never tow a disabled vehicle using a tow dolly for single axle towing.

WARNING! Must change air suspension setting to "Transport Mode" for loading and transport. (see pg.21)

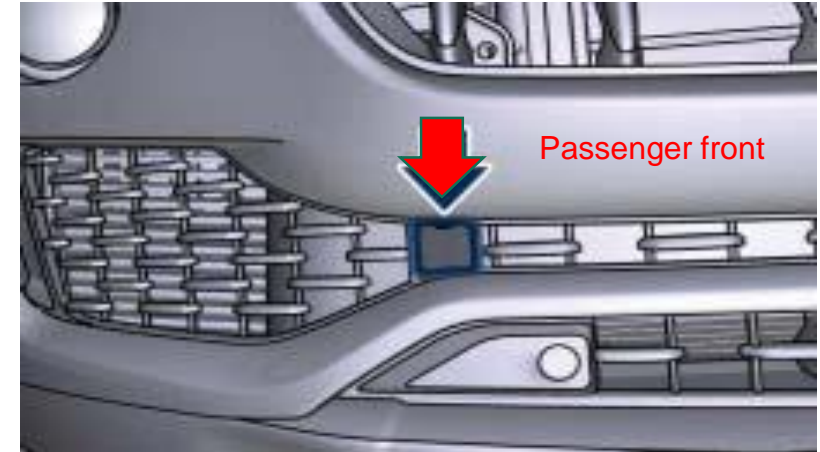

Attaching point for the towing eye is indicated by the arrows. The maximum work angle of the towing cable is 15°.

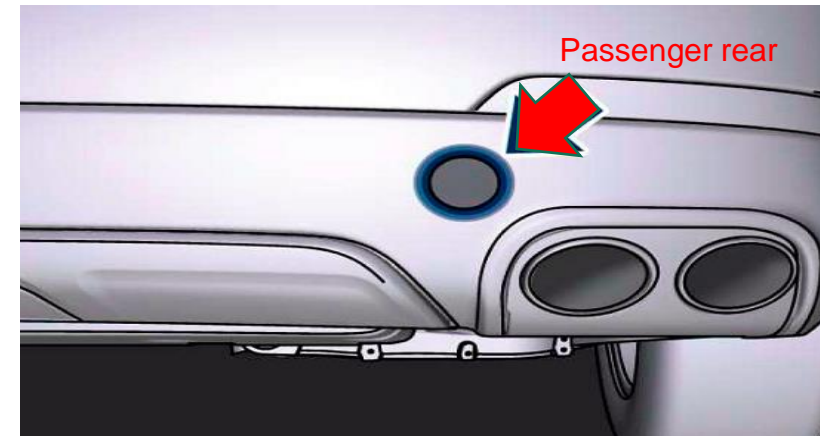



# Battery jump points (under hood)



Remote battery posts for jumpstarting are located in the engine compartment while the battery is stored in the passenger side of the luggage compartment.

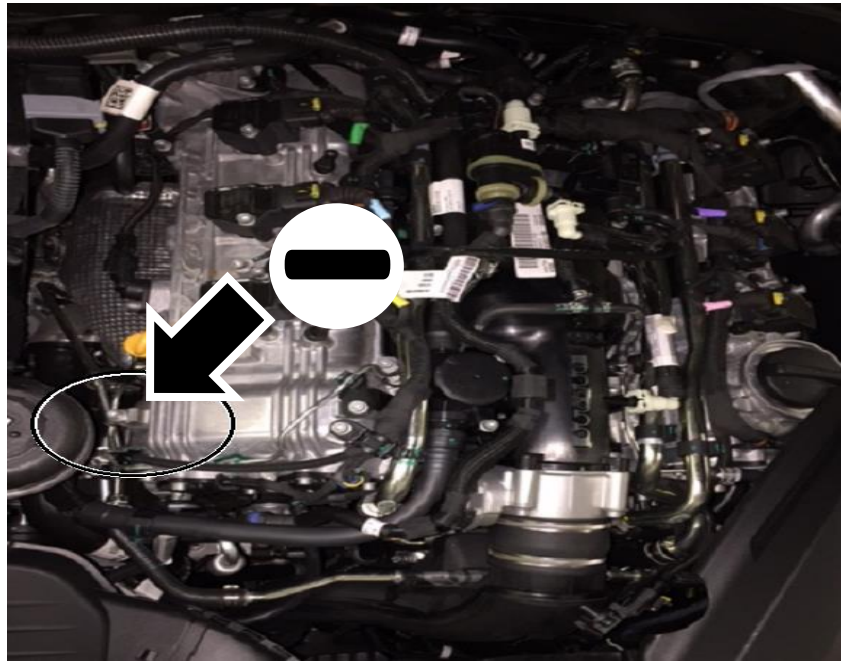

**(-)** Negative connection on engine must be attached to cylinder head cover

The positive remote post (+) is Located on the passenger side of the fuse box

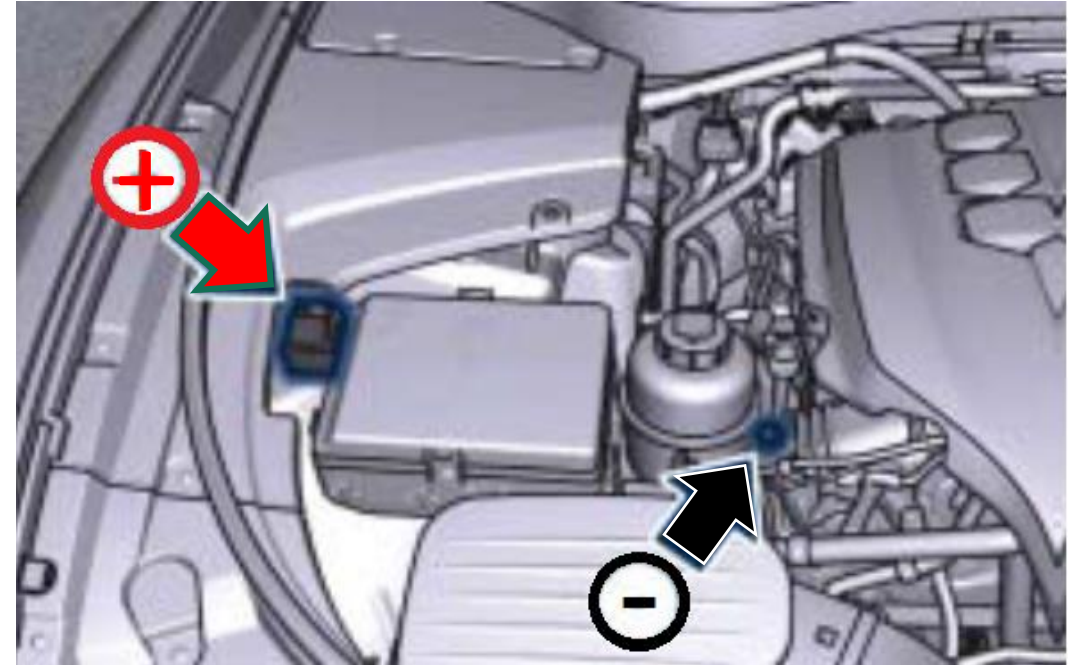

**NOTE:** If the battery is completely discharged when the windows are fully raised, open the door carefully. DO NOT close the door again until it is possible to lower the window.

# Battery location



Reminder: Remote battery terminals are located in the engine compartment for jump-starting.

For a successful charge/recharge operation, the charging current must flow through the IBS sensor as shown in the picture below.

The battery is an AGM 12V and is located in the passenger side luggage compartment floor.

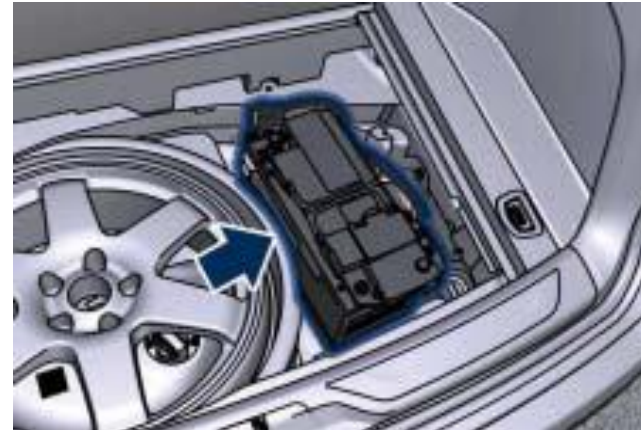
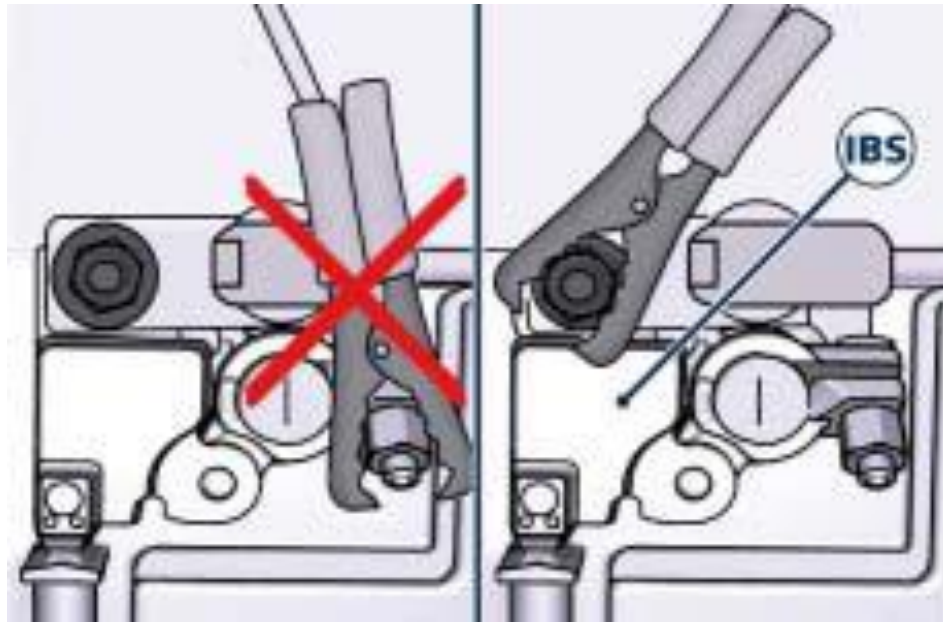

Right rear passenger trunk compartment

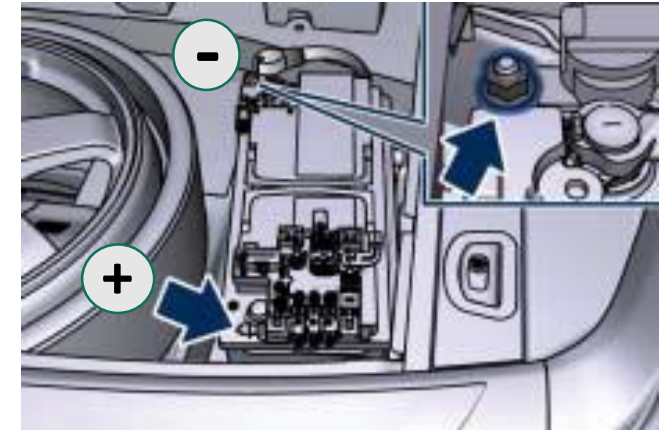

Battery points

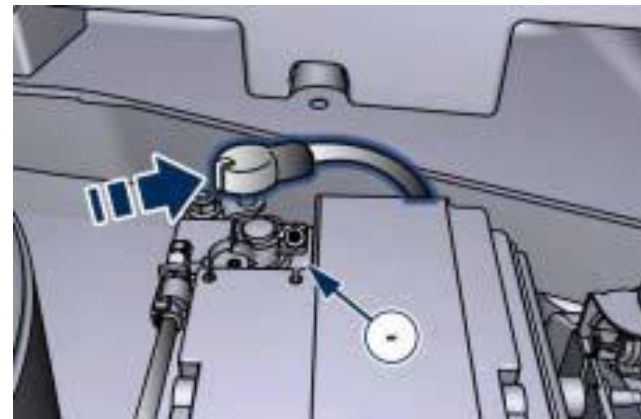

Battery ground quick release cable in trunk

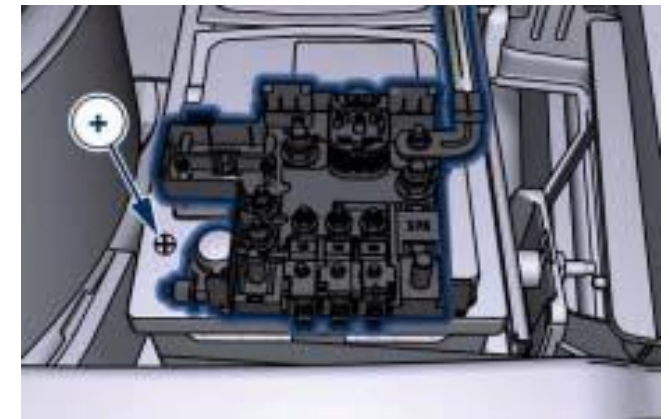

Positive battery terminal

**NOTE: Wait at least 30 seconds with the ignition switch turned to RUN before starting the engine.**



# Automatic transmission lever



Automatic transmission is operated by a selection lever with lock button located on the central console.

By using the selection lever it is possible to select the following positions, indicated on the top of the lever: the selected position will illuminate in amber light.

- P (Park);
- R (Reverse);
- N (Neutral);
- D (Drive) automatic forward speed (8 speeds)
- +/- to downshift or upshift when manual mode in D (Drive) status, or set to M (Manual) mode.

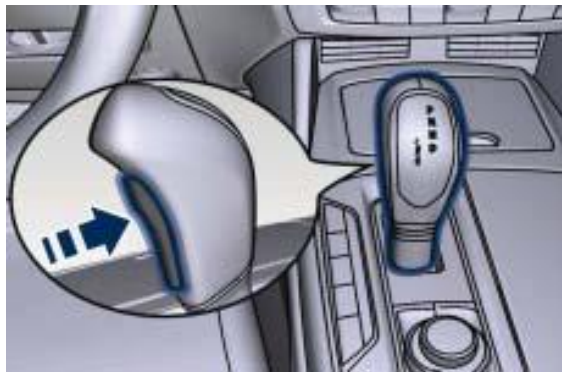

Transmission status is displayed on the shifter lever and on the lower part of the instrument cluster display.



By pressing the release button on the lever, the gear position field is displayed: if you release the button without moving the lever, the field disappears after 2 seconds. By operating the lever, the new range will be indicated in the field and in the lower part of the display.

## Automatic Transmission Range P (Park)

Use this position to park the vehicle. The transmission can be shifted out of P (Park) position only with the brake pedal pressed. To move the shift lever from P (Park) position to any other position, the engine must be switched on. The engine can be regularly started in P (Park) range. Never attempt to use P (Park) while the vehicle is in motion.



When parking on a hill, apply the parking brake before placing the shift lever in P (Park). (Shown in photo above)

# Transmission park gear override



In the event of a discharged battery or system failure, the park position of the gearbox can be released by pulling the cable. The release cable can be accessed by removing the cover in the carpet located in the lower left side of the driver's floor area.



**NOTE: This procedure is exclusively intended for emergency situations, only!**

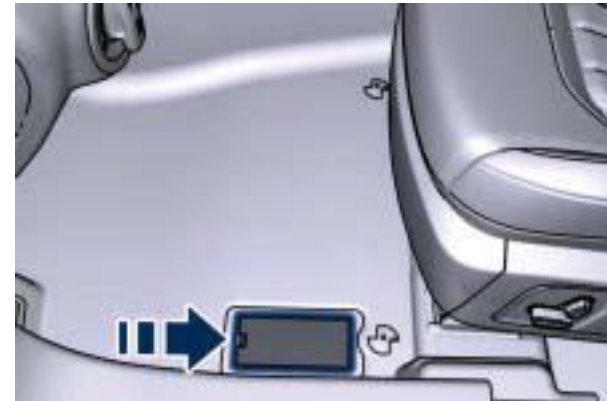

Lift the mat on the driver side to access the cover.

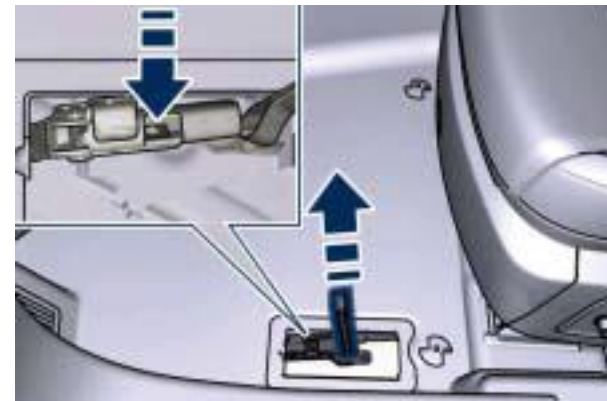



# Electronic Parking Brake (EPB)



The Levante is equipped with a new generation Electric Parking Brake (EPB). This system does not use a central cable puller unit but instead uses parking brake actuators integrated in the rear brake calipers. As a result, there is no manual release function for the parking brake. A parking brake failure requires service actions on the rear calipers which must be only performed in the workshop.

## EPB application and release

To release the EPB, the brake pedal must be pressed. In addition to manual operation, the following automatic strategies are also available:

- Auto-apply parking brake at key-off. This feature can be deactivated from the (IPC) Instrument panel cluster.
- Pre-release with engine running, driver's door closed, brake pedal pressed and shift lever moved to (D) or (R).
- Auto release at drive away (transmission in D or R, accelerator pressed over 3%).

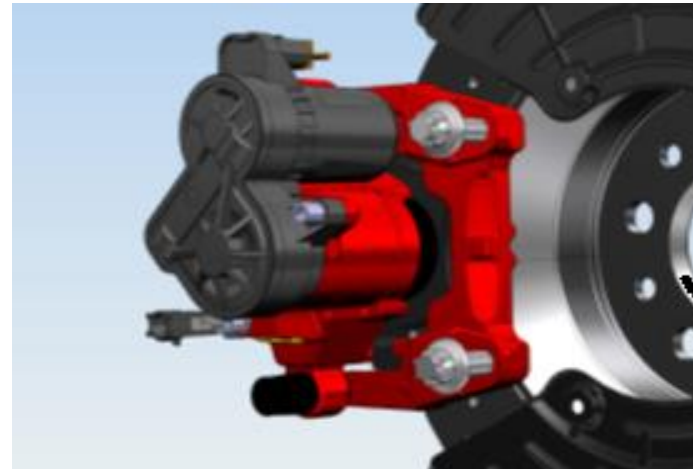

If the EPB cannot be released due to low battery voltage, it is necessary to connect an external power source to restore sufficient voltage. If an external source is not available, or if the nature of the fault is mechanical, the only remaining option is tow the vehicle. It is necessary to perform an EPB cycle (apply and release) after restoring the vehicle's battery voltage. ( Follow messages on Instrument cluster).

**NOTE: If the (EPB) cannot be disengaged the vehicle has to be towed, roller dollies must be used to move the vehicle onto a flatbed tow truck.**

# Collapsible spare tire



An 18" spare wheel with collapsible tire is available as standard equipment. **The tire must be inflated with the provided 12-volt compressor before driving the vehicle.**

The maximum allowable driving speed is limited to 45 mph and total maximum mileage driven on the spare wheel is 1,800 miles. After 1,800 miles total the spare wheel must be replaced.

Mounting the spare tire affects vehicle handling. Replace the original equipment tire as soon as possible and reinstall it on the vehicle. Do not install more than one compact spare tire on the vehicle at a time.

The kit consists of a 12-volt compressor, and an air hose. Once the collapsible spare tire installed, the vehicle can be driven for 12 miles at a maximum speed of 45 mph. After driving 6 miles a re-check is required, and the inflation procedure must be repeated.



**You must set the self-levelling system to the “Tire Jack mode” in the MTC+ Touch control screen (see pg.21)**

# Vehicle lift points



## Lifting and jacking



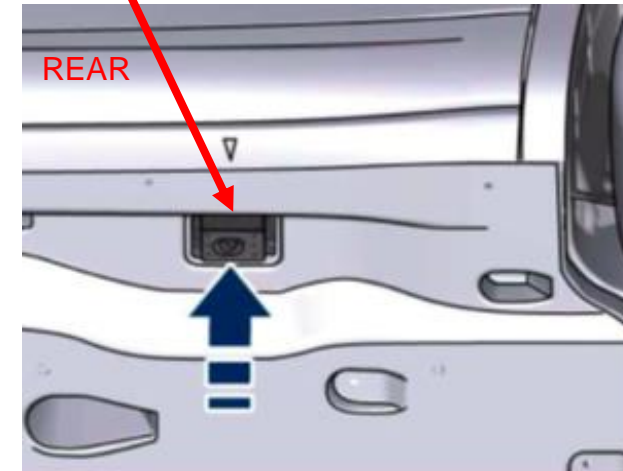
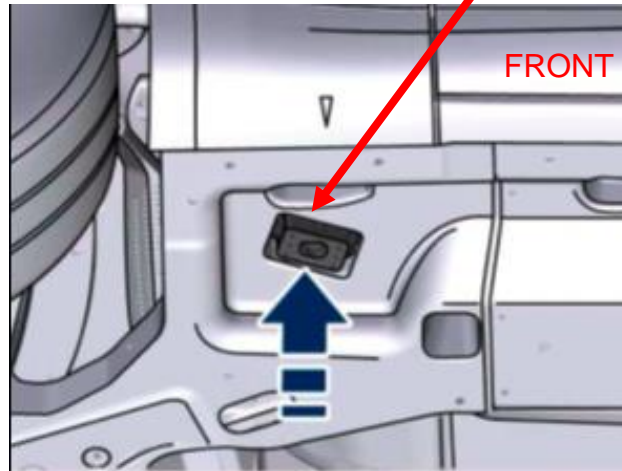
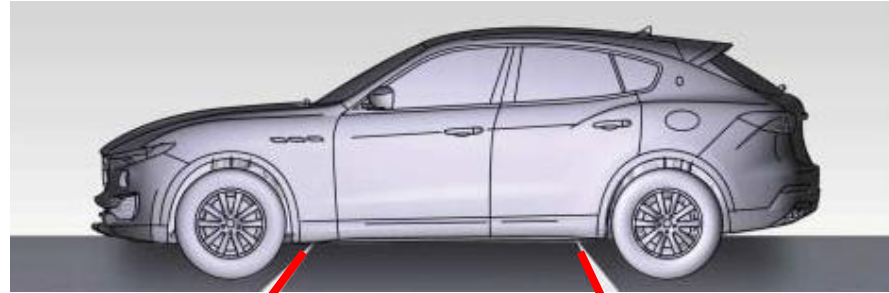

























Designated jack points allow for vehicle jacking and lifting without risk of damage to its underside. Use only these points to lift or to jack the vehicle.



To jack the car, it is necessary to first set the automatic level control function of the air suspensions system. Select the "Tire Jack mode" in the MTC+ menu. (see pg.36 for suspension operations)

# Important warnings and symbols



	Malfunction indicator (MIL)		Engine oil temperature warning		Windshield and headlamp low fluid
	Tire Pressure Monitoring (TPMS)		Low Engine oil level warning		Low fuel indicator
	Anti-lock braking system (ABS)		Power steering failure warning		Ice Hazard Indicator Light
	Electronic Stability Control (ESC) Activation/Malfunction Indicator		Catalyst Over Temperature Warning		Fuel Filler Cap (Gas cap) Open
	Start & Stop Active Indicator		Liftgate Ajar Indicator		Electric Parking Brake Failure
	Brake indicator/warning		Hood Ajar Indicator		Start&Stop disable Indicator
	Air Bag indicator		Door Ajar Indicator		Start&Stop Failure Warning
	Seat belt reminder		Suspension failure warning		Forward Collision Warning (FCW) Fault (If equipped)
	Scheduled Maintenance (Service) Indicator		Adaptive cruise control		AWD system warning/failure
					Lane Departure Warning (LDW) Fault (if equipped)



# Suspension operations



## Tire Jack Mode

When lifting or jacking to replace a wheel, you must set the levelling system to the “Tire Jack mode”. In the MTC+ Touch control screen “Settings” menu, ensure the check is shown in the BOX.

Select this mode to change the air suspension settings when the vehicle is lifted for changing a wheel or tire.

The mode must be checked for “ON” before removing the wheel and unchecked to set to “OFF” before driving the vehicle.



The air suspension system is equipped with a specific mode to be used when vehicle must be lifted to change one or several wheels/tires. This mode temporarily prevents the air suspension system from automatic leveling. To activate this mode, scroll user settings on MTC+ and select “Tire Jack Mode” in submenu “Suspension”. The check next to the selected item will indicate that this mode is set and the vehicle is ready for servicing. To restore original setting, eliminate the check next to the selected mode. The air suspension system will return to normal operation.



## Transport Mode

Select this mode to lower the air suspension to minimum ride height and change the system operation during vehicle loading and transport on the flatbed tow truck. This mode must be checked for “ON” prior to loading vehicle on to the flat bed and unchecked to set to “OFF” after arrival to destination.





# NOTES

# M161

A large, empty rectangular box with a thin black border, intended for handwritten notes.