



Maserati Technical Bulletin

Date: July 15th, 2016
Bulletin No. MAS000903/A - Front Suspension
Spring Replacement
Service Campaign - 306
Supersedes: MAS000903

MASERATI

MODEL: Maserati Quattroporte (M156) and Ghibli (M157)

MODEL YEAR: 2014-2015

SUBJECT: Front Suspension Spring Replacement – Service Campaign 306

DESCRIPTION

Maserati Quattroporte (M156) and Ghibli (M157) vehicles are involved in a Service Campaign to replace the Front Suspension Springs to help improve the ride and comfort quality in any drive condition, especially on rough road surfaces. .

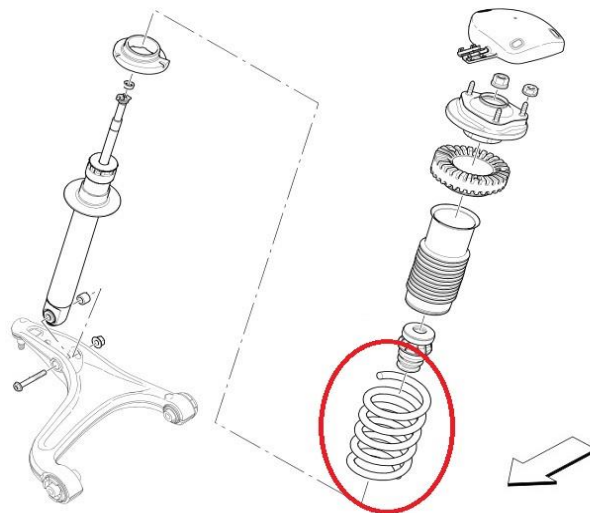

IMPORTANT NOTES

For efficiency and customer satisfaction purposes, **this campaign must be performed together with the “Dome reinforcement plates installation – Service Campaign 268”**.

The time for the springs replacement will be reimbursed through Campaign 268 while the spare parts and the time for the warranty claim submission into ModisCS+ will be reimbursed through this Campaign number 306.

If the “Dome reinforcement plates installation – Campaign 268” has already been performed, the Dealer is allowed to claim the time for the springs replacement through this Campaign number 306.

PARTS NEEDED FOR THE REPAIR

For this campaign, the front suspension springs have to be ordered from the Maserati Parts Dept. Please order two springs for each vehicle. When looking up the part number in the Parts Catalog (left side below), use the Campaign Spring P/N (right side below).

Parts Catalog P/N → Campaign 306 P/N

673002043	→	673006849
673002077	→	673006850
673004064	→	673006851
673004065	→	673006852
673004068	→	673006853

NOTE: Please check your inventory prior to ordering any parts. Each dealer was shipped an allocation of parts based on the number of vehicles impacted by this Campaign.

OPERATING PROCEDURE

1. Check if the vehicle is involved in this campaign and if the campaign has not been previously performed.
2. Replace the two front suspension springs as shown in Section 6.11.009 – 00 and 6.11.010 – 00 of the Workshop Manual.
3. The procedure is completed.

Warranty Information

- Campaign Number 306
- Warranty Code 23
- Defect Code 063
- Component Code 6.11.009
- Operation Code for warranty claim submission 6.11.009.9 (0.05h)

Operation Code for front suspension springs replacement – **To be used only if Campaign 268 has been previously performed** 6.11.009.8 (2.5h)

- Component Part Number See parts section

Nicola Rosciano
 Manager Technical Support
 Maserati North America, Inc.

Luis Sanchez
 Technical Director
 Maserati North America, Inc.