

ATTENTION:

- GENERAL MANAGER
- PARTS MANAGER
- CLAIMS PERSONNEL
- SERVICE MANAGER

IMPORTANT - All Service Personnel Should Read and Initial in the boxes provided, right.

© 2014 Subaru of America, Inc. All rights reserved.



QUALITY DRIVEN® SERVICE

SERVICE BULLETIN

APPLICABILITY: 2014-15MY XV Crosstrek Hybrid Electric Vehicle (HEV) **NUMBER:** 16-94-15R

SUBJECT: Diagnosis and Repair of DTCs P172A and P0B0B

DATE: 07/30/15

REVISED: 08/12/16

INTRODUCTION

This bulletin provides a diagnosis and repair procedure for DTC P172A and / or P0B0B. When either of these DTCs is stored, a leaking o-ring which seals the electric oil pump relief valve may allow CVT fluid to enter the pump's electric motor. Although current Service Manual diagnostic procedures instruct replacement of multiple components, this information will help isolate the actual failed component for a more cost-effective repair.

PRODUCTION CHANGE INFORMATION

A change to the drive motor relief valve o-ring was incorporated into production on June 16, 2015 starting with VIN F*298545.

ADDITIONAL TOOLS REQUIRED:

- Digital Voltage / Ohm Meter (DVOM) with test leads (1000v, CAT III)
- ¼" drive T-25 or T-30 TORX® bit for battery cover screws
- Electrical tape to insulate power cable terminal ends (3- 2" long pieces of tape)
- Personal Protective Equipment (Hybrid Safety Kit J-51311, **ALWAYS** check the Expiration Date on Gloves)

DIAGNOSIS PROCEDURE / INFORMATION:

VERY IMPORTANT SAFETY WARNING: The HEV system includes a high-voltage circuit. Mishandling of HEV-related components may cause electric shock and serious personal injury. Technicians who have not received Subaru Hybrid training should NOT perform testing or repairs related to the HEV system. ****See Subaru Technician Reference Booklet, Module 702 (MSA5P1702C) for more HEV information.**

NOTE: Before starting the diagnosis procedure, use the SSMIII to confirm CVT fluid temperature is below 104 degrees F (40 C).

IMPORTANT: The next steps require Personal Protective Equipment be worn.

- Remove the rear cargo area floor mat and the sub-trunk (storage tray).
- Remove the orange HEV Service Disconnect plug and put it in your pocket.
- Remove the TORX screws and necessary trim clips securing the aluminum battery cover.
- **ONE AT A TIME**, remove the 3 bolts securing the orange "W", "V", and "U" cables to the electric oil pump inverter. As each cable is removed, cover each terminal end with one piece of electrical tape to insulate it. Connect the RED (+) test lead from the DVOM to the "U" cable end and BLACK (-) lead to the "V" cable end as shown. Confirm the "W" cable end is wrapped with insulating tape.

Continued...

CAUTION: VEHICLE SERVICING PERFORMED BY UNTRAINED PERSONS COULD RESULT IN SERIOUS INJURY TO THOSE PERSONS OR TO OTHERS.

Subaru Service Bulletins are intended for use by professional technicians ONLY. They are written to inform those technicians of conditions that may occur in some vehicles, or to provide information that could assist in the proper servicing of the vehicle. Properly trained technicians have the equipment, tools, safety instructions, and know-how to do the job correctly and safely. If a condition is described, DO NOT assume that this Service Bulletin applies to your vehicle, or that your vehicle will have that condition.

SUBARU OF AMERICA, INC. IS ISO 14001 COMPLIANT

ISO 14001 is the international standard for excellence in Environmental Management Systems. Please recycle or dispose of automotive products in a manner that is friendly to our environment and in accordance with all local, state and federal laws and regulations.

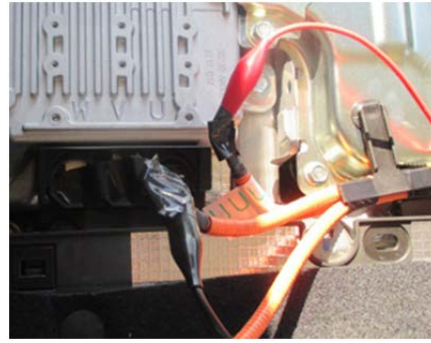

- Reinstall the orange HEV Service Disconnect plug.
- Turn on the DVOM and set it to measure AC Voltage.
- Start the engine and with the transmission in PARK, hold the engine at 1800 RPM.
- Read the AC voltage on the DVOM display and record your result.

NOTES:

- The AT TEMP lamp will stay on because at this point, the power cables to the inverter are removed.
- Confirm the DVOM is properly set so it can measure and display the correct AC voltage (e.g. select 1000 VAC or “Auto Range” depending on the DVOM being used).

IF THE DVOM SHOWS 0.5V OR MORE: the o-ring and drive motor are damaged. The drive motor / case assembly must be replaced. Remove the CVT assembly following the procedure in the applicable Service Manual.

IF THE DVOM SHOWS LESS THAN 0.5V: the root cause of the DTC is elsewhere. Continue with the DTC diagnostic procedure in the applicable Service Manual.

IMPORTANT: The next steps also require Personal Protective Equipment be worn.

REMINDER: Remove the (orange) Hybrid Service Disconnect plug again and put it in your pocket **BEFORE** reconnecting the Oil Pump Inverter power cables.

- Re-connect the inverter power cables **ONE AT A TIME** and torque the 10mm bolts to 5.5 ft. lbs.
- Replace the battery cover and torque the TORX screws to 5.5 ft. lbs.
- Reinstall the sub-trunk and rear cargo area floor mat.
- Reinstall the orange HEV Service Disconnect plug.

Required Parts List for Drive Motor Case Assembly Replacement:

PART NUMBER	DESCRIPTION	QTY.
SOA635304*	CVTFII Fluid	13
K0877YA020	ThreeBond 1217B (Pink)	1
004403007	ThreeBond 1215 (Gray)	1
806911080	O Ring	1
29019AA001	Case Assembly-Motor	1
31325KA151	Bolt Assembly-Seal	2
31759AA060	Clip-Transmission Harness	1
31377AA600	Ring-Seal	2

*Warranty Claim Part Number (Not Orderable)

Continued...

PART NUMBER	DESCRIPTION	QTY.
33295AA000	Gasket	1
806912200	O Ring	5
806912210	O Ring	1
806917100	O Ring	2
806929070	O Ring	1
99079AA100	Hose-ATF	1
99079AA110	Hose-ATF	1
28333AG010	Circlip-CVJ	2
806735300	Oil Seal	1
806735290	Oil Seal	1
31377AA490	Ring Seal	1
31377AA590	Ring Seal	2
806913250	O Ring	1

REPAIR PROCEDURE:

- Remove the CVT assembly following the procedure outlined in the applicable Service Manual.
- **CAREFULLY** remove the sensor cover, disconnect the wiring harness connectors and remove the transmission harness as necessary to facilitate removal of the extension housing and drive motor case assembly from the CVT main case. **See: “38. Drive Motor Assembly”** in the applicable Service Manual on STIS.
- Remove the electric oil pump assembly, output clutch control valve body, power connect cover and the secondary pressure sensor from the old drive motor case assembly.

NOTES:

The bulk of this procedure is best performed with the transmission assembly standing vertically. Use the 4- 6M/T stands (S/T# 18632AA000) pictured below for support.



- The torque converter can also be left in place. Either support it from the underside after standing the unit up with a block of wood or use a retainer strap / bracket included with remanufactured and replacement transmission assemblies to keep the torque converter in place.



Continued...

- It is **NOT** necessary to remove the internal parking pawl control rod or the inhibitor switch assembly to perform this repair.
- There are 14 bolts securing the drive motor case assembly to the CVT main case.
- Use extra caution during removal and installation of the electric oil pump wiring harness to avoid damaging it.
- Always utilize a helper when removing and installing the drive motor case assembly.
- The drive motor input shaft and coupling sleeve must be swapped over to the new Drive Motor Case assembly.

IMPORTANT: Before reassembling the cases, the following 3 measurements must be performed to determine the required thicknesses for:

1. Output clutch roller bearing shim (Note measurement of removed shim(s) here)
2. Transfer drive gear shim (Note measurement of removed shim(s) here)
3. Transfer driven gear shim (Note measurement of removed shim(s) here)

1. Output clutch roller bearing shim:

Steps 1 & 2:

1) Remove the output clutch assembly.

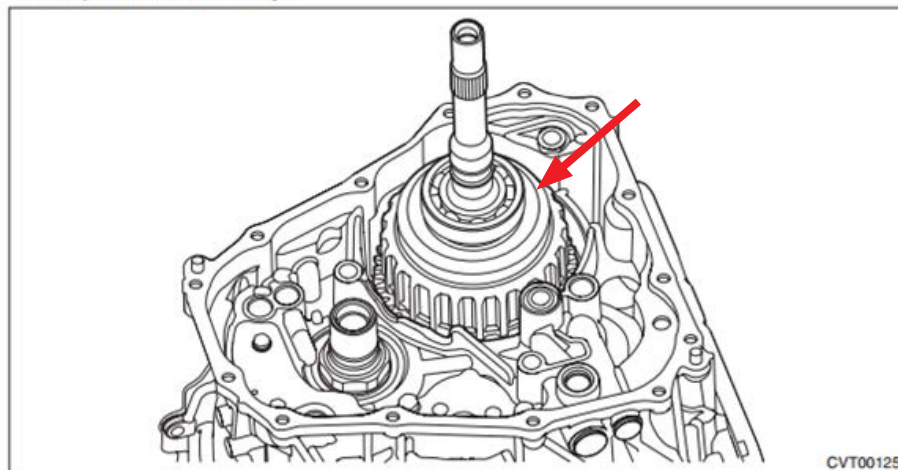

2) Measure the height "A" from the Gauge Block upper face to the ball bearing catch surface.

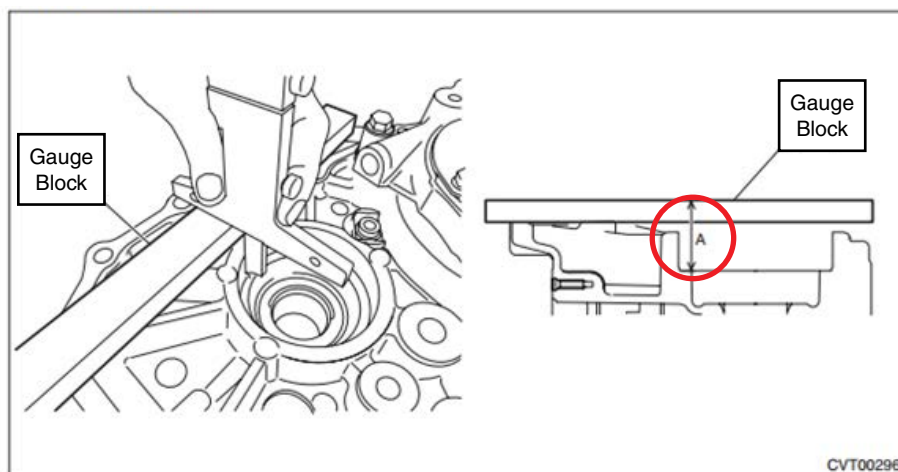

Continued...



Steps 3:

3) Reinstall the output clutch assembly then measure the height "B" from the Gauge Block to the mating surface of the transmission case.

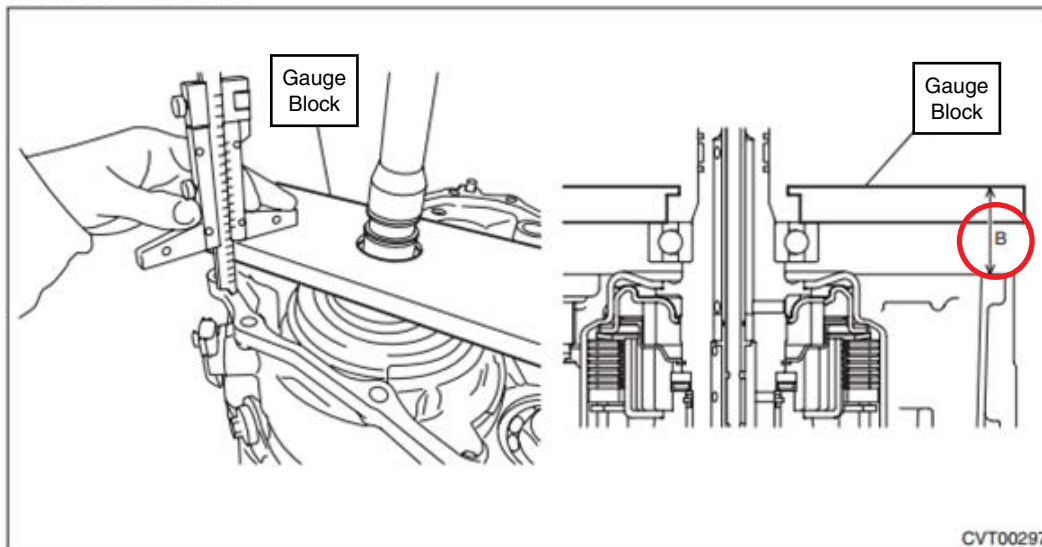

4) Obtain the thickness of reduction driven gear shim using the following formula to select zero to three reduction driven gear shims.

$$T \text{ (mm)} = A - B - (0.05 \text{ — } 0.25)$$

$$T \text{ (in)} = A - B - (0.002 \text{ — } 0.01)$$

T: Shim thickness

A: Height from the Gauge Block upper face to the ball bearing catch surface

B: Height from Gauge Block to transmission case mating surface

0.05 — 0.25 mm (0.002 — 0.01 in): Clearance

Reduction driven gear shim	
Part No.	Thickness mm (in)
33279AA090	0.3 (0.012)
33279AA100	0.4 (0.016)
33279AA110	0.5 (0.020)

Continued...

2. Transfer drive gear shim:

Step 1:

1) Measure the height "A" from the Gauge Block upper face to the ball bearing catch surface.

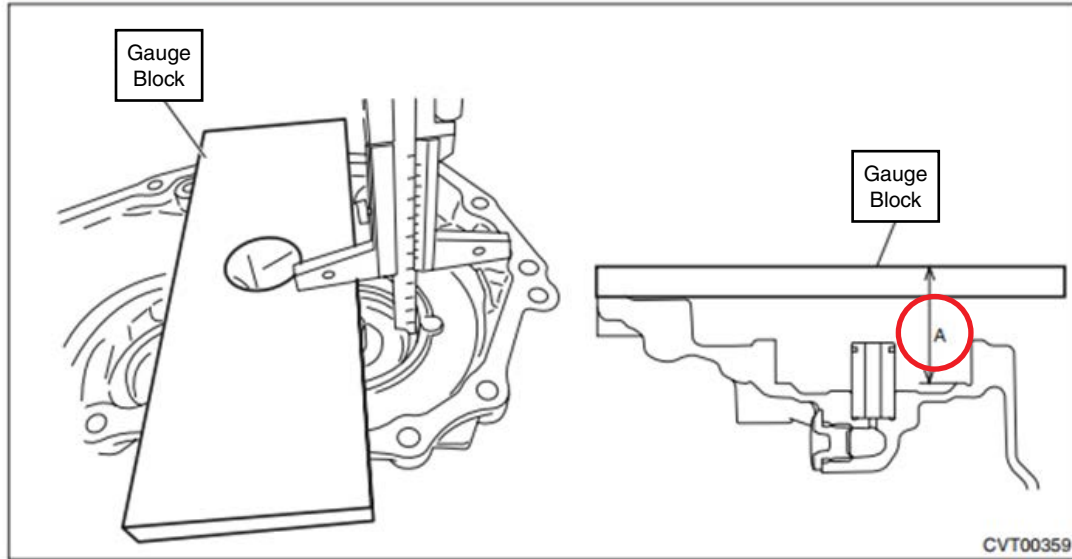

Steps 2 and 3:

2) Measure the height "B" from the Gauge Block to the mating surface of the transmission case.

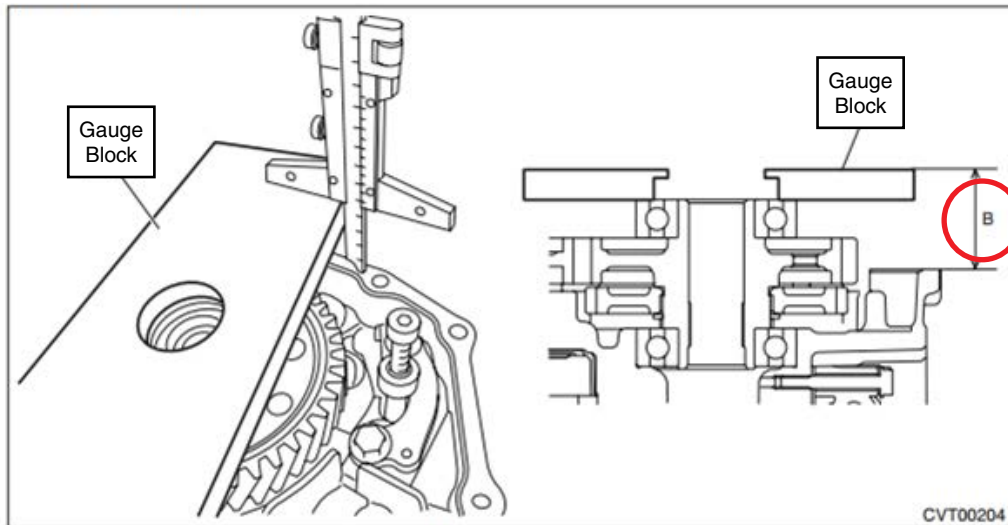

3) Obtain the thickness of transfer driven gear shim using the following formula to select zero to three transfer driven gear shims.

$$T \text{ (mm)} = A - B - (0.05 - 0.25)$$

$$T \text{ (in)} = A - B - (0.002 - 0.01)$$

T: Shim thickness

A: Height from the Gauge Block upper face to the ball bearing catch surface

B: Height from Gauge Block to transmission case mating surface

0.05 — 0.25 mm (0.002 — 0.01 in): Clearance

Transfer drive gear shim	
Part No.	Thickness mm (in)
33279AA090	0.3 (0.012)
33279AA100	0.4 (0.016)
33279AA110	0.5 (0.020)

Continued...

3. Transfer driven gear shim:

Step 1:

1) Install the transfer clutch assembly to the extension case with the transfer driven gear shims and thrust bearings removed.

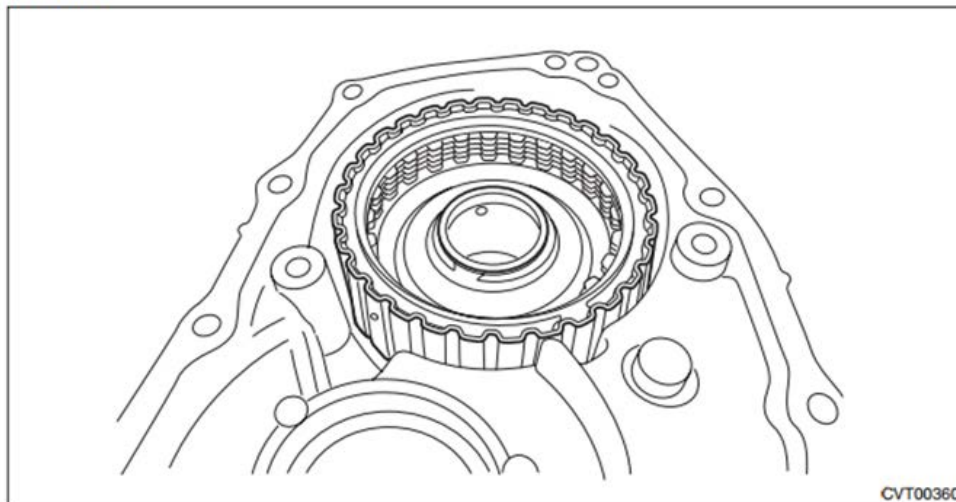

Steps 2, 3, 4, and 5:

2) Install the thrust bearing to the transfer driven gear.

NOTE:

Make sure to install in the right direction.

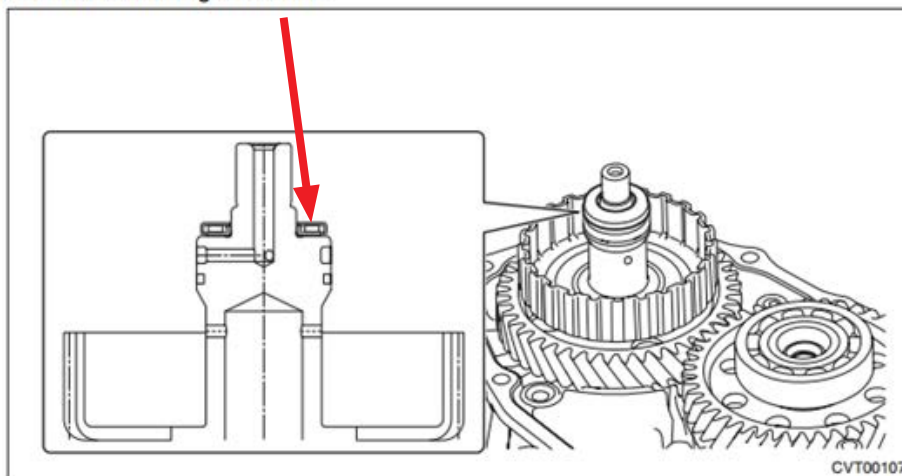

3) Using the Gauge Block, measure the height "A" from the ST end face to the thrust bearing catch surface of the transfer clutch assembly.

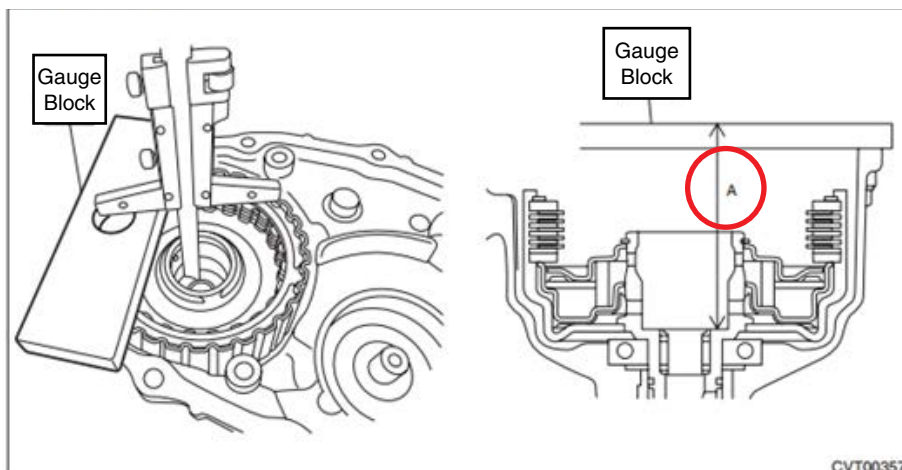

Continued...

4) Using the Gauge Block, measure the height “B” from the transmission case mating surface to the end of the Gauge Block

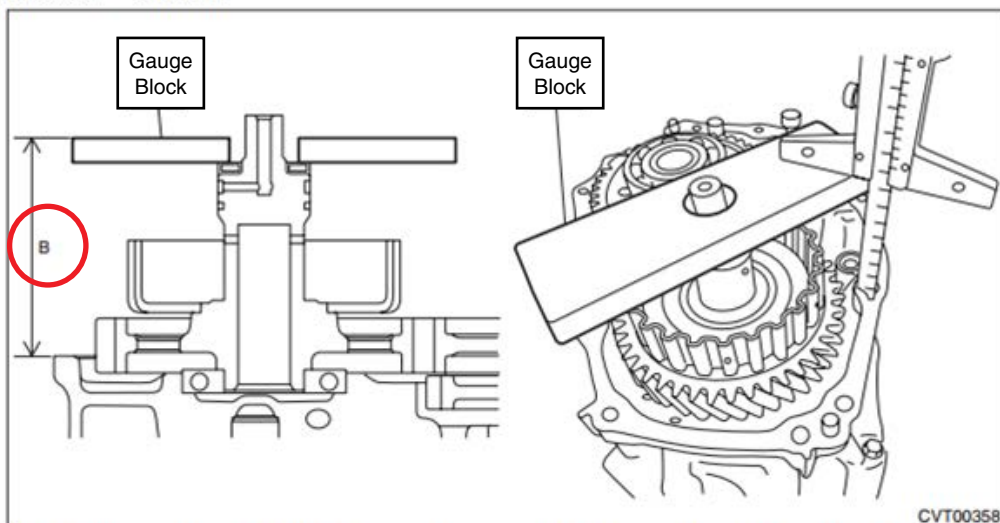

5) Obtain the thickness of transfer driven gear shim using the following formula to select zero to three transfer driven gear shims.

$$T \text{ (mm)} = A - B - (0.05 \text{ — } 0.25)$$

$$T \text{ (in)} = A - B - (0.002 \text{ — } 0.01)$$

T: Shim thickness

A: Height from the Gauge Block end face to the transfer clutch assembly thrust bearing catch surface

B: Height from mating surface of the transmission case to the end of the Gauge Block

0.05 — 0.25 mm (0.002 — 0.01 in): Clearance

Transfer driven gear shim	
Part No.	Thickness mm (in)
33280AA060	0.3 (0.012)
33280AA070	0.4 (0.016)
33280AA080	0.5 (0.020)



Once all of the proper shim thicknesses have been determined, proceed with reassembly following the procedure outlined in the applicable Service Manual.

Continued...

REASSEMBLY NOTES:

- When installing the secondary pressure sensor and inspection plugs, **ALWAYS** install a new o-ring (with some CVT fluid applied to it) and follow the proper torque specifications as they do vary.
- Remember to transfer both of the oil baffles shown below over to the new assembly.



- Never expand the output clutch output shaft interlocked split sealing rings any more than necessary to get them onto the shaft. Use caution and patience as they can be tricky to install. **NOTE:** If these sealing rings become deformed during installation, they **MUST** be replaced.

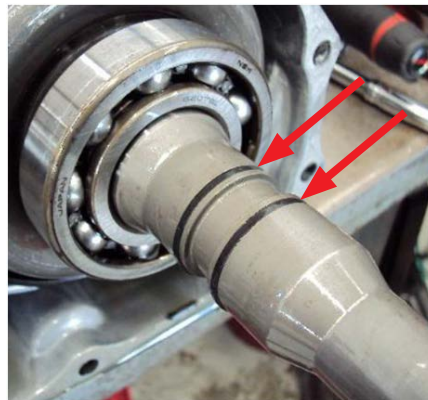

IMPORTANT: BEFORE applying any sealer to the cases, always trial fit them together to confirm proper spline alignment between the coupling sleeve, the drive motor input shaft and the primary pulley. The cases are too close together to facilitate turning the primary pulley retaining nut to get the splines aligned properly, especially when there is fresh sealer applied.

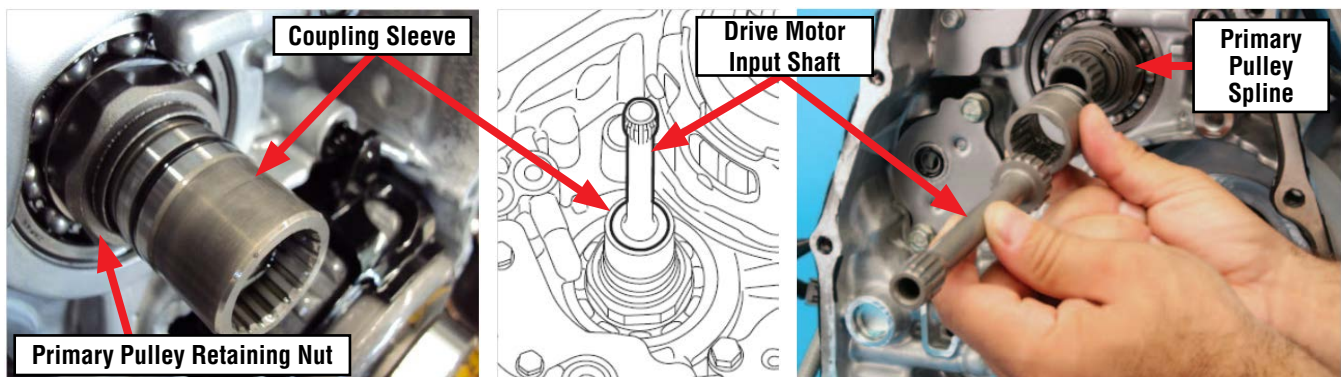

Continued...

- Once proper spline alignment is confirmed, use some CVT fluid to hold the 6 o-rings in place between the cases during reassembly.

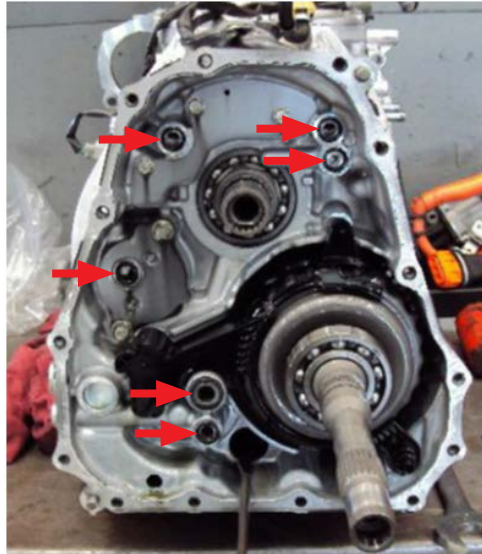

- Use the **GRAY** ThreeBond sealer (004403007) to seal the case assemblies and the **PINK** (K0877YA020) sealer for the small output clutch control valve body fluid pan.
- Torque the 14 case bolts to 18.4 ft. lbs.
- Never twist the electric oil pump harness more than 360 degrees to avoid damaging it.

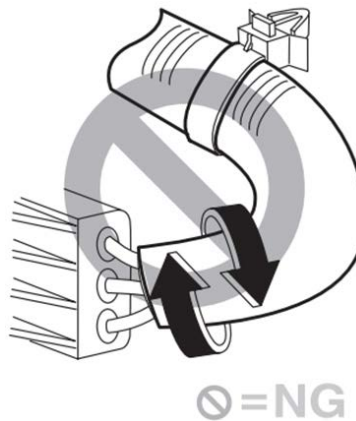

WARRANTY / CLAIM INFORMATION:

For vehicles within the Basic New Car Limited or Powertrain Warranty period or vehicles with an active Added Security Classic, Gold or Powertrain plan, this repair may be claimed using the following information:

LABOR DESCRIPTION	LABOR OPERATION #	FAIL CODE	LABOR TIME
HEV DRIVE MOTOR ASSY. R&R	B302001	MTO-42	4.8
REPLACE DRIVE MOTOR ASSY.	C302003		1.2
HEV TESTING & DIAGNOSIS	C800201		.5

REMINDER: SOA strongly discourages the printing and/or local storage of service information as previously released information and electronic publications may be updated at any time.

Always refer to STIS for the latest service information before performing any repairs.