



Team Tips

ARTICLE: I-16-03-01

DATE: 03/23/2016

Published for Indian Motorcycle Dealerships, Distributors, and Service Technicians

SUBJECT: Indian Full-Size Motorcycles – Fuel Pump Service Information

PURPOSE:

Indian Motorcycle has implemented an updated, maintenance-free fuel pump assembly for all full size Indian motorcycles produced from November 11, 2015. The updated fuel pump is a direct replacement for the previous version and does not affect fuel pump removal or installation procedures.

IMPORTANT SERVICE NOTES:

- The updated fuel pump assembly (PN:2521632) has a white pump housing. The previous fuel pump assembly (PN:2521305) has a black pump housing.
- The updated fuel pump assembly does not have a replaceable filter element and does not require routine maintenance. The service life of the updated fuel pump is intended to exceed that of the previous pump. Refer to Service Manual for fuel pump replacement and specifications.
- Replacement fuel filters for fuel pump (2521305) will remain available for purchase through normal channels.
- Orders placed for fuel pump PN:2521305 will supersede to PN:2521632.

FUEL PUMP (2521305)

Production through 11/10/2015

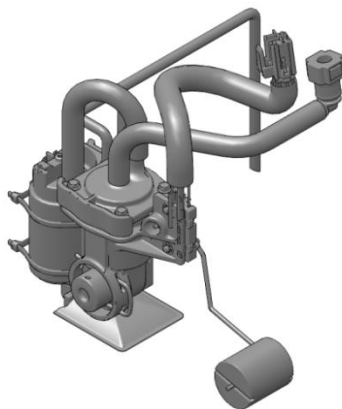

-50,000 mile fuel filter service pump

UPDATED FUEL PUMP (2521632)

Production from 11/11/2015

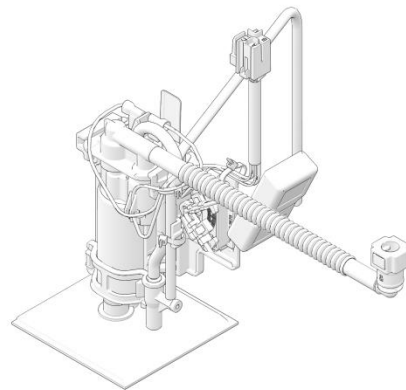

-Extended life, maintenance-free pump