

Front License Plate & Mounting Bracket Installation

Service Category General

Section Pre-Delivery Service

Market USA

Lexus Supports
ASE Certification 

Applicability

YEAR(S)	MODEL(S)	ADDITIONAL INFORMATION
2016	RC F, RC200T, RC300, RC350	

Introduction

The front license plate mounting bracket and two self-tapping screws for the 2016 model year RC 200t/300/350/F are placed in the luggage compartment of the vehicle at the assembly plant. For states that require a front license plate, install the bracket and bolts on the bumper cover during Pre-Delivery Service (PDS) according to the following procedure.

The RC 200t/300/350 (non-F Sport) models share the same installation procedure. The F Sport and F models require a different procedure (see page 4).

Warranty Information

OP CODE	DESCRIPTION	TIME	OFF	T1	T2
N/A	Not Applicable to Warranty	-	-	-	-

Front License Plate & Mounting Bracket Installation

Installation Procedure for RC 200t / 300 / 350 (non-F Sport)

1. Align holes "A" of the mounting bracket with the dimples on the front bumper cover.

HINT

- Holes "A" are used for installation of the front license plate mounting bracket to the bumper cover.
- Holes "B" are used for installation of the front license plate to the mounting bracket.

NOTICE

Do not drill into the dimples on the radiator grill.

Fig. 1

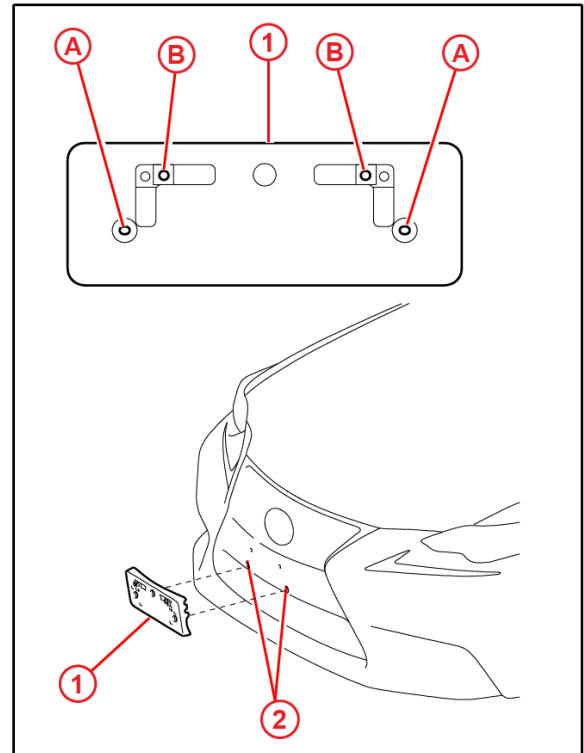

1	Mounting Bracket
2	Dimples

2. Install the mounting bracket to the front bumper cover at holes "A" using the 2 supplied self-tapping screws.

NOTICE

Do not over-tighten the self-tapping screws.

Fig. 2

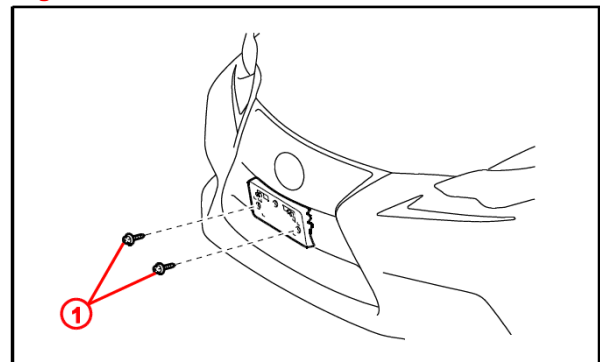

1	Self-tapping Screws
---	---------------------

Front License Plate & Mounting Bracket Installation

Installation Procedure for RC 200t / 300 / 350 (non-F Sport) (Continued)

3. Install the front license plate to the mounting bracket at holes "B" using two non-corroding bolts with the following dimensions:

Nominal Length: 10.0 mm (0.39 in.)

Diameter: 6.0 mm (0.24 in.)

Fig. 3

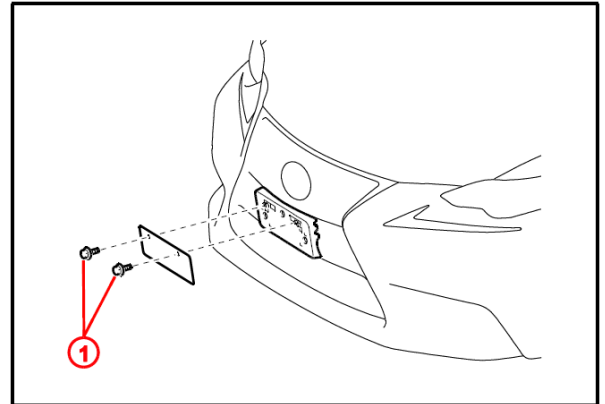

1	Bolts
----------	--------------

Fig. 4

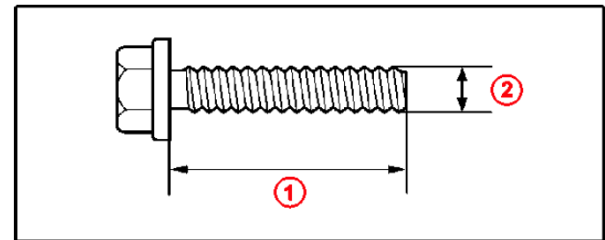

1	Nominal Length
2	Diameter

Front License Plate & Mounting Bracket Installation

Installation Procedure for F SPORT and RC F Models

1. Align holes "A" of the mounting bracket with the dimples (F Sport) or clips (RC F) on the radiator grill.

NOTICE
Do not drill into the dimples/clips on the radiator grill.

HINT

- Holes "A" are used for installation of the mounting bracket to the radiator grill.
- Holes "B" are used for installation of the front license plate to the mounting bracket.

Fig. 5

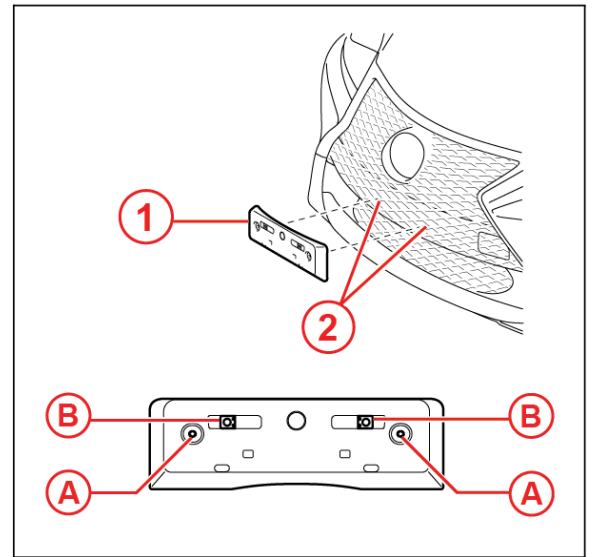

1	Mounting Bracket
2	Dimples (F Sport), Clips (RC F)

2. Install the mounting bracket to the radiator grill using 2 self-tapping screws.

NOTICE
Do not over-tighten the self-tapping screws.

3. Install the front license plate to the mounting bracket using the 2 non-corroding bolts with the following dimensions:

Fig. 6

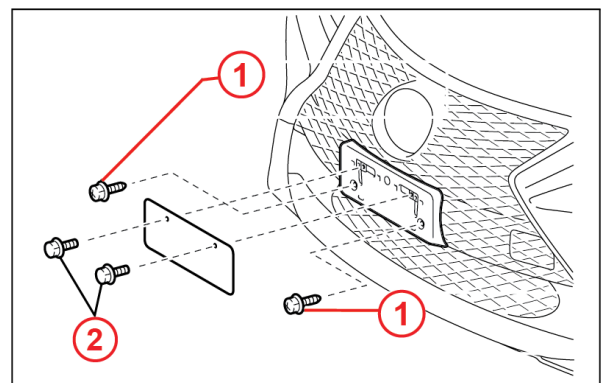

1	Self-tapping screws
2	Bolts

Front License Plate & Mounting Bracket Installation

Installation Procedure for F SPORT and RC F Models (Continued)

Nominal Length: 10.0 mm (0.39 in.)

Diameter: 6.0 mm (0.24 in.)

Fig. 7

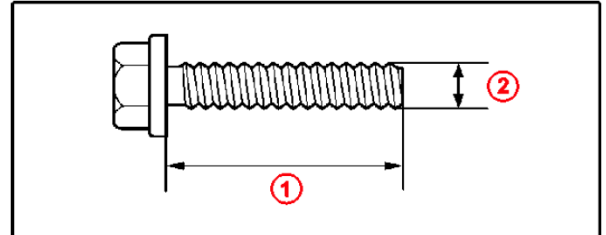

1	Nominal Length
2	Diameter