

Retail Operator / General Manager	Sales – Motorcycles	Sales – Used Motorcycles	Business Manager (F&I)	Service	Parts & Accessories	Administration
Date: March, 2015	Source: BMW Motorrad USA			Revised June 2016		
Bulletin #: 21 001 16 (005)R	Name: Gordon McDonnell Title: Manager – Service and Technical					



# BMW Motorrad USA

## Service Information Bulletin

### \*\*Technical Campaign\*\*

**Subject: Clutch slave cylinder**

**Models:** R 1200 GS (K50, 0A01/0A11)  
R 1200 GS Adventure (K51, 0A02/0A12)  
R 1200 RT (K52, 0A03/0A13)  
R 1200 R (K53, 0A04/0A14)  
R 1200 RS (K54, 0A05/0A15)

**Details:** BMW Motorrad has determined in the course of quality observation that in a few cases clutch fluid may leak between the clutch slave cylinder and the braided stainless steel clutch line. The cause is a burr in the clutch slave cylinder which may damage the gasket of the clutch line. A vehicle with high mileage can show signs of gradual impairment of the clutch function. The separating action of the clutch can worsen gradually over a period of time.

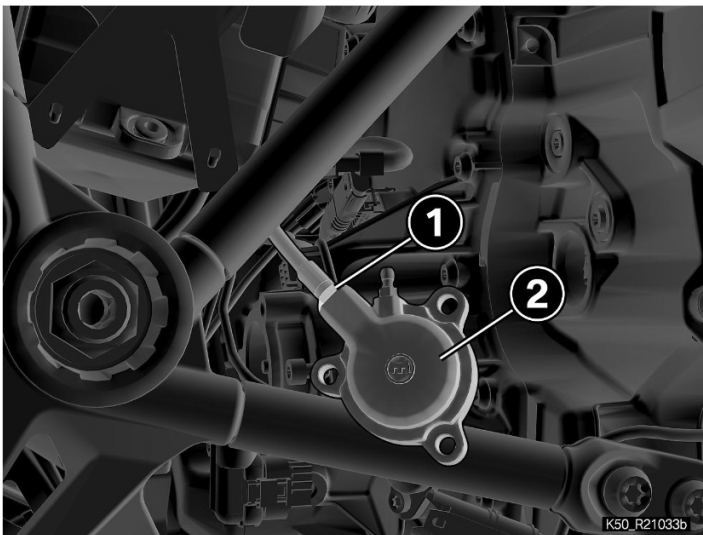

Illustration: Clutch slave cylinder

- Union screw (1)
- Clutch slave cylinder (2)

**Vehicles affected:** In order to determine if a specific vehicle is affected by this Technical Campaign, it will be necessary to verify all vehicle VINs through a DCS Vehicle History Check. Based on the response of the system, either proceed with the repair or take no further action. Please note, affected VINs may not appear until 24-72 hours after the release of this bulletin

**Production Solution:** A clutch slave cylinder with correct chamfer for the gasket of the braided stainless steel clutch line has been installed in production since 10/17/2015.

**Service Solution:** Before delivery or as part of the next workshop visit for the motorcycles affected, a new clutch slave cylinder is to be installed and the O-ring of the braided stainless steel clutch line is to be renewed.

## Warranty processing

Defect code	Description
00 21 04 00 00	Replacing clutch slave cylinder
FRU number	Description
00 60 269*	Replacing and bleeding clutch slave cylinder, <b>Refer to RSD for FRU amount of relevant model</b>
	K50, K51, K52, K53, K54
Part numbers	Description
21 52 8 525 828	1x Clutch slave cylinder
11 31 7 711 269	1x O-ring
12 41 1 459 445	1x Set, O-ring, starter motor

\*Main 00 60 269\*- this main labor operation crediting appropriate FRUs includes all repair procedures to complete the task with allowance for necessary ancillary tasks (e.g. visual inspection, lubrication, cleaning parts etc.) and administrative tasks.

Only one main labor operation can be claimed per repair visit. All other labor operations for any other line(s) must be claimed using plus code labor operations.

Please refer to the Warranty Policy and Procedures Manual regarding add-ons, proper support, documentation, claims submission and archiving requirements as applicable.

## Contact Information:

For technical inquires in relation to this bulletin	Please open a PuMA case
For warranty inquires in relation to this bulletin	Motorrad.Warranties@bmwna.com
For parts inquires in relation to this bulletin	Adam.Sacher@bmwnaext.com
Motorcycle Service and Technical Manager	Gordon.McDonnell@bmwna.com