

Front License Plate & Mounting Bracket Installation

Service Category General

Section Pre-Delivery Service

Market USA

Lexus Supports
ASE Certification 

Applicability

YEAR(S)	MODEL(S)	ADDITIONAL INFORMATION
2017	LS460	

Introduction

The front license plate mounting bracket and 2 self-tapping screws for the 2017 model year LS 460 are placed in the luggage compartment of the vehicle at the assembly plant. For states that require a front license plate, install the bracket during Pre-Delivery Service (PDS) according to the following procedure.

Warranty Information

OP CODE	DESCRIPTION	TIME	OFP	T1	T2
N/A	Not Applicable to Warranty	–	–	–	–

Front License Plate & Mounting Bracket Installation

Installation Procedure

1. Align holes "A" of the mounting bracket with the LOWER set of dimples on the front bumper cover.

NOTE

- There are 2 sets of dimples on the front bumper cover. Use the LOWER set of dimples.
- Holes "A" are used to install the mounting bracket to the bumper cover.
- Holes "B" are used for installation of the front license plate to the mounting bracket.

Figure 1.

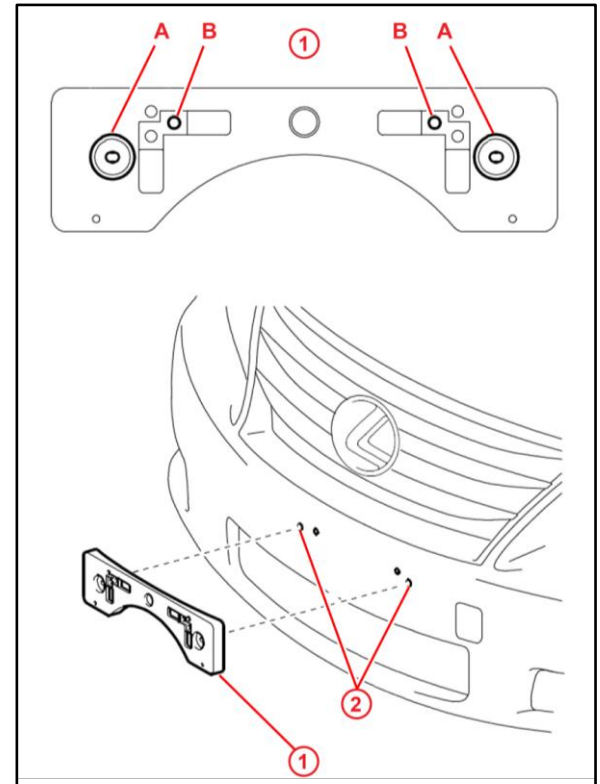

1	Mounting Bracket
2	Lower Dimples

2. Install the mounting bracket to the front bumper cover at holes "A" using the supplied self-tapping screws.

Front License Plate & Mounting Bracket Installation

Installation Procedure (Continued)

3. Install the front license plate to the mounting bracket at holes "B" using 2 non-corroding bolts with the following dimensions:

Nominal Length: 10.0 mm (0.39 in.)

Diameter: 6.0 mm (0.24 in.)

Figure 2.

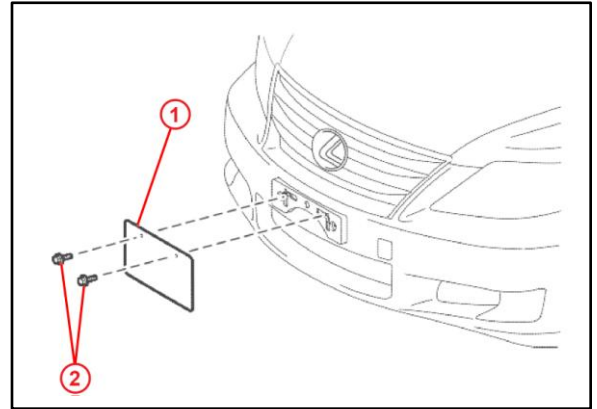

1	Front License Plate
2	Bolts

Figure 3.

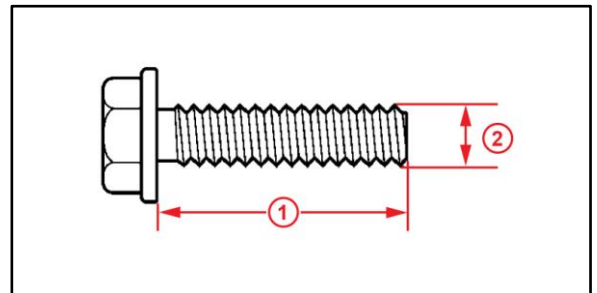

1	Nominal Length
2	Diameter