



ENGINE MECHANICAL WATER (COOLANT) PUMP: LIMITED WARRANTY EXTENSION TO 7 YEARS/84,000 MILES

MODEL

| | | | |
|---|---|---|---|
| R55 (Cooper Clubman) (N12 Engine) Model Years 2008 to 2010 produced from 12/1/2007 to 8/19/2010 | R55 (Cooper Clubman) (N16 Engine) Model Years 2011 to 2013 produced from 8/9/2010 to 11/15/2012 | R55 (Cooper S Clubman) (N14 Engine) Model Years 2008 to 2010 produced from 7/28/2007 to 9/13/2010 | R55 (Cooper S Clubman) (N18 Engine) Model Years 2011 to 2013 produced from 8/9/2010 to 11/15/2012 |
| R55 (Cooper S JCW Clubman) (N18 Engine) Model Year 2013 produced 9/10/2012 to 11/15/2012 | R56 (Cooper Hardtop) (N12 Engine) Model Years 2007 to 2010 produced from 12/2/2006 to 8/12/2010 | R56 (Cooper Hardtop) (N16 Engine) Model Years 2011 to 2013 produced from 7/31/2010 to 11/15/2012 | R56 (Cooper S Hardtop) (N14 Engine) Model Years 2007 to 2010 produced from 12/18/2006 to 9/8/2010 |
| R56 (Cooper S Hardtop) (N18 Engine) Model Years 2011 to 2013 produced from 8/9/2010 to 11/15/2012 | R56 (Cooper S JCW Hardtop) (N14 Engine) Model Years 2009 to 2012 produced from 4/28/2008 to 7/9/2012 | R56 (Cooper S JCW Hardtop) (N18 Engine) Model Year 2013 produced from 9/3/2012 to 11/14/2012 | R57 (Cooper Convertible) (N12 Engine) Model Years 2009 and 2010 produced from 1/7/2009 to 7/23/2010 |
| R57 (Cooper Convertible) (N16 Engine) Model Years 2011 to 2013 produced from 8/9/2010 to 11/15/2012 | R57 (Cooper S Convertible) (N14 Engine) Model Years 2009 and 2010 produced from 1/7/2009 to 7/23/2010 | R57 (Cooper S Convertible) (N18 Engine) Model Years 2011 to 2013 produced from 8/9/2010 to 11/15/2012 | R57 (Cooper S JCW Convertible) (N14 Engine) Model Years 2009 to 2012 produced from 2/24/2009 to 6/29/2012 |
| R57 (Cooper S JCW Convertible) (N18 Engine) Model Year | R58 (Cooper Coupe) (N16 Engine) Model Years 2012 and | R58 (Cooper S Coupe) (N18 Engine) Model Years 2012 and | R58 (Cooper S JCW Coupe) (N14 Engine) Model Year |

| | | | |
|--|--|--|---|
| 2013 produced from 7/9/2012 to 11/14/2012 | 2013 produced from 8/10/2011 to 11/15/2012 | 2013 produced from 8/10/2011 to 11/15/2012 | 2012 produced from 7/13/2011 to 7/12/2012 |
| R58 (Cooper S JCW Coupe) (N18 Engine) Model Year 2013 produced from 9/6/2012 to 11/15/2012 | R59 (Cooper Roadster) (N16 Engine) Model Years 2012 and 2013 produced from 10/3/2011 to 11/15/2012 | R59 (Cooper S Roadster) (N18 Engine) Model Years 2012 and 2013 produced from 8/17/2011 to 11/15/2012 | R59 (Cooper S JCW Roadster) (N18 Engine) Model Year 2013 produced from 9/4/2012 to 11/15/2012 |
| R60 (Cooper Countryman) (N16 Engine) Model Years 2011 to 2013 produced 11/2/2010 to 11/15/2012 | R60 (Cooper S Countryman) (N18 Engine) Model Years 2011 to 2013 produced 11/2/2010 to 11/15/2012 | R60 (Cooper S ALL4 Countryman) (N18 Engine) Model Years 2011 to 2013 produced 10/29/2010 to 11/15/2012 | |



Note: The model information above is for informational purposes only.

To determine a vehicle's eligibility for this coverage, always performing a VIN-specific DCSnet Warranty Inquiry first.

Please refer to the "Eligible Vehicles" section of this bulletin for further details.

INFORMATION

As part of a Class Action Suit Settlement for the vehicles listed above ("Class Vehicles"), MINI USA, a division of BMW of North America, LLC, is extending the limited warranty for the **engine mechanical water pump** to:

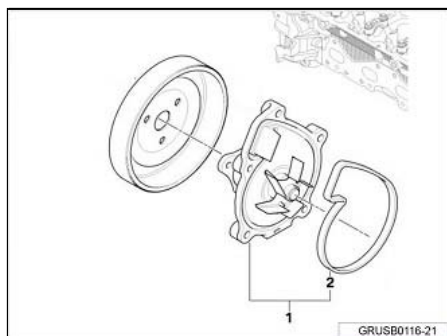

- Item #1: This "component-specific" limited warranty extension applies to defects in materials or workmanship.
- This coverage is subject to the same vehicle eligibility requirements, limitations, and exclusions that apply to the MINI New Passenger Car Limited Warranty.
- When it is necessary, the friction wheel is covered only when it is done in conjunction with performing an eligible and covered engine mechanical water pump repair.
- This extended coverage **does not** apply to

electric water pumps



Note: This bulletin is a notice of a component-specific “limited warranty extension

as part of a Class Action Settlement. This is NOT a notice of a Recall or Service Action.

There is no immediate repair required unless the MINI vehicle is currently experiencing a problem with the water pump.

ELIGIBLE VEHICLES

To assist you in identifying the “eligible vehicles” that have this extended limited warranty coverage, the DCSnet Warranty Vehicle Inquiry has been updated with the VIN-specific “Vehicle Comment” shown below:

MINI USA, a division of BMW NA, has extended the limited warranty for the engine mechanical water pump on this vehicle to 7 years/84,000 miles as determined from the original in-service date. This component-specific limited warranty extension applies to defects in materials or workmanship and is subject to the same vehicle eligibility requirements, limitations, and exclusions that apply to the MINI New Passenger Car Limited Warranty. See SI M01 12 16 (DC 11 51 90 01 00).



Note: Before performing and submitting a repair under this extended limited warranty,

always do a DCSnet Warranty inquiry first to confirm that the vehicle has the above “Notice of Limited Warranty Extension” in the Vehicle Comment section.

The “model year” production start (SOP) and end date (EOP) for a specific “model variant” within a “Series” will vary, please do not use a vehicle’s production date as the sole deterrent for ELW coverage eligibility.

If you have ELW eligibility and/or coverage question, please send an email with the VIN(s) and your question to the appropriate regional “questions” e-mail address **prior** to performing any repairs.

PARTS INFORMATION



Note: Please refer to the Electronic Parts Catalog (ETK/EPC), using the customer’s VIN

to locate the applicable replacement part numbers.

- **Only order these parts in the quantities needed to address customers’ vehicles that have confirmed failures.**
- **“Only in conjunction with” parts:** ETK/EPC may also identify additional part(s) that must be replaced or installed with the replacement of “Covered Parts”. These additional “required” items are also covered “in-conjunction” and under the terms of this extended limited

warranty.

- Also refer to ETK/EPC and the repair instructions for onetime-use fasteners/screws and other information regarding repair-related gaskets, seals, fluid and/or lubricants that also need to be replaced/used and claimed.

And:

Bulk Materials

| Part Number | Description | Quantity |
|-----------------|---------------------------------|-----------|
| 82 14 0 031 133 | Antifreeze/Coolant (One gallon) | As needed |

WARRANTY INFORMATION

The engine mechanical water pump limited warranty extension to 7 years/84,000 miles applies to “eligible US-specification MINI vehicles” that are registered, operated and have their covered repair performed by an authorized MINI dealer in the United States (including Puerto Rico).

This coverage supersedes the coverage that is provided under the MINI NEXT Certified Pre-Owned Limited Warranty or any BMW Group Vehicle Service Contract that applies to the vehicle.

Should the mechanical water pump fail again, this component is covered by the remaining portion of the extended limited warranty coverage period.

When it is necessary, the friction wheel is covered only when it is done in conjunction with performing an eligible and covered engine mechanical water pump repair

The existing limited warranty coverage for all other parts **has not** changed.

Non-Qualifying Repairs

Non-US specification vehicles, ineligible vehicles, eligible vehicles operated and repaired outside the United States and Puerto Rico and/or the diagnosis and repairs of other unrelated issues are not covered under the terms of this limited warranty extension.

Qualifying Repairs – Claim Submission

Claim this work with the defect code and labor operations that apply below.

| | | |
|---------------------|-------------------|--|
| Defect Code: | 1151900100 | MINI Mechanical Water (Coolant) Pump Limited Warranty Extension |
|---------------------|-------------------|--|



Note: Only one “Main” labor operation can be claimed per repair visit (one or more claims if applicable).

All other labor operations, either for the same repair line item or for other repair lines items, must

be claimed using Plus code (Associated when applicable) labor operations.

Applying this guideline, select and use the applicable flat rate labor operation(s) from the listing below.

| Labor Operation: | Labor Allowance: | Description: |
|-------------------------|-------------------------|---|
| 11 51 000 | Refer to KSD2 | Removing/installing/replacing coolant pump (Main work) |
| Or: | | |
| 11 51 508 | Refer to KSD2 | Removing/installing/replacing coolant pump (Plus work) |
| Or: | | |
| 11 51 504 | Refer to KSD2 | Removing/installing/replacing coolant pump (Associated work, coolant already drain in conjunction with performing another repair) |

And, as necessary

Additional Repair/Work Procedures

| Labor Operation: | Labor Allowance: | Description: |
|-------------------------|-------------------------|--|
| 17 00 009 | Refer to KSD2 | Check the cooling system for leaks (Main work) |
| Or: | | |
| 17 00 509 | Refer to KSD2 | Check the cooling system for leaks (Plus work) |
| Or: | | |
| 11 99 000 | Work time (WT) | Work time for localizing engine noise (mechanical water pump-related only) |

Refer to KSD2 for the corresponding flat rate unit (FRU) allowance.

Work time labor operation code 11 99 000 is not considered a Main labor operation; however, it does require an individual punch time and an explanation on the repair order and in the claim comments section.

And:

Bulk Materials

| | | |
|---------------|--|---|
| Sublet Code 4 | See sublet reimbursement calculation below | Reimbursement for replacing the drained quantity of antifreeze/coolant (Bulk container reference P/N 82 14 0 031 133, one gallon container. Do not use this part number for claim submission) |
|---------------|--|---|

Sublet calculation: MINI antifreeze/coolant (Bulk container reference P/N 82 14 0 031 133) - replacing the drained quantity (50/50 mixture) at dealer net plus your dealer's handling.

Enter this material cost in sublet and itemize the amount on the repair order in the claim comment section.

Prior Customer-Pay Water Pump Repairs/Replacements

Please visit the following website for the reimbursement eligibility and procedure information:

<https://waterpumpsettlement.com/>

[Copyright ©2016 BMW of North America, Inc.]