

NUMBER: 00.01.16.0011.03

DATE: July 2016

MODEL: MY12 Fisker KARMA and MY17 Karma REVERO

TITLE: Traction Motor and Inverter Location and Nomenclature

APPLICABILITY: All

MARKET REGIONS: ALL

PURPOSE: This Service Tip is to clearly define locations and a consistent name assignment for Traction Motor 1 (TM1), Traction Motor 2 (TM2), and the Power Inverter Modules (PIM's 1 and 2) for the Fisker Karma and the Karma Revero.

This document supersedes any and all previous documents relating to the traction motors and the inverters' names and locations in workshop manuals, wiring diagrams, training documents, parts catalog, labor ops, etc.

Component Name	Also Known As
Traction Motor 1	Traction Motor A, Drive Motor A, TM1, TM'A'
Traction Motor 2	Traction Motor B, Drive Motor B, TM2, TM'B'
Inverter 1	Power Inverter Module 1, PIM 1, PIM A, Power Inverter Module A
Inverter 2	Power Inverter Module 2, PIM 2, PIM B, Power Inverter Module B

NOTE: Traction Motor 1, is the *Rear* most mounted motor.
 The corresponding Power Inverter Module (PIM) - *Inverter 1* is on the *driver side*.
 Traction motor 2 is the *fore* mounted motor with the respective *Inverter 2* on the *passenger side*.

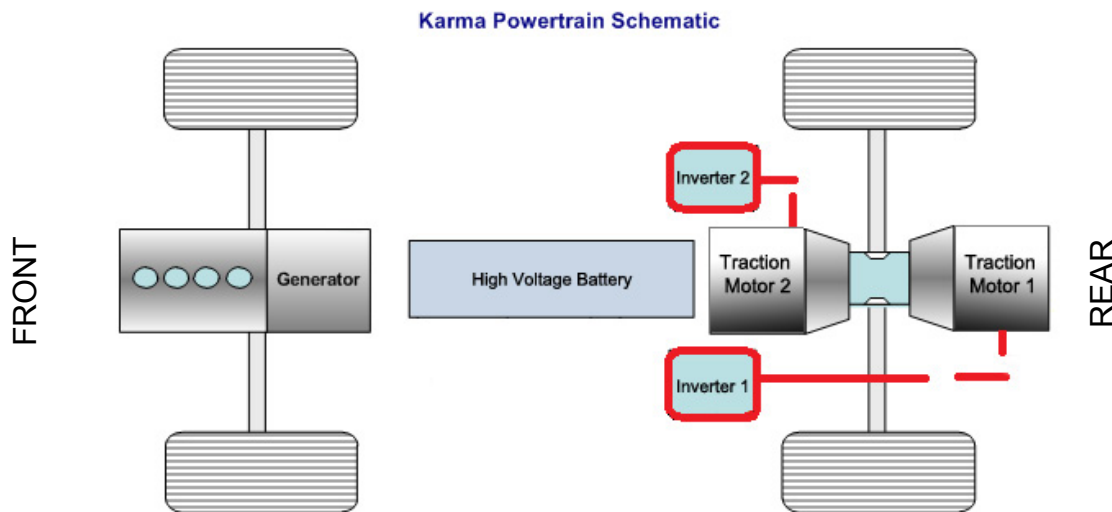

Karma Automotive Bulletins and service documents are intended for use by experienced and trained Technicians. If you lack the skills, tools, equipment and a suitable workshop for any procedure described in this document, we suggest you leave such repairs to an Authorized Karma Service Provider or qualified service center. See your service provider for advice on whether your vehicle may benefit from the information contained within this document. The information contained in the Karma Bulletin is accurate at the date of publication. However, Karma Automotive regularly updates technical information. Please check with your Karma Automotive Service Provider that the bulletin you intend to use contains the latest available information.