

MIL "ON" DTC P0A94, P324E, P0A1A, and/or P3004

Service Category Engine/Hybrid System

Section Hybrid/Battery Control System

Market USA

Toyota Supports
 ASE Certification 

Applicability

YEAR(S)	MODEL(S)	ADDITIONAL INFORMATION
2012 - 2014	Prius V	
2010 - 2014	Prius	

Introduction

Some 2010 – 2014 Prius and 2012 – 2014 Prius V model vehicles may exhibit a MIL “ON” condition with DTCs P0A94, P324E, P0A1A, or P3004, indicating a malfunction has occurred in the hybrid inverter assembly. To help identify the specific components within the inverter assembly that need to be replaced, follow the steps in this service bulletin to address the condition.

Warranty Information

OP CODE	DESCRIPTION	TIME	OFF	T1	T2
EL1602	R & R the Inverter Assembly with Converter	2.0	G9200-#####	8A	73
EL1603	R & R the IPM Transistor	2.9			
EL1604	R & R the IPM Transistor and the MG ECU	2.9			

APPLICABLE WARRANTY

- This repair is covered under the Toyota Hybrid System Warranty. This warranty is in effect for 96 months or 100,000 miles, whichever occurs first, from the vehicle's in-service date.
- Warranty application is limited to occurrence of the specified condition described in this bulletin.

MIL "ON" DTC P0A94, P324E, P0A1A, and/or P3004

Parts Information

NOTE
Not all parts listed are needed for HV inverter repair, this list is for reference only. Refer to the tables below for appropriate components based on the condition BEFORE ordering parts.

PART NUMBER*	PART NAME	QTY
G920H-47030	Computer Sub-Assy, MG Control w/Bracket	1
G920H-47040		
G920J-52010	Sensor Sub-Assy, Inverter Current	
G9208-47090	Wire Sub-Assy, Inverter	
04899-47021	Transistor Kit, Power Module Intelligent (IPM)	
04899-47060	Plug Kit, Inverter Drain	
90430-18008	Gasket	
G922L-47010	Cover, Inverter Signal Connector	1 (Parts not required, available in case of breakage.)
91551-80618	Bolt, Flange	
091X1-47020	Seal, Masking, No. 1	1 (Part included in IPM Kit, available in case spare is needed.)
08887-02809	Toyota Thermal Grease X-23-7884-4	2 (Used only for IPM replacement. Product has shelf life of 1 year, do NOT use if stored past 1 year)
08826-00100	Seal Packing (or equivalent)	1
00272-SLLC2	Super Long Life Coolant	

* Part numbers are subject to change.

MIL "ON" DTC P0A94, P324E, P0A1A, and/or P3004

Required Tools & Equipment

REQUIRED EQUIPMENT	SUPPLIER	PART NUMBER	QTY
Techstream 2.0*	ADE	TS2UNIT	1
Techstream Lite		TSLITEPDLR01	
Techstream Lite (Green Cable)		TSLP2DLR01	

NOTE

- Only ONE of the Techstream units listed above is required.
- Software version 11.10.034 or later is required.
- Additional Techstream units may be ordered by calling Approved Dealer Equipment (ADE) at 1-800-368-6787.

SPECIAL SERVICE TOOLS (SST)	PART NUMBER	QTY
Electrical Insulating Gloves*	00002-03100-S (Small)	1
	00002-03200-M (Medium)	
	00002-03300-L (Large)	

CAUTION

Always inspect Electrical Insulating Gloves before use for cracks, ruptures, tears, pinholes, or damage. Do NOT wear if damaged.

NOTE

Additional SSTs may be ordered by calling 1-800-933-8335.

SPECIAL SERVICE TOOLS (SST)	PART NUMBER	QTY
Oil Seal Puller*	09308-00010	1
Anti-Static Mat*	09890-47010	1
Squeegee*	09891-47010	1
Torque Wrench Adapter*	09961-00950	1
Inverter Case Separator*	09891-47020	1

* Essential SST.

MIL "ON" DTC P0A94, P324E, P0A1A, and/or P3004

Repair Procedure for 2010 – 2014 Prius Vehicles

Figure 1.

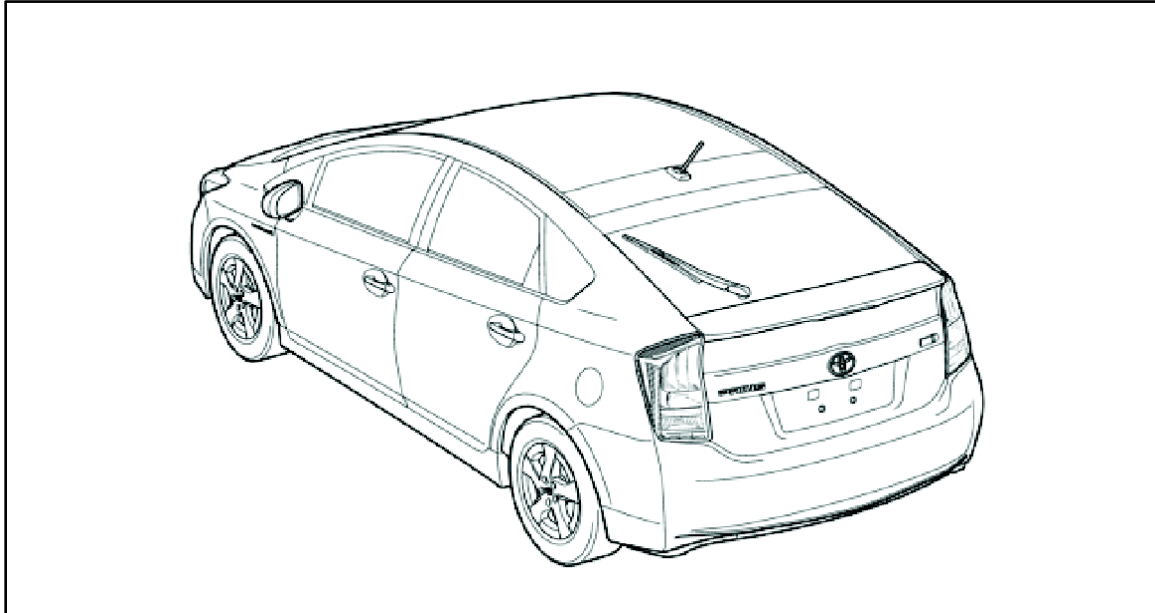

1. Confirm DTCs are present.
2. If multiple DTCs are present, save the freeze frame data.
3. After saving the freeze frame data, clear codes and confirm what DTCs reset.
4. If multiple codes return, follow the repair manual diagnosis procedure for the DTC with Freeze Frame Data Occurrence Order value of "1".
5. Check the position of the Part Number label on the inverter.
 - Type A Inverters:
Label is on side surface for all part numbers.
Label is on upper surface for part numbers: G9200-47140, G9200-47141, G9200-47180 and G9200-47181 only.
 - Type B Inverters:
Label is on upper surface.
6. Determine the repair components based on inverter type and DTC detail code.

Figure 2.

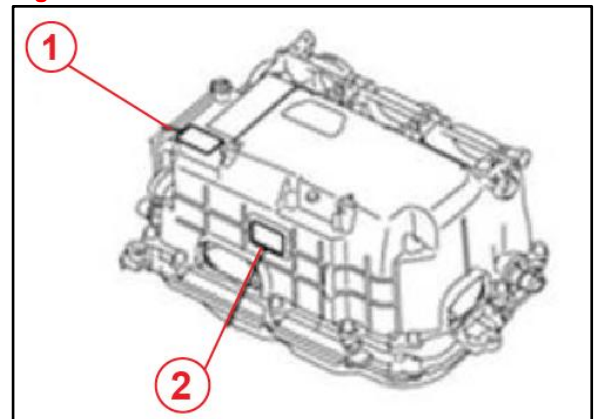

1	Upper surface
2	Side surface

MIL "ON" DTC P0A94, P324E, P0A1A, and/or P3004

Repair Procedure for 2010 – 2014 Prius Vehicles (Continued)

Use the correct table below to identify the parts required for repair. The correct parts are listed in the bottom row of the table.

Prius Inverter Type A: Required Parts by DTC

DTC	DTC DETAIL CODE	IPM REPLACEMENT	<ul style="list-style-type: none"> • MG-ECU • CURRENT SENSOR • INVERTER WIRE HARNESS 	<ul style="list-style-type: none"> • MG-ECU • CURRENT SENSOR • IPM • INVERTER WIRE HARNESS 	INVERTER ASSEMBLY
P0A94	127			X	
	172	X			
	442			X	
	547		X		
	548			X	
	549		X		
	550			X	
	553	X			
	554		X		
	555			X	
	556		X		
	557	X			
	564			X	
	585			X	
	587			X	
	589			X	
590			X		

MIL "ON" DTC P0A94, P324E, P0A1A, and/or P3004

Repair Procedure for 2010 – 2014 Prius Vehicles (Continued)

Prius Inverter Type A: Required Parts by DTC (Continued)

DTC	DTC DETAIL CODE	IPM REPLACEMENT	<ul style="list-style-type: none"> • MG-ECU • CURRENT SENSOR • INVERTER WIRE HARNESS 	<ul style="list-style-type: none"> • MG-ECU • CURRENT SENSOR • IPM • INVERTER WIRE HARNESS 	INVERTER ASSEMBLY
P324E	788			X	
P0A1A	151			X	
	155		X		
	156		X		
	166		X		
	200		X		
	658		X		
	659		X		
	791		X		
P3004	131				X
	132				X
	800	X			
	801	X			
PARTS & QUANTITY (QTY) FOR SPECIFIC DTC REPAIR		04899-47021 QTY 1 08887-02809 QTY 2 04899-47060 QTY 1	G920J-52010 QTY 1 G920H-47030 QTY 1 G9208-47090 QTY 1	G920H-47030 QTY 1 G920J-52010 QTY 1 04899-47021 QTY 1	G9200-49056 QTY 1 00272-SLLC2 QTY 1

MIL "ON" DTC P0A94, P324E, P0A1A, and/or P3004

Repair Procedure for 2010 – 2014 Prius Vehicles (Continued)

Prius Inverter Type B: Required Parts by DTC

DTC	DTC DETAIL CODE	IPM REPLACEMENT	MG-ECU	<ul style="list-style-type: none"> • MG-ECU • IPM 	<ul style="list-style-type: none"> • MG-ECU • CURRENT SENSOR • IPM 	INVERTER ASSEMBLY
P0A94	127			X		
	172	X				
	442			X		
	547		X			
	548				X	
	549		X			
	550				X	
	553	X				
	554			X		
	555					X
	556			X		
	557	X				
	564				X	
	585				X	
	587				X	
	589				X	
590				X		
P324E	788				X	
P0A1A	151				X	
	155		X			
	156		X			
	166		X			
	200		X			
	658		X			
	659		X			
	791		X			
	792		X			
	793		X			

MIL "ON" DTC P0A94, P324E, P0A1A, and/or P3004

Repair Procedure for 2010 – 2014 Prius Vehicles (Continued)

Prius Inverter Type B: Required Parts by DTC (Continued)

DTC	DTC DETAIL CODE	IPM REPLACEMENT	MG-ECU	• MG-ECU • IPM	• MG-ECU • CURRENT SENSOR • IPM	INVERTER ASSEMBLY
P3004	131					X
	132					X
	800	X				
	801	X				
PARTS & QUANTITY (QTY) FOR SPECIFIC DTC REPAIR		04899-47021 QTY 1 08887-02809 QTY 2 04899-47060 QTY 1 08826-00100 QTY 1 90430-18008 QTY 1 00272-SLLC2 QTY 1	G920H-47030 QTY 1 04899-47060 QTY 1 08826-00100 QTY 1 90430-18008 QTY 1 00272-SLLC2 QTY 1	04899-47021 QTY 1 08887-02809 QTY 2 G920H-47030 QTY 1 04899-47060 QTY 1 08826-00100 QTY 1 90430-18008 QTY 1 00272-SLLC2 QTY 1	04899-47021 QTY 1 08887-02809 QTY 2 G920H-47030 QTY 1 G920J-52010 QTY 1 04899-47060 QTY 1 08826-00100 QTY 1 90430-18008 QTY 1 00272-SLLC2 QTY	*G9200-49025 (FOR PRODUCTION DATES OF 04/2009-10/2013) QTY 1 *00272-49075 (FOR PRODUCTION DATES AFTER 10/2013) QTY 1 00272-SLLC2 QTY 1

Repair Procedure for 2012 – 2014 Prius V Vehicles

Figure 3.

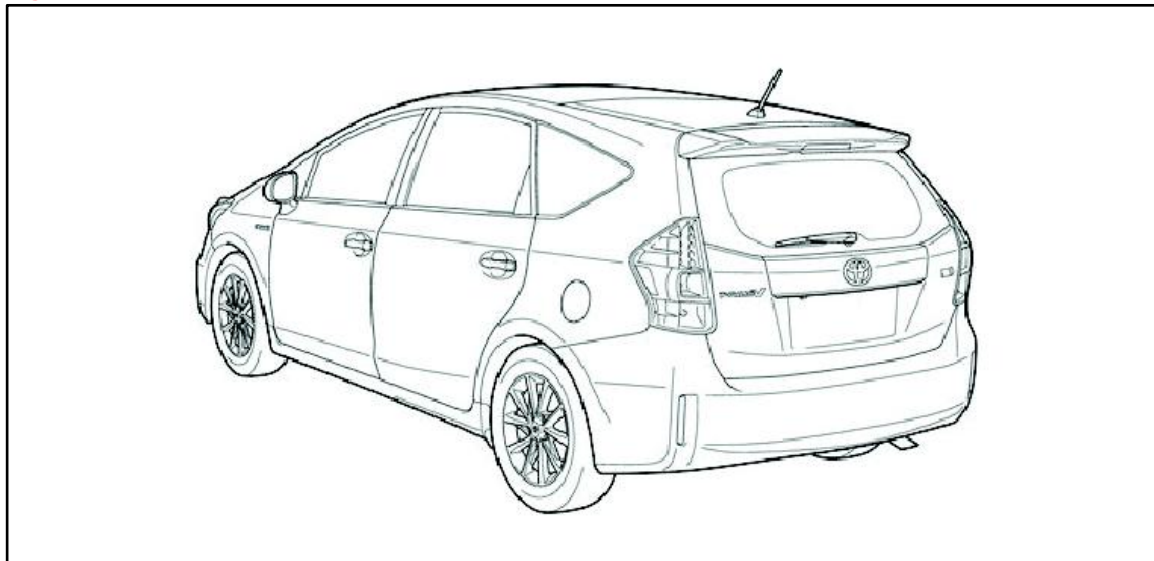

1. Confirm DTCs are present.
2. If multiple DTCs are present save the freeze frame data.

MIL "ON" DTC P0A94, P324E, P0A1A, and/or P3004

Repair Procedure for 2012 – 2014 Prius V Vehicles (Continued)

3. After saving the freeze frame data, clear codes and confirm what DTCs reset.
4. If multiple codes return follow the Repair Manual diagnosis procedure for the DTC with Freeze Frame Data Occurrence Order value of "1".
5. Check the position of the Part Number label on the inverter.
6. Type A Inverters:
 - Label is on side surface for all part numbers.
 - Label is on upper surface for part numbers: G9200-47160, G9200-47161, G9200-47162 ONLY.
7. Type B Inverters:
 - Label is on upper surface.
8. Determine repair components based on inverter type and DTC detail code.

Figure 4.

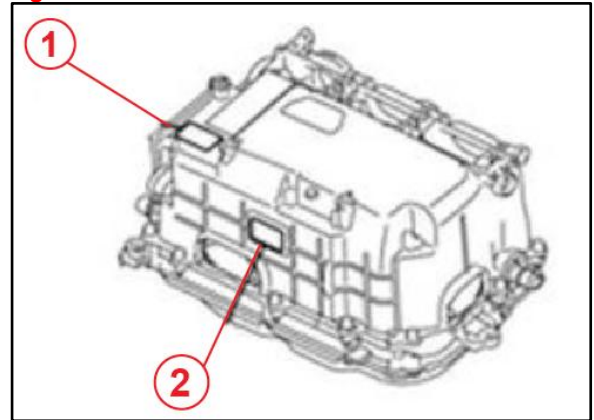

1	Upper surface
2	Side surface

Use the correct table below to identify the parts required for repair, the correct parts are listed in the bottom row of the table.

Prius V Inverter Type A: Required Parts by DTC

DTC	DTC DETAIL CODE	IPM REPLACEMENT	<ul style="list-style-type: none"> • MG-ECU • CURRENT SENSOR • IPM • INVERTER WIRE HARNESS 	INVERTER ASSEMBLY
P0A94	127		X	
	172	X		
	442		X	
	548		X	
	550		X	
	553	X		
	555		X	
	557	X		
	564		X	
	585		X	
	587		X	
	589		X	
	590		X	

MIL "ON" DTC P0A94, P324E, P0A1A, and/or P3004

Repair Procedure for 2012 – 2014 Prius V Vehicles (Continued)

Prius V Inverter Type A: Required Parts by DTC (Continued)

P324E	788		X	
P0A1A	151		X	
P3004	131			X
	132			X
	800	X		
	801	X		
PARTS & QUANTITY (QTY) FOR SPECIFIC DTC REPAIR	04899-47021 QTY 1 08887-02809 QTY 2 04899-47060 QTY 1 08826-00100 QTY 1 90430-18008 QTY 1 00272-SLLC2 QTY 1		G920H-47040 QTY 1 G920J-52010 QTY 1 04899-47021 QTY 1 08887-02809 QTY 2 G9208-47090 QTY 1 04899-47060 QTY 1 08826-00100 QTY 1 90430-18008 QTY 1 00272-SLLC2 QTY 1	G9200-49056 QTY 1 00272-SLLC2 QTY 1

Prius V Inverter Type B: Required Parts by DTC

DTC	DTC DETAIL CODE	IPM REPLACEMENT	<ul style="list-style-type: none"> • MG-ECU • IPM 	<ul style="list-style-type: none"> • MG-ECU • CURRENT SENSOR • IPM 	INVERTER ASSEMBLY
P0A94	127		X		
	172	X			
	442		X		
	548			X	
	550		X		
	553	X			
	555				X
	557	X			
	564			X	
	585			X	
	587			X	
	589			X	
590			X		
P324E	788			X	
P0A1A	151			X	

MIL "ON" DTC P0A94, P324E, P0A1A, and/or P3004

Repair Procedure for 2012 – 2014 Prius V Vehicles (Continued)

Prius V Inverter Type B: Required Parts by DTC (Continued)

P3004	131				X
	132				X
	800	X			
	801	X			
PARTS & QUANTITY (QTY)		04899-47021 QTY 1 08887-02809 QTY 2 04899-47060 QTY 1 08826-00100 QTY 1	G920H-47040 QTY 1 04899-47021 QTY 1 08887-02809 QTY 2 04899-47060 QTY 1 08826-00100 QTY 1	G920H-47040 QTY 1 G920J-52010 QTY 1 04899-47021 QTY 1 08887-02809 QTY 2 04899-47060 QTY 1 08826-00100 QTY 1	G9200-49056 QTY 1 00272-SLLC2 QTY 1
FOR SPECIFIC DTC REPAIR		90430-18008 QTY 1 00272-SLLC2 QTY 1	90430-18008 QTY 1 00272-SLLC2 QTY 1	90430-18008 QTY 1 00272-SLLC2 QTY 1	

Repair Procedure 2010 – 2014 Prius and 2012 – 2014 Prius V Vehicles

- Repair the inverter. Refer to the Technical Information System (TIS), applicable model, and model year Repair Manual:
 - 2010 Prius:
Engine/Hybrid System – Hybrid/Battery Control – [“Hybrid/Battery Control: Power Module Intelligent Transistor: Removal / Installation”](#)
 - 2011 Prius:
Engine/Hybrid System – Hybrid/Battery Control – [“Hybrid/Battery Control: Power Module Intelligent Transistor: Removal / Installation”](#)
 - 2012 Prius:
Engine/Hybrid System – Hybrid/Battery Control – [“Hybrid/Battery Control: Power Module Intelligent Transistor: Removal / Installation”](#)
 - 2013 Prius:
Engine/Hybrid System – Hybrid/Battery Control – [“Hybrid/Battery Control: Power Module Intelligent Transistor: Removal / Installation”](#)
 - 2014 Prius:
Engine/Hybrid System – Hybrid/Battery Control – [“Hybrid/Battery Control: Power Module Intelligent Transistor: Removal / Installation”](#)
 - 2012 Prius V:
Engine/Hybrid System – Hybrid/Battery Control – [“Hybrid/Battery Control: Power Module Intelligent Transistor: Removal / Installation”](#)

MIL "ON" DTC P0A94, P324E, P0A1A, and/or P3004

Repair Procedure for 2010 – 2014 Prius and 2012 – 2014 Prius V Vehicles (Continued)

- 2013 Prius V:
Engine/Hybrid System – Hybrid/Battery Control – [“Hybrid/Battery Control: Power Module Intelligent Transistor: Removal / Installation”](#)
- 2014 Prius V:
Engine/Hybrid System – Hybrid/Battery Control – [“Hybrid/Battery Control: Power Module Intelligent Transistor: Removal / Installation”](#)

2. Clear DTCs and confirm repair.

HINT

The link below contains best practices when repairing the inverter.

[Quick Training Guide – QTG014B: Prius Inverter Repair Best Practices](#)