

# WTD-65 Steering Column Recall - Updated Repair Procedure

**TO:** SDC EST CEN WST  
**FROM:** Subaru of America, Inc.  
**DEPARTMENT:** Service  
**DATE:** 05/17/2016  
**CATEGORY:** Show in all Categories

---

Repair procedure WTD-65R was updated today. [Click here to view WTD-65R](#) - which are also posted on STIS (Subaru Technical Information System).

**As an important reminder, always refer to STIS for the latest service information before performing any repairs.**

[Back to List](#)

---

**ATTENTION:**

- GENERAL MANAGER
- PARTS MANAGER
- CLAIMS PERSONNEL
- SERVICE MANAGER

IMPORTANT - All Service Personnel Should Read and Initial in the boxes provided, right.



QUALITY DRIVEN® SERVICE

© 2016 Subaru of America, Inc. All rights reserved.

## REPAIR PROCEDURE

**APPLICABILITY:** 2016-2017MY Legacy and Outback  
**SUBJECT:** Inspection and Repair Procedure for Stop Sale / Recall Campaign  
 WTD-65: Steering Column

**NUMBER:** WTD-65R  
**DATE:** 05/10/16  
**REVISED:** 05/17/16

**IMPORTANT:** For more information, refer to Subarunet messages dated 5/9, 5/10 (2), and 5/11 regarding the WTD-65 Stop Sale Notice. A complete Product Campaign Bulletin will be released shortly. This bulletin is to inform Subaru retailers of the inspection and repair procedures only.

This Service Procedure provides an inspection method for identification of affected vehicles and if determined necessary, additional steps for replacing the steering column assembly.

### INSPECTION PROCEDURE:

- Coverage for all affected vehicles must be confirmed by using the Vehicle Coverage Inquiry function on subarunet.com. This data is now available.

Models		Potentially Affected VIN Range (last 8 digits)
2016	Legacy	From G3045004 to G3059641
2016	Outback	From G3307507 to G3346346
2017	Legacy	From H3002001 to H3002024
2017	Outback	From H3200001 to H3200048

- Locate the lot number label at the base of the steering column located just above the toe board grommet as shown in the photo below.

**VERY IMPORTANT:**

For KEY START models, the label will have a large "02" as shown in the photo.  
 For PUSH START models, the label will have a large "03".

The steering columns are **NOT** interchangeable.



*Continued...*

<p><b>CAUTION: VEHICLE SERVICING PERFORMED BY UNTRAINED PERSONS COULD RESULT IN SERIOUS INJURY TO THOSE PERSONS OR TO OTHERS.</b></p> <p>Subaru Service Bulletins are intended for use by professional technicians ONLY. They are written to inform those technicians of conditions that may occur in some vehicles, or to provide information that could assist in the proper servicing of the vehicle. Properly trained technicians have the equipment, tools, safety instructions, and know-how to do the job correctly and safely. If a condition is described, DO NOT assume that this Service Bulletin applies to your vehicle, or that your vehicle will have that condition.</p>	<p><b>SUBARU OF AMERICA, INC. IS ISO 14001 COMPLIANT</b></p> <p>ISO 14001 is the international standard for excellence in Environmental Management Systems. Please recycle or dispose of automotive products in a manner that is friendly to our environment and in accordance with all local, state and federal laws and regulations.</p>
------------------------------------------------------------------------------------------------------------------------------------------------------------------------------------------------------------------------------------------------------------------------------------------------------------------------------------------------------------------------------------------------------------------------------------------------------------------------------------------------------------------------------------------------------------------------------------------------------------------------------------------------------------------------------------------	--------------------------------------------------------------------------------------------------------------------------------------------------------------------------------------------------------------------------------------------------------------------------------------------------------------------------------------------

- Decode the lot number of the steering column using the illustration below.
- **Affected steering columns will have a lot number label indicating the column was produced on or between 6228 (February 28, 2016) and 6416 (April 16, 2016), the steering column assembly must be replaced.**
- If the lot number is illegible or otherwise cannot be determined, it must be noted on the repair order and the steering column assembly must be replaced.

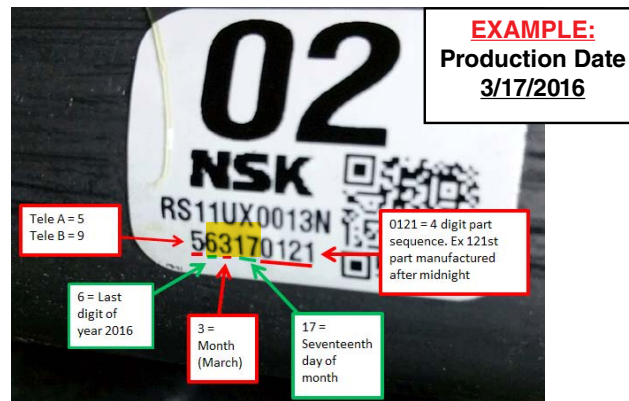

- **IMPORTANT:** Always record the original lot number on the Repair Order even if it is outside the affected range. **The ORIGINAL 4-digit lot number must also be entered in the Miscellaneous Detail field when submitting for claim reimbursement. If illegible, enter “ILLEGIBLE” in that field.**

**PARTS INFORMATION:**

Description	Part Number	Applicability	Quantity
COLUMN ASSEMBLY	34500AL02A	Key Start	1
	34500AL03A	Push-Button Start	1
<b>BOLT (shear)*</b>	<b>83140GA000</b>	<b>All</b>	<b>1</b>
<b>WTD65 STEERING COLUMN SHAFT GASKET KIT**</b>	<b>SOA635143</b>	<b>H-6 Models Only</b>	<b>1</b>

*\* One new shear bolt is included with the replacement steering column assembly.*

*\*\*The SOA635143 kit is comprised of: 2- 44011AG040 and 1- 44022AA123 exhaust gaskets.*

*The SOA635143 kit will be shipped in a separate package concurrent with the steering column shipment.*

**SERVICE PROCEDURE:**

After performing the Inspection procedure, if determined necessary, replace the steering column assembly following the Service Procedure provided below.

**CAUTION:** Refer to the “CAUTION” Section in the General Description portion of Airbag System AB in the Body Section of the applicable Service Manual before handling any airbag module!

- Before proceeding with disassembly, unlock the tilt lever (1), adjust the tilt position of the steering column to the neutral position (2), adjust the telescopic position to the longest position (3) and place the lock lever back into the “locked” position (4).

*Continued...*

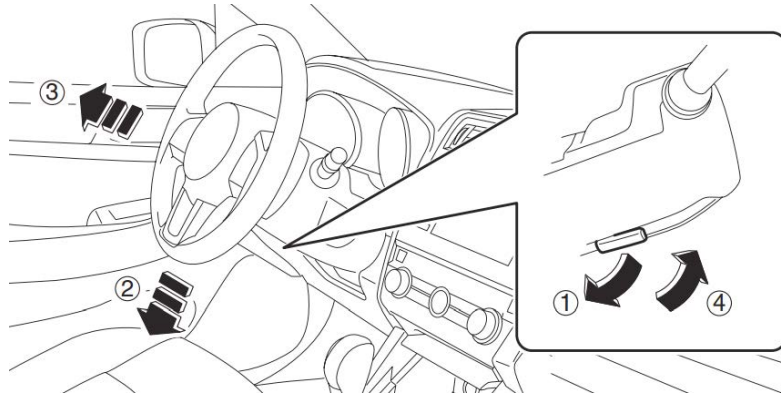

- Record the customer's radio station presets (and Navigation Favorites where applicable).
- Confirm the status of STARLINK Telematics lamp (where applicable). If the Green LED is on, press the RED SOS button to confirm an operator answers. **Inform the Operator this is only a test.**
- Disconnect the negative battery cable from the battery sensor and wait at least 60 seconds before proceeding.
- Using a plastic trim tool, remove the instrument panel end cover.

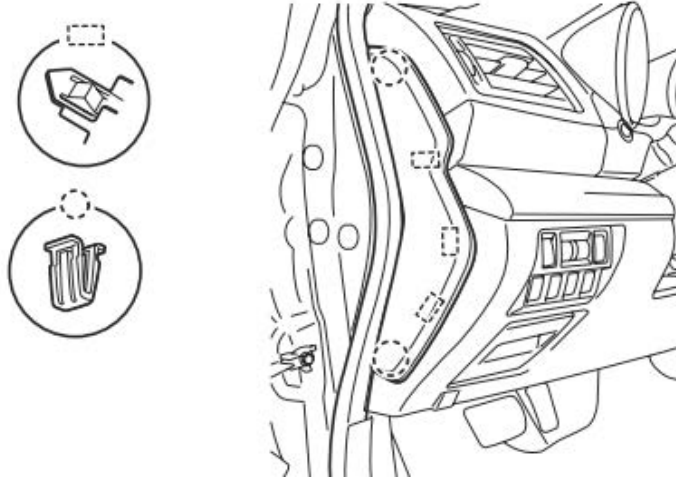

- Remove the data link connector, release the 3 retaining clips and remove the lower the instrument panel under cover.

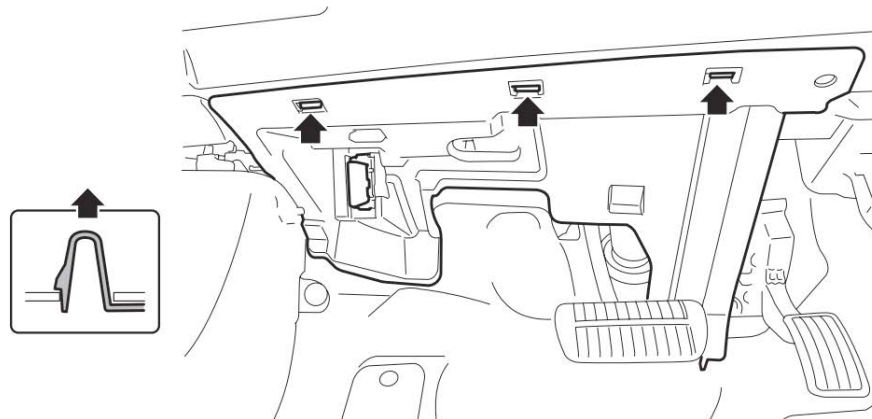

- Remove the necessary screws, release the claws and disconnect the harness connectors from the switches before **CAREFULLY** removing the instrument panel lower trim cover. **NOTE:** When removing the cover, pull it straight back toward you as shown in the illustration below. Do not pull / turn it upward as doing so may damage the retaining claws.

*Continued...*

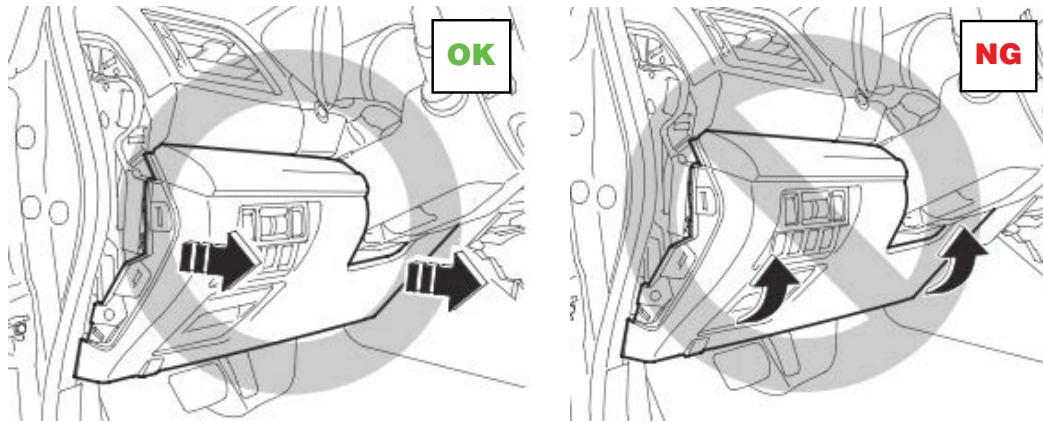

- Remove the knee guard.

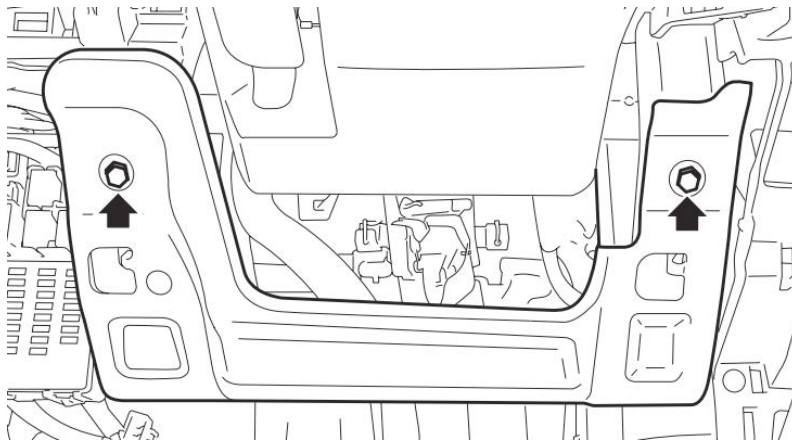

- With the wheels pointed straight ahead and using a hexagon wrench (or equivalent) wrapped with protective tape, locate and press on the snap pins to release the locks (three locations) securing the driver's airbag module.

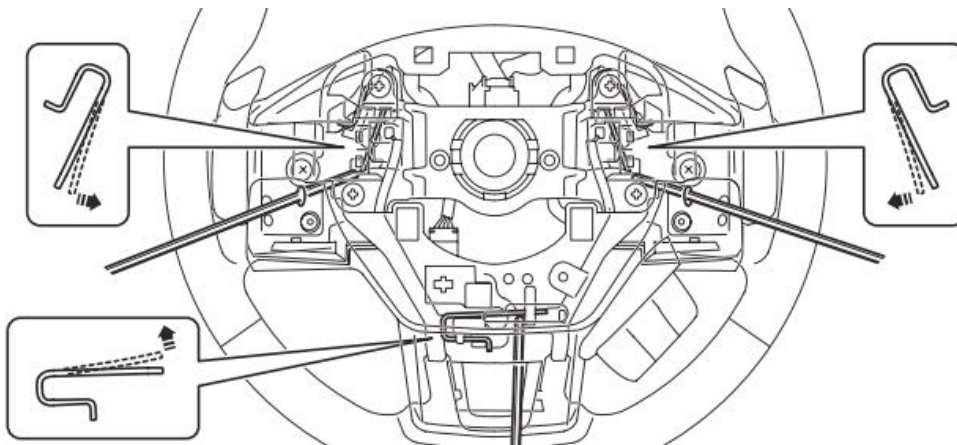

- **CAREFULLY**, release / remove the 2 airbag module harness connectors and set the module aside in a safe place.

*Continued...*

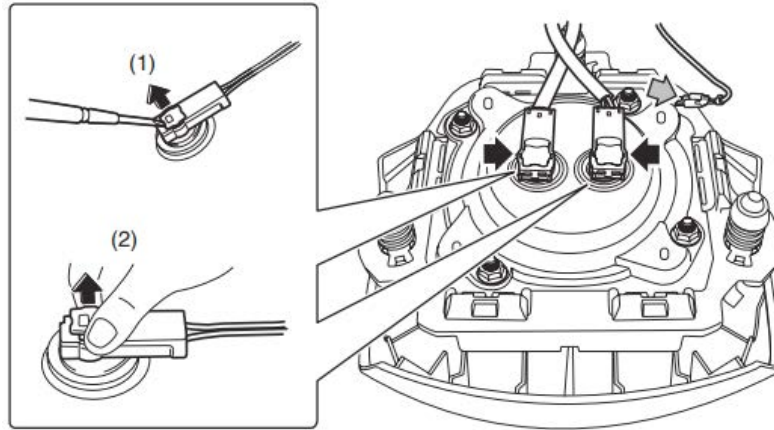

- Using a steering wheel puller to prevent deforming the steering wheel, remove the steering wheel.
- Using a plastic trim tool, **CAREFULLY** release the retaining claws and remove the upper and lower steering column trim covers.

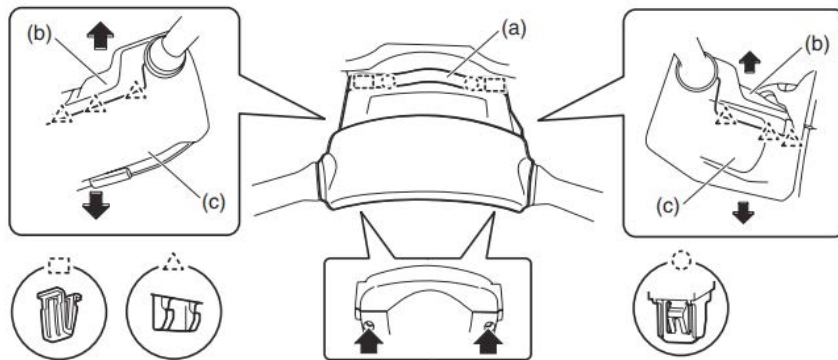

- After disconnecting all the wiring harness connectors, **CAREFULLY** remove the roll connector, steering angle sensor and the combination switch assemblies. **IMPORTANT:** Do not disturb the position of the roll connector while removed from the steering column. **As shown in the photo, use a piece of tape to keep it in alignment while removed.** **IF** the roll connector position is changed, the center position adjustment procedure provided below must be performed during reassembly.

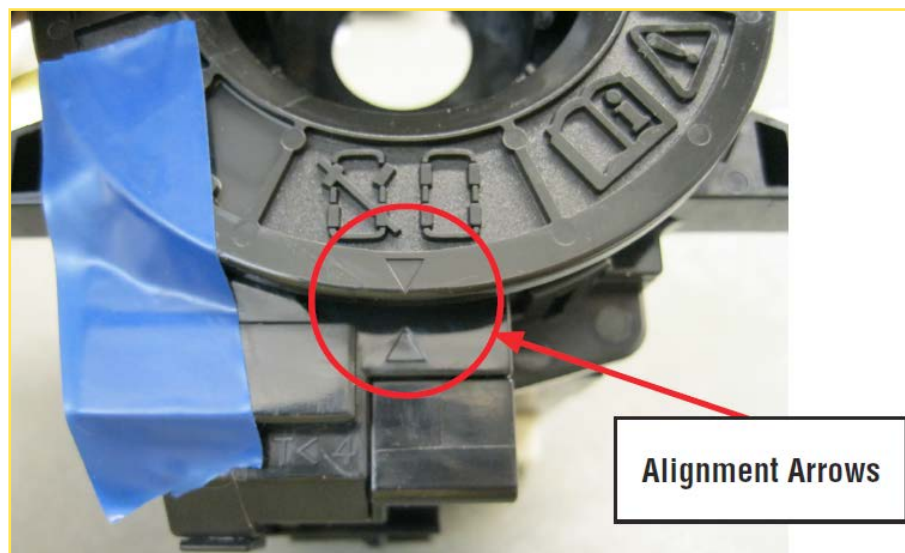

*Continued...*

**Center Position Adjustment Procedure (Use only if roll connector position changed):**

**CAUTION:** Do not rotate the roll connector to more than the specified number of turns. Otherwise, the roll connector internal wire may be broken. When determining the end stop, rotate the connector slowly without applying excessive force. Applying excessive force at the end stop may also break the internal wire.

- 1) Confirm the front wheels are positioned in straight ahead direction.
- 2) Rotate the roll connector counter-clockwise until it stops.
- 3) Rotate the roll connector clockwise approximately 2.5 turns until the “Δ” marks are aligned.

**NOTE:** When the roll connector comes to the center position, the orange roller (b) can be seen from the sight glass (a) as shown below.

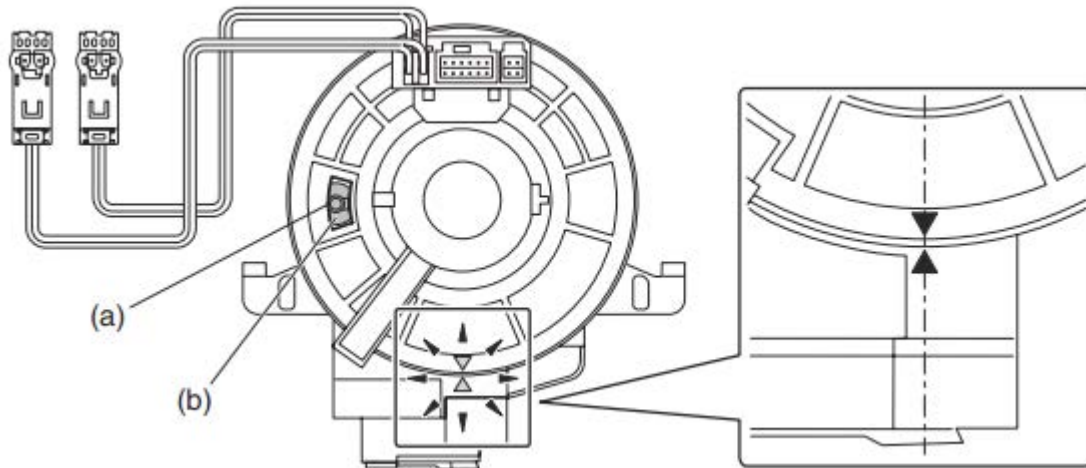

- Remove the engine under cover assembly.
- On H-6 models, remove the front exhaust pipe assembly following the procedure below:
- On H-4 models, proceed to “All Models Continued” below.

**Front Pipe Removal Procedure for H-6 Models:**

**CAUTION:** The exhaust system may be HOT.

- Disconnect the A/F and O2 Sensor wiring harness connectors.
- Remove the center exhaust pipe retaining nuts and spring bolts and separate the front exhaust pipe assembly from the center exhaust pipe. Retain the nuts, springs, and bolts for use at reassembly.



*Continued...*

- Remove the nuts holding the front exhaust pipe onto the cylinder heads. Retain these nuts for use at reassembly.

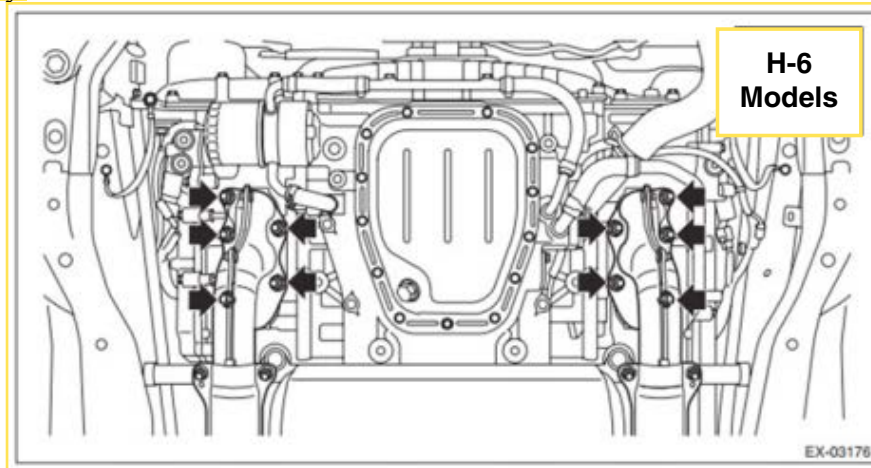

- **CAUTION:** The front exhaust pipe assembly is heavy and the heat shield edges can be very sharp. Use appropriate personal protective equipment (PPE) and care while lifting.
- Remove the front exhaust pipe from vehicle as an assembly and set aside.

#### **All Models Continued:**

- Place an alignment mark on the lower universal joint shaft and steering rack input shaft.
- Remove the 2 retaining bolts and universal joint shaft assembly.
- Remove the 2 bolts securing the steering column assembly.

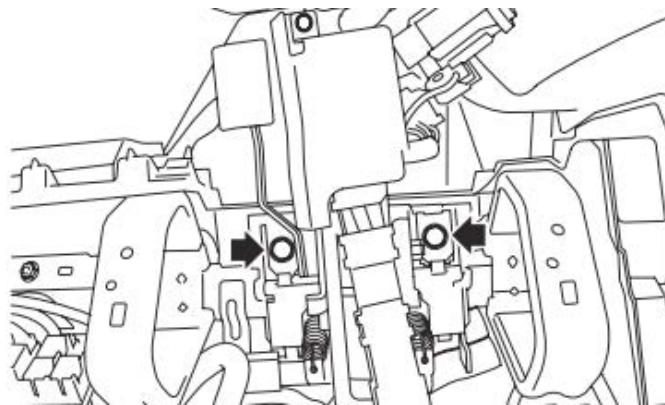

- **CAREFULLY** remove the steering column assembly taking special care to not dislodge the toe board grommet / bushing.
- Using a drill and screw extractor, remove the shear bolt securing the ignition lock to the steering column.

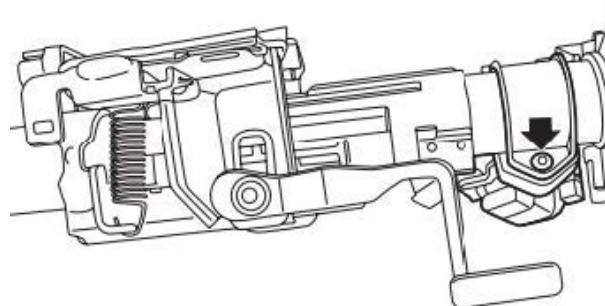

*Continued...*



- **CAREFULLY** Install the new steering column taking special care to not dislodge the toe board grommet / bushing. Tighten the 2 retaining bolts to 20 Nm (14.8 ft. lbs.).
- Transfer the ignition lock to the new steering column and secure with the new shear bolt.
- **CAREFULLY** reinstall the combination switch, roll connector, and steering angle sensor assemblies. **REMINDER:** If the position of the roll connector was disturbed, the center position adjustment procedure outlined above must be performed.
- Reconnect all the wiring harness connectors. **CAUTION:** On key-start vehicles, failure to reconnect the key lock solenoid connector will allow the ignition key to be removed from the ignition switch when the transmission shifter is not in park.
- Reinstall the universal joint shaft. Align the protrusion section (a) of the steering column shaft with the cutout (a) of the serration on the universal joint shaft as shown in the illustration on the left below. If not properly aligned, the upper bolt cannot be installed. Align the alignment mark on the steering rack end of the universal joint shaft with the mark on the steering rack input shaft and install the bolt but **DO NOT TIGHTEN IT**. The guide on the input shaft will slide into the split of the universal joint. Install the bolt and tighten to 24 Nm (17.7 ft. lbs.). Tighten the other bolt (on the column end) to 24 Nm (17.7 ft. lbs.).  
**IMPORTANT:** Always tighten the steering rack end retaining bolt first.

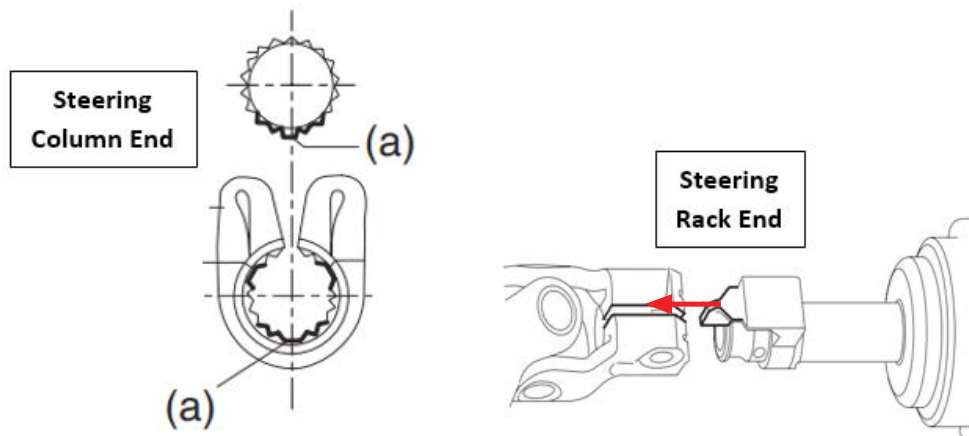

#### **H-6 Models:**

- Reinstall the front exhaust pipe assembly, always using new gaskets. Temporarily tighten the nuts holding the assembly to cylinder heads.
- Re-connect the center exhaust pipe, always using a new “donut” gasket. Torque the 2 spring bolt nuts to 18 Nm (13.3 ft. lbs.).
- Torque the nuts at the cylinder heads to 30 Nm (22.1 ft. lbs.) following the sequence shown in the illustrations below.
- Torque the 2 bolts holding the front pipe to the hanger bracket to 30 Nm (22.1 ft. lbs.).

*Continued...*

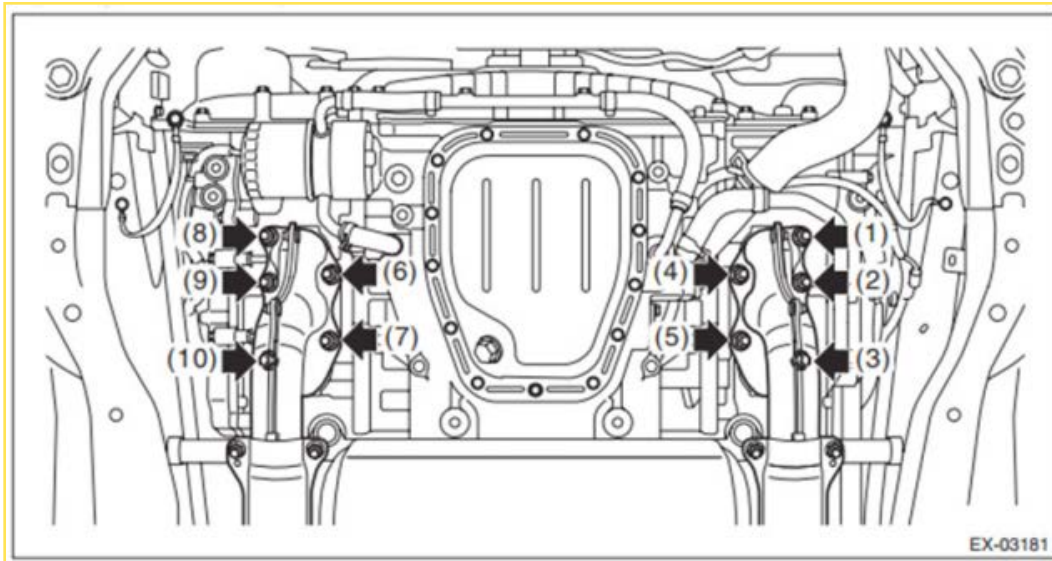

- Reconnect the A/F and O2 Sensor wiring harness connectors.

**All Models:**

- Reinstall the engine under cover.
- Reinstall the knee guard and tighten the 2 bolts to 7 Nm (5.2 ft. lbs.).
- Reconnect the harness connectors to the switches and reinstall the instrument panel lower trim cover.
- Reinstall the lower instrument panel under cover.
- Reinstall the steering column trim covers.
- Reinstall the steering wheel and torque the retaining nut to 39 Nm (28.8 ft. lbs.).
- Reconnect the harness connectors and reinstall the driver’s airbag module.
- Reconnect the battery cable to the battery sensor. Torque the 12mm nut to 7.5 Nm (5.5 ft. lbs.).
- **VERY IMPORTANT: ALWAYS confirm the steering column lock mechanism operates properly.**
  - If the steering column lock does not operate at all or
  - If there is excess steering wheel freeplay (more than 1/4” up to approximately 2 1/2”) when the steering column is locked, verify the proper column has been installed: an “02” on the label for key start models or an “03” on the label for push start models.
- Perform “VDC Sensor Midpoint Setting Mode” for the VDC system following the procedure below:

**NOTE:** The vehicle must be on a level surface with the wheels and steering wheel in the neutral (straight ahead) position.

- (1) Connect the Subaru Select Monitor 4 to the data link connector. **NOTE:** For detailed operation procedures, refer to “Application Help”.
- (2) Turn the ignition switch ON.
- (3) On «Start» display, select «Diagnosis».
- (4) On «Vehicle selection» display, input the target vehicle information and select «Confirmed».
- (5) On «Main Menu» display, select «Each System».

*Continued...*

- (6) On «Select System» display, select «Brake Control System» and select «Enter».
- (7) On «Select Function» display, select «Data Monitor».
- (8) On «Data monitor» display, select «Steering Angle Sensor», «Longitudinal G Sensor» and «Lateral G Sensor Output».

Confirm the steering angle sensor output value is within the range of following values:

- Model without EyeSight: -10 — 10 deg.
  - Model with EyeSight: -2 — 2 deg.
- 9) Confirm the output values for the Longitudinal G Sensor and Lateral G Sensor are -2 to 2 m/s.
  - 10) From «Work Support», select «VSC (VDC) Centering Mode», and perform the setting procedure according to the procedure displayed on the Subaru Select Monitor screen.
- **Reset the Auto-Up / Down feature of the power window system. Starting with the driver's window fully open (down):**
    - 1) Pull the switch up to close the window fully in steps (it will only close about 2" each time the switch is operated).
    - 2) Once the window is fully closed, pull up and hold the switch again for 1 second to complete the procedure.
    - 3) Repeat steps 1 and 2 for the passenger's front window using the passenger window switch.
  - Where applicable, confirm STARLINK returns automatically to the pre-repair status and an operator is contacted when pressing the RED SOS button. **Inform the Operator this is only a test.**
  - Reset the customer's radio station presets (and Navigation Favorites where applicable).
  - Turn the ignition key ON, depress the brake pedal and place the transmission selector in D range. Confirm the ignition key cannot be removed. If the key can be removed, the key lock solenoid harness connector is most likely not properly connected.
  - Drive the vehicle for 10 minutes and confirm there is no system malfunction, no warning light illumination and no DTCs set.

## CLAIM REIMBURSEMENT AND ENTRY PROCEDURES:

Credit to perform this service campaign will be based on the submission of properly completed repair order information. Retailers may submit claims through Vehicle Claim Entry on [subarunet.com](http://subarunet.com).

### NOTES:

- **Non-SSLP Rentals will now be reimbursed at the retailer's actual cost up to \$50 per day exclusively for this WTD-65 campaign. Please enter the full cost of the non-SSLP rentals in the Sublet amount field on the RECALL claim.**
- **SSLP rentals will continue to be reimbursed at \$35 per day. Continue to use the Rental field for reimbursement on the RECALL claim.**
- **As examples:**

- o A 4-day Non-SSLP rental for \$50 per day would be entered on the claim in the Sublet field for \$200 and NO amount in the Rental field.
- o A 4-day SSLP rental for \$35 per day would continue to use the Rental field with an entry of \$140 and do not enter any rental amount in the Sublet field.
- Sublet entries for Non-SSLP rental and off-site inspection must have comments detailing the amounts for each.
- For customers committing to purchase an affected unit, but needing immediate transportation while the unit is waiting for replacement parts, a rental car can be provided to the customer under the same terms listed above. Enter the rental amount on the RECALL claim.
- All documentation must be retained in accordance with current policies and procedures.
- In the event a customer obtained a rental vehicle on their own, rental reimbursement of up to \$50 will also be allowed through the Customer Retailer Services Dept. (CRS).
- The **ORIGINAL** 4-digit lot number must also be entered in the Miscellaneous Detail field when submitting for claim reimbursement. If illegible, enter “**ILLEGIBLE**” in that field.

Labor Description	Labor Operation #	Labor Time	Campaign Code	Claim Type
STEERING COLUMN- LOT# INSPECTION ONLY <b>NO PART REPLACEMENT REQUIRED</b>	A165-801	0.2	WTD-65	RC
STEERING COLUMN- LOT# INSPECTION & COLUMN ASSEMBLY REPLACEMENT (INCLUDES CENTERING THE STEERING WHEEL)	A165-802	1.1 for H4 Models		
		1.3 for H6 Models		

**IMPORTANT REMINDERS:**

- SOA strongly discourages the printing and/or local storage of service information as previously released information and electronic publications may be updated at any time.
- Always check for any open recalls or campaigns anytime a vehicle is in for servicing.
- Always refer to STIS for the latest service information before performing any repairs.