



Program Bulletin

CUSTOMER SATISFACTION PROGRAM

SUBJECT: Tire Pressure Monitor Not Installed in Spare Tire

MODELS: 2014-2016 Chevrolet Silverado
2014-2016 GMC Sierra
Equipped with Full Size Spare Tire and Road Wheel (SEO 00A)

.....
THIS PROGRAM IS IN EFFECT UNTIL APRIL 30, 2018.
.....

CONDITION

Certain 2014-2016 model year Chevrolet Silverado and GMC Sierra model vehicles equipped with a full size spare tire and road wheel (SEO 00A) may have been built without a Tire Pressure Monitoring (TPM) sensor installed in the spare tire. If the spare tire was to be used and the TPMS programmed to coordinate with the wheels in use, a tire pressure monitor system error would be displayed due to the lack of a sensor in the spare tire.

CORRECTION

Dealers are to install a TPM sensor in the spare tire.

VEHICLES INVOLVED

All involved vehicles are identified by Vehicle Identification Number on the Investigate Vehicle History screen in GM Global Warranty Management system. Dealership service personnel should always check this site to confirm vehicle involvement prior to beginning any required inspections and/or repairs. It is important to routinely use this tool to verify eligibility because not all similar vehicles may be involved regardless of description or option content.

For dealers with involved vehicles, a listing with involved vehicles containing the complete vehicle identification number, customer name, and address information has been prepared and will be provided to US and Canadian dealers through the GM GlobalConnect Recall Reports. Dealers will not have a report available if they have no involved vehicles currently assigned.

The listing may contain customer names and addresses obtained from Motor Vehicle Registration Records. The use of such motor vehicle registration data for any purpose other than follow-up necessary to complete this program is a violation of law in several states/provinces/countries. Accordingly, you are urged to limit the use of this report to the follow-up necessary to complete this program.

PART INFORMATION

Parts required to complete this recall are to be obtained from General Motors Customer Care and Aftersales (GMCC&A). Please refer to your “involved vehicles listing” before ordering parts. Normal orders should be placed on a DRO = Daily Replenishment Order. In an emergency situation, parts should be ordered on a CSO = Customer Special Order. A quantity limiter may be in effect.

Part Number	Description	Quantity/Vehicle
13581558	Sensor Asm. – Tire Pressure Indicator	1

SERVICE PROCEDURE

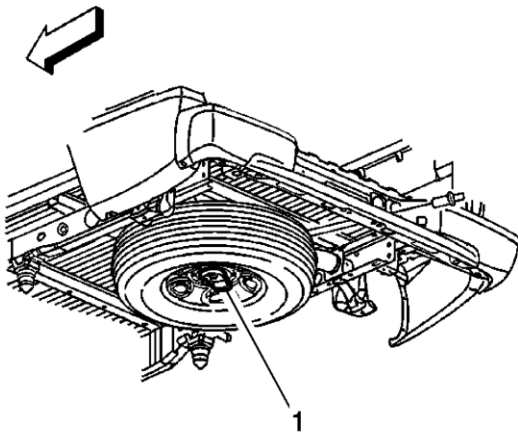

385766

1. If the vehicle is equipped with a spare tire stowage lock cylinder, open the spare tire lock cover on the bumper and using the ignition key, remove the lock before lowering the spare wheel hoist (1).
2. Locate and assemble the wrench kit.

Caution: Use only hand tools to lower and raise the spare tire hoist assembly. Do not use air tools. The use of air tools at high speeds will damage the spare tire hoist assembly.

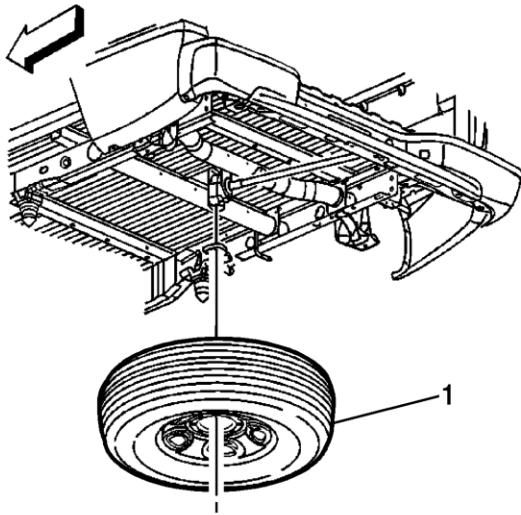

385791

3. Rotate the hoist shaft counterclockwise in order to lower the spare tire (1) to the ground. Continue to rotate the shaft until the spare tire can be pulled out from under the vehicle and removed. If the spare tire does not lower to the ground, the secondary latch is engaged causing the tire not to lower.

Note: It is not necessary to perform steps one and two of the *Tire Pressure Indicator Sensor Replacement* procedure, the spare wheel will already be removed from the vehicle. Step 7 of "Installation" is not required, DO NOT try to learn tire pressure sensor to the vehicle.

4. Install the tire pressure indicator sensor on the spare wheel tire assembly. Refer to *Tire Pressure Indicator Sensor Replacement* in SI.
5. Install the spare tire to the hoist.
6. Rotate the hoist shaft clockwise until the spare tire is in position.
7. Disassemble wrench kit and return to proper location.

COURTESY TRANSPORTATION

The General Motors Courtesy Transportation program is intended to minimize customer inconvenience when a vehicle requires a repair that is covered by the New Vehicle Limited Warranties. The availability of courtesy transportation to customers whose vehicles are within the warranty coverage period and involved in a product program is very important in maintaining customer satisfaction. Dealers are to ensure that these customers understand that shuttle service or some other form of courtesy transportation is available and will be provided at no charge. Dealers should refer to the General Motors Service Policies and Procedures Manual for Courtesy Transportation guidelines.

WARRANTY TRANSACTION INFORMATION

Submit a transaction using the table below. All transactions should be submitted as a ZFAT transaction type, unless noted otherwise.

Labor Code	Description	Labor Time	Net Item
9102162	Tire Pressure Indicator Sensor Replacement Base* ADD: Series 2500/3500	0.7 0.1	N/A

* Includes balancing the wheel/tire assembly.

CUSTOMER NOTIFICATION

General Motors will notify customers of this program on their vehicle (see copy of customer letter included with this bulletin).

DEALER PROGRAM RESPONSIBILITY

All new, used, GM Certified Used, courtesy transportation vehicles, dealer shuttle vehicles, etc. in dealers' possession and subject to this recall must be held and inspected/repared per the service procedure of this bulletin before customers take possession of these vehicles. Involved vehicles must be held and not delivered to customers, dealer-traded, released to auction, used for demonstration, or any other purpose.

All GM Certified Used vehicles currently in the dealers' inventory within the Certified Pre-Owned Inventory System (CPOIS) will be de-certified and must be held and remedied per the service procedure in this bulletin. Upon submitting an accepted/paid warranty transaction in the Global Warranty Management (GWM) system, the vehicle can be re-certified for sale within the CPOIS system, or once again be used in the CTP program.

Dealers are to service all vehicles subject to this program at no charge to customers, regardless of mileage, age of vehicle, or ownership, through April 30, 2018.

Customers who have recently purchased vehicles sold from your vehicle inventory, and for which there is no customer information indicated on the involved vehicle listing, are to be contacted by the dealer. Arrangements are to be made to make the required correction according to the instructions contained in this bulletin. A copy of the customer letter is provided in this bulletin for your use in contacting customers. Program follow-up cards should not be used for this purpose, since the customer may not as yet have received the notification letter.

In summary, whenever a vehicle subject to this program enters your vehicle inventory, or is in your facility for service through April 30, 2018, you must take the steps necessary to be sure the program correction has been made before selling or releasing the vehicle.



April 2016

This notice applies to your vehicle, **VIN:** _____

Dear General Motors Customer:

We have learned that your 2014-2016 model year Chevrolet Silverado or GMC Sierra equipped with a full size spare tire and road wheel may have been built without a Tire Pressure Monitoring sensor (TPM) installed in the spare tire. If the spare tire was to be used and the TPMS programmed to coordinate with the wheels in use, a tire pressure monitor system error would be displayed due to the lack of a sensor in the spare tire.

Your satisfaction with your GM vehicle is very important to us, so we are announcing a program to prevent this condition or, if it has occurred, to fix it.

What We Will Do: Your GM dealer will install a tire pressure monitor sensor in the spare tire. This service will be performed for you at **no charge until April 30, 2018**. After that, any applicable warranty will apply.

What You Should Do: To limit any possible inconvenience, we recommend that you contact your dealer as soon as possible to schedule an appointment for this repair. By scheduling an appointment, your dealer can ensure that the necessary parts will be available on your scheduled appointment date.

If you have any questions or concerns that your dealer is unable to resolve, please contact the appropriate Customer Assistance Center at the number listed below.

Division	Number	Text Telephones (TTY)
Chevrolet	1-800-630-2438	1-800-833-2438
GMC	1-866-996-9463	1-800-462-8583
Puerto Rico – English	1-800-496-9992	
Puerto Rico – Español	1-800-496-9993	
Virgin Islands	1-800-496-9994	

We sincerely regret any inconvenience or concern that this situation may cause you. We want you to know that we will do our best, throughout your ownership experience, to ensure that your GM vehicle provides you many miles of enjoyable driving.

Terry M. Inch
Executive Director
Global Connected Customer Experience

GLOBAL SAFETY FIELD INVESTIGATIONS
DCS4000
URGENT - DISTRIBUTE IMMEDIATELY

Date: April 15, 2016

Subject: 29110 - Customer Satisfaction
Tire Pressure Monitor Not Installed in Spare Tire

Models: 2014-2016 Chevrolet Silverado
2014-2016 GMC Sierra
Equipped with Full Size Spare Tire and Road Wheel (SEO 00A)

To: All Chevrolet and GMC Dealers

General Motors is releasing Customer Satisfaction Program 29110 today. The total number of U.S. vehicles involved is approximately 2,502. Please see the attached bulletin for details.

Customer Letter Mailing

The customer letter mailing will begin in the near future.

Global Warranty Management (GWM)

The Investigate Vehicle History (IVH) screen in the GWM system has been updated today April 15, 2016. A list of involved vehicles in dealer new inventory is attached to this message.

END OF MESSAGE
GLOBAL SAFETY FIELD INVESTIGATIONS