



# Program Bulletin

## CUSTOMER SATISFACTION PROGRAM

**SUBJECT:** Rear Trailing Arm Bolt Grease

**MODELS:** 2016 Chevrolet Malibu

.....  
THIS PROGRAM IS IN EFFECT UNTIL APRIL 30, 2018.  
.....

### CONDITION

Certain 2016 model year Chevrolet Malibu model vehicles may have been built with grease applied to the trailing arm to knuckle attachment bolts. Grease added under the shoulder of the bolts could result in the bolts slipping over time. If the bolts loosen there would be an increasing amount of noise from the rear suspension. Left unaddressed, the upper bolts could potentially back out completely. This would result in a noticeable swaying of the vehicles' rear end from road inputs while driving, and increased noise. The vehicle handling is not affected.

### CORRECTION

Dealers are to replace the four rear control arm to knuckle bolts. It will also be necessary to clean any grease from the bolt mounting surfaces.

### VEHICLES INVOLVED

All involved vehicles are identified by Vehicle Identification Number on the Investigate Vehicle History screen in GM Global Warranty Management system. Dealership service personnel should always check this site to confirm vehicle involvement prior to beginning any required inspections and/or repairs. It is important to routinely use this tool to verify eligibility because not all similar vehicles may be involved regardless of description or option content.

For dealers with involved vehicles, a listing with involved vehicles containing the complete vehicle identification number, customer name, and address information has been prepared and will be provided to US and Canadian dealers through the GM GlobalConnect Recall Reports. Dealers will not have a report available if they have no involved vehicles currently assigned.

The listing may contain customer names and addresses obtained from Motor Vehicle Registration Records. The use of such motor vehicle registration data for any purpose other than follow-up necessary to complete this program is a violation of law in several states/provinces/countries. Accordingly, you are urged to limit the use of this report to the follow-up necessary to complete this program.

## PART INFORMATION

Parts required to complete this recall are to be obtained from General Motors Customer Care and Aftersales (GMCC&A). Please refer to your “involved vehicles listing” before ordering parts. Normal orders should be placed on a DRO = Daily Replenishment Order. In an emergency situation, parts should be ordered on a CSO = Customer Special Order. A quantity limiter may be in effect.

**Note:** Use the vehicle identification number (VIN) and the GM Electronic Parts Catalog (EPC) to determine which part to order.

Part Number	Description	Quantity/Vehicle
11561297	Bolt	4
11610887	Bolt	2

## SERVICE PROCEDURE

Use the following procedure to replace the four rear control arm to knuckle bolts. It will also be necessary to clean any grease from the bolt mounting surfaces.

1. Raise the vehicle on a hoist. Refer to *Lifting and Jacking the Vehicle* in SI.
2. Remove both rear wheels. Refer to *Tire and Wheel Removal and Installation* in SI.



4479207

3. Support the left rear lower control arm with a tall jack stand.

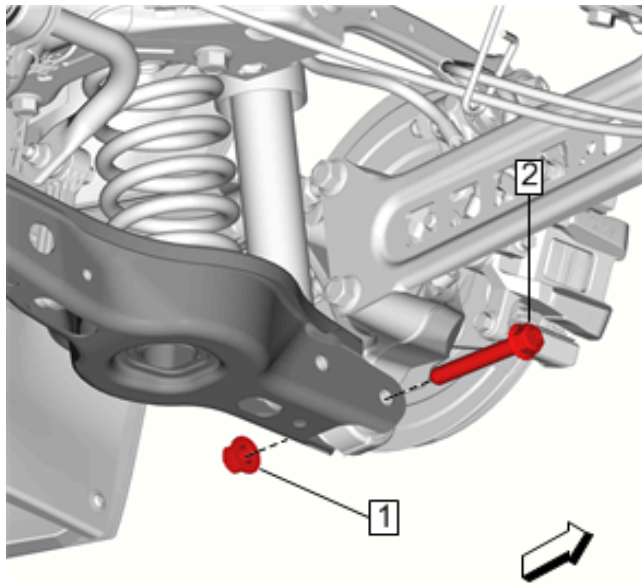

4200444

4. Remove the left control arm to knuckle nut (1) and bolt (2). Discard the bolt. **Do not remove the control arm to shock absorber bolt.**
5. Slightly lower the jack stand, allowing the lower control arm to separate from the knuckle. Only lower the control arm enough to access the lower trailing arm bolt removal.

**Note:** The control arm to shock bolt is pictured as being removed below for illustrative purposes **ONLY**. Do not remove the control arm to shock absorber bolt.

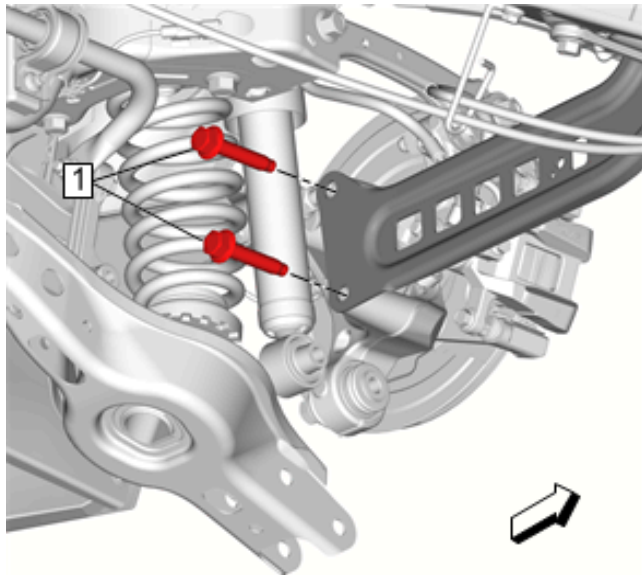

4196192

6. Remove the two left trailing arm to knuckle bolts (1). Discard the bolts.



4479212

7. Use an alcohol wipe to clean any grease from the bolt mounting area of the left trailing arm.

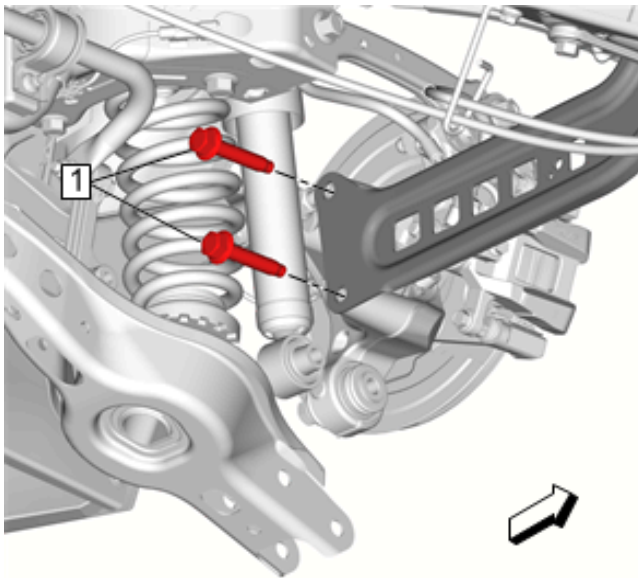

4196192

8. Install two new left trailing arm to knuckle bolts (1). **Tighten**, First pass: 160N.n (118 lb ft), final pass: (60-70 degrees).
9. Raise the jack stand and align the lower control arm with the knuckle.

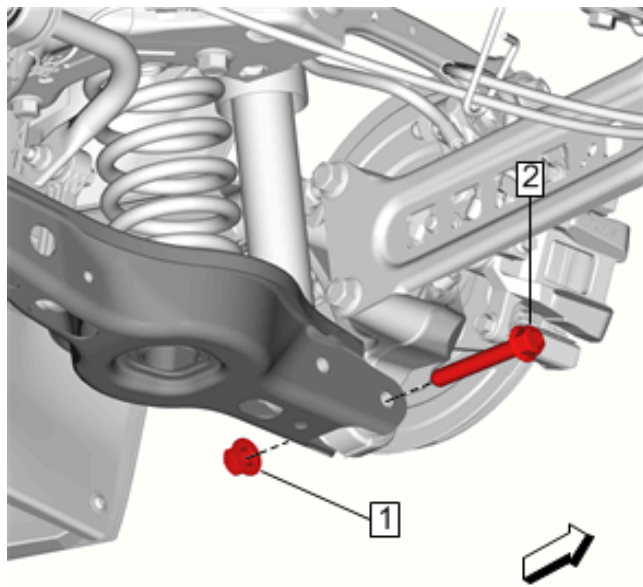

4200444

10. Install a new left control arm to knuckle bolt (2).
11. Install the left lower control arm nut (1). **Tighten**, First pass: 160N.n (118 lb ft), final pass: (90-105 degrees).
12. Repeat steps 3-11 on the right side of the vehicle.
13. Reinstall both rear wheels. Refer to *Tire and Wheel Removal and Installation* in SI.
14. Lower the vehicle. Refer to *Lifting and Jacking the Vehicle* in SI.

**COURTESY TRANSPORTATION**

The General Motors Courtesy Transportation program is intended to minimize customer inconvenience when a vehicle requires a repair that is covered by the New Vehicle Limited Warranties. The availability of courtesy transportation to customers whose vehicles are within the warranty coverage period and involved in a product program is very important in maintaining customer satisfaction. Dealers are to ensure that these customers understand that shuttle service or some other form of courtesy transportation is available and will be provided at no charge. Dealers should refer to the General Motors Service Policies and Procedures Manual for Courtesy Transportation guidelines.

**WARRANTY TRANSACTION INFORMATION**

Submit a transaction using the table below. All transactions should be submitted as a ZFAT transaction type, unless noted otherwise.

Labor Code	Description	Labor Time	Net Item
9102158	Clean Lubricant From Rear Suspension Trailing Arms, Install New Fasteners	1.0	N/A

**CUSTOMER NOTIFICATION**

General Motors will notify customers of this program on their vehicle (see copy of customer letter included with this bulletin).

## DEALER PROGRAM RESPONSIBILITY

All new, used, GM Certified Used, courtesy transportation vehicles, dealer shuttle vehicles, etc. in dealers' possession and subject to this recall must be held and inspected/repaired per the service procedure of this bulletin before customers take possession of these vehicles. Involved vehicles must be held and not delivered to customers, dealer-traded, released to auction, used for demonstration, or any other purpose.

All GM Certified Used vehicles currently in the dealers' inventory within the Certified Pre-Owned Inventory System (CPOIS) will be de-certified and must be held and remedied per the service procedure in this bulletin. Upon submitting an accepted/paid warranty transaction in the Global Warranty Management (GWM) system, the vehicle can be re-certified for sale within the CPOIS system, or once again be used in the CTP program.

Dealers are to service all vehicles subject to this program at no charge to customers, regardless of mileage, age of vehicle, or ownership, through April 30, 2018.

Customers who have recently purchased vehicles sold from your vehicle inventory, and for which there is no customer information indicated on the involved vehicle listing, are to be contacted by the dealer. Arrangements are to be made to make the required correction according to the instructions contained in this bulletin. A copy of the customer letter is provided in this bulletin for your use in contacting customers. Program follow-up cards should not be used for this purpose, since the customer may not as yet have received the notification letter.

In summary, whenever a vehicle subject to this program enters your vehicle inventory, or is in your facility for service through April 30, 2018, you must take the steps necessary to be sure the program correction has been made before selling or releasing the vehicle.



April 2016

This notice applies to your vehicle, **VIN:** \_\_\_\_\_

Dear General Motors Customer:

We have learned that your 2016 model year Chevrolet Malibu may have been built with grease applied to the trailing arm to knuckle attachment bolts. Grease added under the shoulder of the bolts could result in the bolts slipping over time. If the bolts loosen there would be an increasing amount of noise from the rear suspension. Left unaddressed, the upper bolts could potentially back out completely. This would result in a noticeable swaying of the vehicles' rear end from road inputs while driving, and increased noise. The vehicle handling is not affected.

Your satisfaction with your Malibu is very important to us, so we are announcing a program to prevent this condition or, if it has occurred, to fix it.

**What We Will Do:** Your GM dealer will replace the four rear control arm to knuckle bolts and clean any grease from the area. This service will be performed for you at **no charge until April 30, 2018**. After that, any applicable warranty will apply.

**What You Should Do:** To limit any possible inconvenience, we recommend that you contact your dealer as soon as possible to schedule an appointment for this repair. By scheduling an appointment, your dealer can ensure that the necessary parts will be available on your scheduled appointment date.

If you have any questions or concerns that your dealer is unable to resolve, please contact the appropriate Customer Assistance Center at the number listed below.

Division	Number	Text Telephones (TTY)
Chevrolet	1-800-630-2438	1-800-833-2438
Puerto Rico – English	1-800-496-9992	
Puerto Rico – Español	1-800-496-9993	
Virgin Islands	1-800-496-9994	

We sincerely regret any inconvenience or concern that this situation may cause you. We want you to know that we will do our best, throughout your ownership experience, to ensure that your Chevrolet Malibu provides you many miles of enjoyable driving.

Terry M. Inch  
Executive Director  
Global Connected Customer Experience

GLOBAL SAFETY FIELD INVESTIGATIONS  
DCS3994  
URGENT - DISTRIBUTE IMMEDIATELY

Date: April 11, 2016  
Subject: 29030 - Customer Satisfaction Program  
Rear Trailing Arm Bolt Grease  
Models: 2016 Chevrolet Malibu  
To: All Chevrolet Dealers

General Motors is releasing Customer Satisfaction Program 29030 today. The total number of U.S. vehicles involved is approximately 106. Please see the attached bulletin for details.

**Customer Letter Mailing**

The customer letter mailing will begin in the near future.

**Global Warranty Management (GWM)**

The Investigate Vehicle History (IVH) screen in the GWM system will be updated in the near future. A list of involved vehicles in new dealer inventory is attached to this message. Please hold all warranty transactions until the VIN appears in IVH.

END OF MESSAGE  
GLOBAL SAFETY FIELD INVESTIGATIONS