



Service Bulletin

File in Section: -
 Bulletin No.: 16-NA-350
 Date: October, 2016

TECHNICAL

Subject: Buzz or Rattle Noise from Door Trim Panel

Brand:	Model:	Model Year:		VIN:		Engine:	Transmission:
		from	to	from	to		
Chevrolet	Camaro	2016	2017			All	All

Involved Region or Country	North America, Korea, Europe and all N.A. Export Regions
Condition	Some customers may comment on a buzz or rattle type noise coming from the door trim panel.
Cause	This may be due to speaker vibration caused by high bass.

Correction

If you encounter a vehicle with the above concern, complete the following steps:

1. Remove the affected door trim panel. Refer to *Front Side Door Trim Replacement* in SI.

2. Once the door trim panel is removed, install flocking tape in the 6 locations along the door panel edge as shown above.
3. Reinstall the door trim panel and verify the concern is corrected.

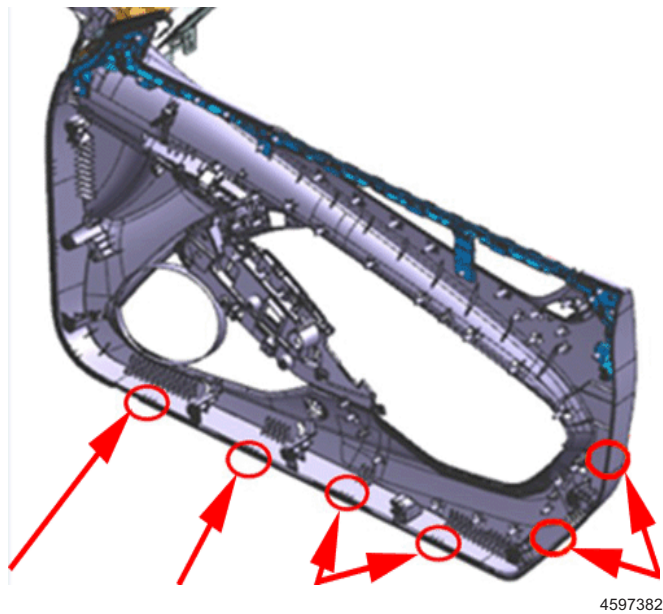

Parts Information

BRS Flocking tape is available from Kent Automotive at 1-888-YES-KENT or online at www.kent-automotive.com.

Description	Part Number
BRS Tape (Flocking Tape)	KT 13486

Warranty Information

For vehicles repaired under warranty, use:

Labor Operation	Description	Labor Time
1080408*	Apply BRS Tape to Door Trim Panel	0.4 hr
Add	Apply to Other Door Trim Panel	0.3 hr

*This is a unique Labor Operation for Bulletin use only.

Version	1
Modified	

GM bulletins are intended for use by professional technicians, NOT a "do-it-yourselfer". They are written to inform these technicians of conditions that may occur on some vehicles, or to provide information that could assist in the proper service of a vehicle. Properly trained technicians have the equipment, tools, safety instructions, and know-how to do a job properly and safely. If a condition is described, DO NOT assume that the bulletin applies to your vehicle, or that your vehicle will have that condition. See your GM dealer for information on whether your vehicle may benefit from the information.



WE SUPPORT VOLUNTARY
 TECHNICIAN
 CERTIFICATION