



# Service Bulletin

## TECHNICAL

**Subject:** A/C Inoperative, Blows Warm or Poor Performance Due to Low Refrigerant Charge, Freon Leak

**Attention:** This Bulletin also applies to any of the models that may be Export vehicles.

*This Bulletin replaces PIT5335A. Please discard PIT5335A.*

Brand:	Model:	Model Year:		Breakpoint:		Engine:	Transmission:
		from	to	from	to		
Buick	Enclave	2013	2016	Vehicles Built Prior to October 6, 2015		All	All
Chevrolet	Traverse	2013	2016				
GMC	Acadia	2013	2016				

<b>Condition</b>	Some customers may comment that the A/C is blowing warm, is exhibiting poor performance or of a general lack of air conditioning, or low charge.
<b>Cause</b>	The cause of this condition may be that, during operation, the auxiliary evaporator blower motor may emit brush dust that contains some copper particles. These particles could lead to accelerated corrosion to the auxiliary evaporator and a small refrigerant leak.
<b>Additional Options</b>	Equipped with Auxiliary Air Conditioning (RPO CJ2)

### Correction

After performing normal SI diagnostics, if the source of the leak is not found, check for a leak at the auxiliary evaporator core face. Remove the auxiliary blower control module and insert the GE 50078 Electronic Leak Detector to test for a leak, as well as employing the use of a black light.

If a leak is found, continue to the Service Procedure below to replace the evaporator, blower/fan assembly and thoroughly clean the interior of the evaporator case.

### Service Procedure

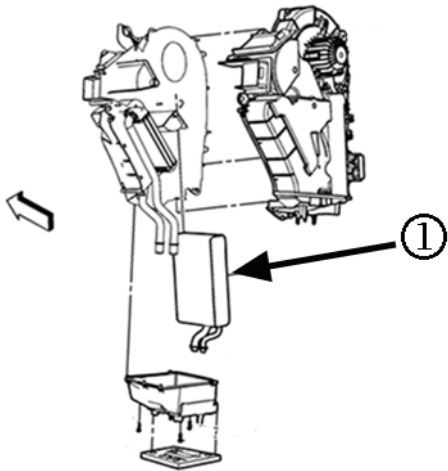

1. Remove the auxiliary a/c evaporator (1). Refer to *Auxiliary Air Conditioning Evaporator Replacement* in SI.

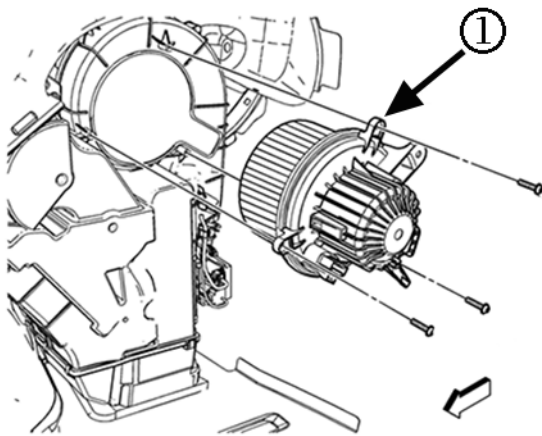

2. Remove the auxiliary blower motor assembly (1). Refer to *Auxiliary Blower Motor Replacement* in SI.
3. With the evaporator case disassembled, use compressed air to blow any copper dust from the inside of the case.

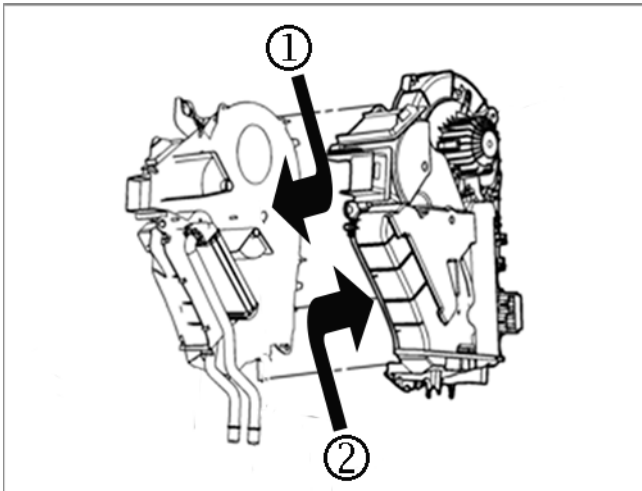

4. Use GM glass cleaner, P/N 19287404 (in Canada, 88865156), and a cloth to wipe down the linear power module and the inside surfaces, (1) and (2), of the case.
5. Install the new auxiliary a/c evaporator. Refer to *Auxiliary Air Conditioning Evaporator Replacement* in SI.
6. Install the new auxiliary blower motor assembly. Refer to *Auxiliary Blower Motor Replacement* in SI.

## Parts Information

Description	Part Number	Qty
MOTOR ASM-AUX BLO	23361388	1
EVAPORATOR ASM-AUX A/C	20827668	1
CLEANER, GLASS 18OZ AEROSOL (10% VOC) Glass Cleaner 500 g (Canada)	19287404 88865156	1

## Warranty Information

For vehicles repaired under warranty, use:

Labor Operation	Description	Labor Time
4417169	A/C System Analysis	Use Published Labor Operation Time
4480408*	Replace Auxiliary Evaporator, Blower Motor Assembly and Clean Case	2.8 hrs**

\*This is a unique Labor Operation for Bulletin use only.

\*\*This includes Diagnostic Analysis and Recover/Recharge R-134a A/C System

<b>Version</b>	1
<b>Modified</b>	

GM bulletins are intended for use by professional technicians, NOT a "do-it-yourselfer". They are written to inform these technicians of conditions that may occur on some vehicles, or to provide information that could assist in the proper service of a vehicle. Properly trained technicians have the equipment, tools, safety instructions, and know-how to do a job properly and safely. If a condition is described, DO NOT assume that the bulletin applies to your vehicle, or that your vehicle will have that condition. See your GM dealer for information on whether your vehicle may benefit from the information.



WE SUPPORT VOLUNTARY TECHNICIAN CERTIFICATION