

DISTRIBUTE TO: <input checked="" type="checkbox"/> Service Manager <input checked="" type="checkbox"/> Warranty Administrator	 TOYOTA Warranty Policy Bulletin	No.: POL14-12 Date: 12/16/14 Page: 1 of 9 REVISED 10/11/16
--	--	--

**SUBJECT: WARRANTY ENHANCEMENT PROGRAM (ZE7) PHASE 2:
WARRANTY EXTENSION FOR EXCESSIVE ENGINE OIL
CONSUMPTION FOR THE FOLLOWING VEHICLES:**

- **CERTAIN 2007-2009 MY CAMRY**
- **CERTAIN 2007-2011 MY CAMRY HYBRID**
- **CERTAIN 2007-2008 MY CAMRY SOLARA**
- **CERTAIN 2009-2011 MY COROLLA**
- **CERTAIN 2009-2013 MY COROLLA MATRIX**
- **CERTAIN 2006-2008 MY RAV4**
- **CERTAIN 2007-2010 MY SCION TC**
- **CERTAIN 2008-2015 MY SCION XB**

Background

Toyota has received some reports where vehicles may exhibit excessive engine oil consumption.

Toyota is now announcing the part replacement phase of Warranty Enhancement Program ZE7 for vehicles exhibiting excessive engine oil consumption.

Applicability

The engine is covered under the Toyota New Vehicle Limited Warranty for 5 years from the date of first use or 60,000 miles (whichever occurs first). However, Toyota is announcing a Warranty Enhancement Program to cover warranty work for parts replacement to address excessive engine oil consumption*.

***NOTE:** Eligibility for parts replacement under this Warranty Enhancement Program is dependent on the results of a dealer performed engine oil consumption test.

This Warranty Enhancement Program provides a Primary and Secondary coverage extension to the vehicle's "New Vehicle Limited Warranty" for replacement of parts related to Excessive Engine Oil Consumption. If the condition is verified, warranty work will be performed in accordance with applicable Technical Service Bulletin under the terms of this Warranty Enhancement Program.

Applicability (Continued)

Primary Coverage offers the warranty enhancement **until October 31, 2016 regardless of mileage.**

After the Primary Coverage expires, the **Secondary Coverage** is applicable for **ten (10) years from the date of first use or 150,000 miles, whichever occurs first.**

Verify VIN applicability for this warranty enhancement by checking TIS before completing any repairs.

Direct marketing of this warranty enhancement is strictly prohibited pursuant to the Toyota Warranty Policy 5.21, "Warranty Solicitation." Non-compliance with this policy may result in a claim debit.

This Warranty Enhancement Program is subject to all the terms and conditions set forth in the Toyota New Vehicle Limited Warranty, as detailed in Toyota Warranty Policies 4.1 and 4.17. For example, improper maintenance, lack of required maintenance, the use of fluids other than those specified in the Warranty and Maintenance Guide, or repairs to vehicles which are currently or were previously titled as "scrap," "salvage," or "dismantled" is not covered by the New Vehicle Limited Warranty or this Warranty Enhancement pursuant to Warranty Policy 4.17, "What Is Not Covered by the Toyota New Vehicle Limited Warranty".

This warranty enhancement provides coverage for the originally equipped engine. Prior to performing any repairs, verify the serial number on the engine matches the original engine serial number for that VIN. The original engine serial number can be found under Additional Vehicle Details in National Service History (NSH).

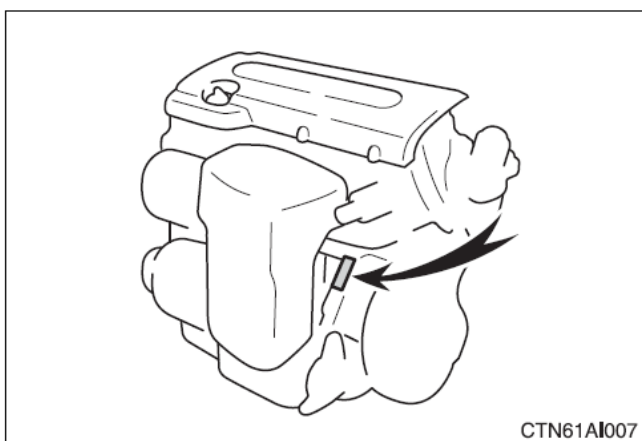
Serial Number Location:

CTN61AI007

Applicability (Continued)

Vehicles that received a genuine Toyota short block replacement that is pre counter measure on a prior repair are still eligible for this program. The Short Block part section of this warranty policy bulletin contains counter measured short block part numbers, please reference this information to determine if the previous replacement was counter measured.

Covered Vehicles

Not all vehicles within the specified model years are covered by this warranty enhancement. Verify VIN applicability for this warranty enhancement by checking TIS before completing any repairs.

Oil Consumption Testing and Documentation

Dealers will need to perform an engine oil consumption test to determine eligibility for part replacement.

Procedures for the oil consumption test can be found in T-SB-0158-14 (Toyota) and S-SB-0031-14 (Scion).

IMPORTANT: All warranty claims submitted will require oil consumption test documentation. The completed technician sign off sheet, provided in the TSB, must be attached to the claim.

If the vehicle does not qualify for warranty work based upon the oil consumption test performed, one (1) additional oil consumption test can be performed (free of charge under the Program) after 6 months or 5,000 miles has lapsed if the vehicle is still within the terms and conditions of the Warranty Enhancement Program. A maximum of two (2) engine oil consumption tests will be performed free of charge under this Warranty Enhancement Program.

Program Expiration and Claim Filing

Dealerships will be allowed to complete oil consumption repairs after the vehicle becomes ineligible for the program based on Primary or Secondary Coverage if the failed oil consumption test was completed/verified prior to the vehicle becoming ineligible. The repair order date for the failed test confirmation must be before the vehicle becomes ineligible.

Claim Submission

Claim Type	Opcode	Model	Description	Labor Time	OFP
Repair Program	ZE7INS*	ALL	Initiate Oil Consumption Test at Customer Request	0.0 hr./vehicle	N/A
	AHGC3B	ALL	Performed Oil Consumption Test – PASS – NOT ELIGIBLE	0.6 hr./vehicle	13211-#####
	AHGC3A	ALL	Performed Oil Consumption Test – FAIL – Perform TSB Repair at a later date		
	AHGC3P	Camry	Previously Performed Oil Consumption Test – Result Fail – Perform TSB Repair	14.8 hr./vehicle	
	AHGC3Q	Camry HV		15.5 hr./vehicle	
	AHGC3R	Corolla		14.2 hr./vehicle	
	AHGC3S	Matrix 2WD		14.2 hr./vehicle	
	AHGC3T	Matrix 4WD		14.7 hr./vehicle	
	AHGC3U	RAV4 2WD		15.6 hr./vehicle	
	AHGC3V	RAV4 4WD		16.3 hr./vehicle	
	AHGC3W	Solara		16.3 hr./vehicle	
	AHGC3X	Scion tC		16.6 hr./vehicle	
AHGC3Y	Scion xB	15.9 hr./vehicle			

- Dealers must attach the technician sign off sheet, provided in the TSB, to the warranty claim.
- **In the event the vehicle fails the Oil Consumption test and needs repairs, two claims must be filed.**
 - **The first claim should use opcode AHGC3A to claim the cost for completion of the Oil Consumption Test and to record that the vehicle failed the test.**
 - **The second claim should use opcodes AHGC3P - AHGC3Y to claim the repairs once they are completed. Opcode AHGC3B should only be used when a vehicle passes the Oil Consumption Test. There should be no corresponding repair claim when this opcode is used.**
- * Opcode “ZE7INS” is provided for claim submission to close out the R.O. when initiating the Oil Consumption Test. After the customer returns, the cost for completion of the Oil Consumption Test will be submitted with Opcode “AHGC3A/B” depending on the test results.

Note: If the vehicle is still under the New Vehicle Limited Warranty, submit the repair as a **Regular** warranty claim.

Sublet Submission

The Total cost for Engine Oil, Super Long Life Coolant, FIPG, Three bond 1324, Brake Cleaner and Plastigage should be claimed as sublet type "OF" per the following:

Model	ALL	Camry, Camry HV, RAV4, Scion xB	Corolla, Matrix, Scion tC
Op Code	AHGC3B	AHGC3P/Q/U/V/W/Y	AHGC3R/S/T/X
Actual Cost of Engine Oil Consumption Testing with 0W-20 Engine Oil (PN: 00279-0WQTE-01) up to 3 Quarts (Dealers must use quart bottles for testing. Bulk oil is not authorized for this operation.)	\$23.00	N/A	N/A
Actual Cost of Engine Oil Consumption Testing with 5W-20 Engine Oil (PN: 00279-1QT20-01) up to 3 Quarts (Dealers must use quart bottles for testing. Bulk oil is not authorized for this operation.)	\$14.00	N/A	N/A
Qty. of Oil Required for Replenishment After Repair	N/A	4.5 QT	4.0 QT
Actual Cost of Engine Oil Per Vehicle for Refill After Repair 0W-20 (Bulk Oil)	N/A	\$19.25	\$17.15
Actual Cost of Engine Oil Per Vehicle for Refill After Repair 5W-20 (Bulk Oil)	N/A	\$13.25	\$11.75
Actual Cost of Replenishment Super Long Life Coolant (SLLC) After Repair	N/A	\$34.30	\$34.30
FIPG (Seal Packing 103) PN: 00295-00103	N/A	\$11.75	\$11.75
Three Bond 1324 or Equivalent	N/A	\$6.00	\$6.00
Plastigage – Green (As Needed)	N/A	\$3.00	\$3.00
Brake Cleaner	N/A	\$12.50	\$12.50
Total Sublet Cost with 0W-20	\$23.00	\$86.80	\$84.70
Or			
Total Sublet Cost with 5W-20	\$14.00	\$80.80	\$79.30

Rental

A customer rental vehicle is available for 3 days through the Toyota Rent-A-Car (TRAC) program while the dealer performs the repair. Claim sublet type "RT" under Op Code AHGC3P through AHGC3Y at a maximum cost of \$35.00 per day.

In the event that parts are not available due to back order situation the dealer should claim the actual used rental days for long-term rentals (4 or more days) on a monthly basis using the rental opcodes below. The total rental sublet must be claimed using these opcodes before the repair claim is submitted. No rental sublet will be allowed on the final repair claim if long-term rental opcodes are used.

Claim Type	Opcode	Description	Sublet Type
Repair Program	AHGF3A	Vehicle Rental 1-30 Days	RT
	AHGF3B*	Vehicle Rental 31-60 Days	
	AHGF3C*	Vehicle Rental 61-90 Days	

* DSPM Authorization is required for rentals greater than 30 days or \$35.00 per day.

Short Block Claim Filing

Vehicles requiring a short block replacement will utilize the appropriate op code from the table above, AHGC3#.

All warranty claim submissions utilizing a short block will **require** an authorized case documented through the TAS hotline. Dealer must include the TAS case number on the claim when processing, any warranty claims for short block that do not include a TAS case authorizing short block replacement will be **denied**.

Important Note: For vehicles that experienced engine failure and require additional parts beyond the short block and TSB parts the TAS case will need to be updated with further information describing the extent of damage. Please include additional necessary replacement parts and pictures that justify the part replacement. This information will be used by the warranty department for warranty claim review.

When filing a claim for a short block repair, please be sure to utilize the engine overhaul gasket kit (without rings) or the individual required gaskets.

Replacement Parts

All parts replaced for this repair are subject to warranty parts recovery.

Model	Part Number	Part Name	Qty.	Applicable TSB
Camry	04004-11228	REPAIR KIT, PISTON RING	1	T-SB-0094-11 (Toyota) S-SB-0024-11 (Scion)
Camry HV	04004-11428			
Corolla	04004-11628			
Matrix	04004-11728			
RAV4	04005-42128			
Solara	04004-12228			
Scion tC	04004-11928			
Scion xB	04004-12128			
ALL	90915-YZZF1	FILTER, OIL	1	
ALL (Except Camry HV)	04004-79128-A0	PISTON	*	
	04004-79128-B0		*	
	04004-79128-C0		*	
Camry HV	13211-28150-A0		*	
	13211-28150-B0		*	
	13211-28150-C0		*	
Camry (PZEV Only)	17177-28040	GASKET, INTAKE MANIFOLD TO HEAD	1	
	17171-28020	GASKET, INTAKE MANIFOLD TO EXHAUST MANIFOLD INTAKE RUNNER	1	

*Refer to Repair Procedure in the TSB prior to ordering pistons to ensure the correct size is ordered.

Additional Parts (As Needed)

Model	Part Number	Part Name	Qty	Applicable TSB
ALL	13251-0H030-A0	PIN, PISTON	** (AS Needed)	T-SB-0094-11 (Toyota) S-SB-0024-11 (Scion)
	13251-0H030-B0			
	13251-0H030-C0			
	13201-09790-A0	ROD SUB-ASSY, CONNECTING	** (AS Needed)	
	13201-09790-B0			
	13201-09790-C0			
	13201-29686-A0			
	13201-29686-B0			
	13201-29686-C0			
	13281-0H031-01	BEARING, CONNECTING ROD	**(8 As Needed)	
	13281-0H031-02			
	13281-0H031-03			

** If Needed, Refer to Repair Procedure in TSB prior to ordering to ensure the correct size is ordered.

Short Block Parts (Special Authorization Required)

All replacement short block assemblies have been placed on Manual Allocation Control (MAC). If the dealer determines a short block is required, authorization through the TAS hotline will be required. Please refer to the Short Block Release Authorization flow chart for additional procedure information. If determined appropriate one of the following parts should be ordered:

Model	Part Number	Description	Qty
Camry	11400-28510	BLOCK ASSY, SHORT	1 (As Needed)
Solara			
Corolla			
Corolla Matrix			
RAV4			
Scion tC			
Camry HV	11400-28471		

For Scion xB models there are two different short block assembly part numbers depending on the Engine Manufacturing Plant location. Please reference the 3rd digit of the engine serial number to determine the appropriate short block part to order.

Engine Serial Location:

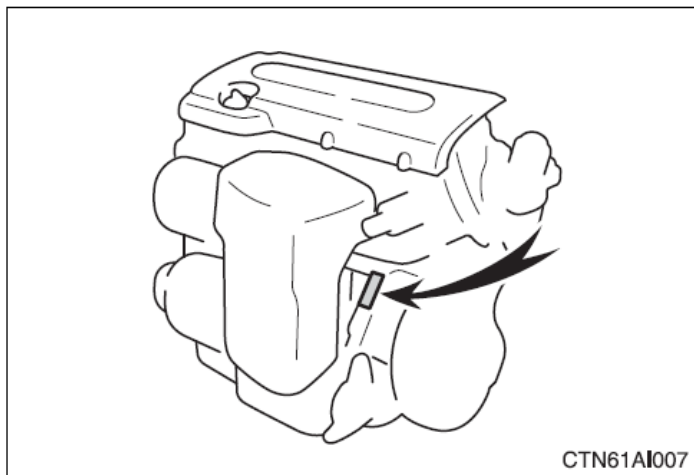

Model	3 rd Engine Serial Digit	Part Number	Description	Qty
Scion xB	H or J or L	11400-28510	BLOCK ASSY, SHORT	1 (As Needed)
	C or D or F	11400-0H151		

Customer-Paid Repairs or Replacement of Components

If a customer has previously paid for repair to address excessive engine oil consumption, please have them mail a copy of the repair order, proof-of-payment, and proof-of-ownership* to the following address for reimbursement consideration:

**Toyota Motor Sales, U.S.A., Inc.
Customer Experience Center, WC10
19001 South Western Avenue
Torrance, CA 90509**

The customer name, address, and telephone number(s) should be included in the request. The customer should allow 6-8 weeks for processing.

*Please refer to the Reimbursement Checklist attached to the sample owner letter for required documentation details.

TAS Case Documentation Requirements:

- Include a good call back number
- Include this statement in the Condition Log **“Warranty Enhancement Program ZE7 – Request for Short Block”**
- Brief explanation of concern/reason for short block replacement (examples below)
 - Loss of Cross Hatch Pattern
 - Vertical Scoring of Cylinder Walls
 - Rod through block, etc
- Attach clear pictures illustrating concern with the block
- Attach a picture of the vehicle VIN plate.
- Engine Serial Number
- Leave the TAS cases status as open

Submit the completed case in TAS; allow 2 hours for TAS to review the case. After 2 hours of time, check the TAS case for status. If a decision has been made to replace the short block the case will be marked closed.

If the request for short block is denied or additional information is required the case will be left open. Please refer to the condition log for further instructions.

Important Note: For vehicles that experienced engine failure and require additional parts beyond the short block and TSB parts the TAS case will need to be updated with further information describing the extent of damage. Please include additional necessary replacement parts and pictures that justify the part replacement. This information will be used by the warranty department for warranty claim authorization.

NOTE: TAS hours of operation are 5:00 A.M to 5:00 P.M. PST Monday through Friday. Contact number: 1-855-716-7676

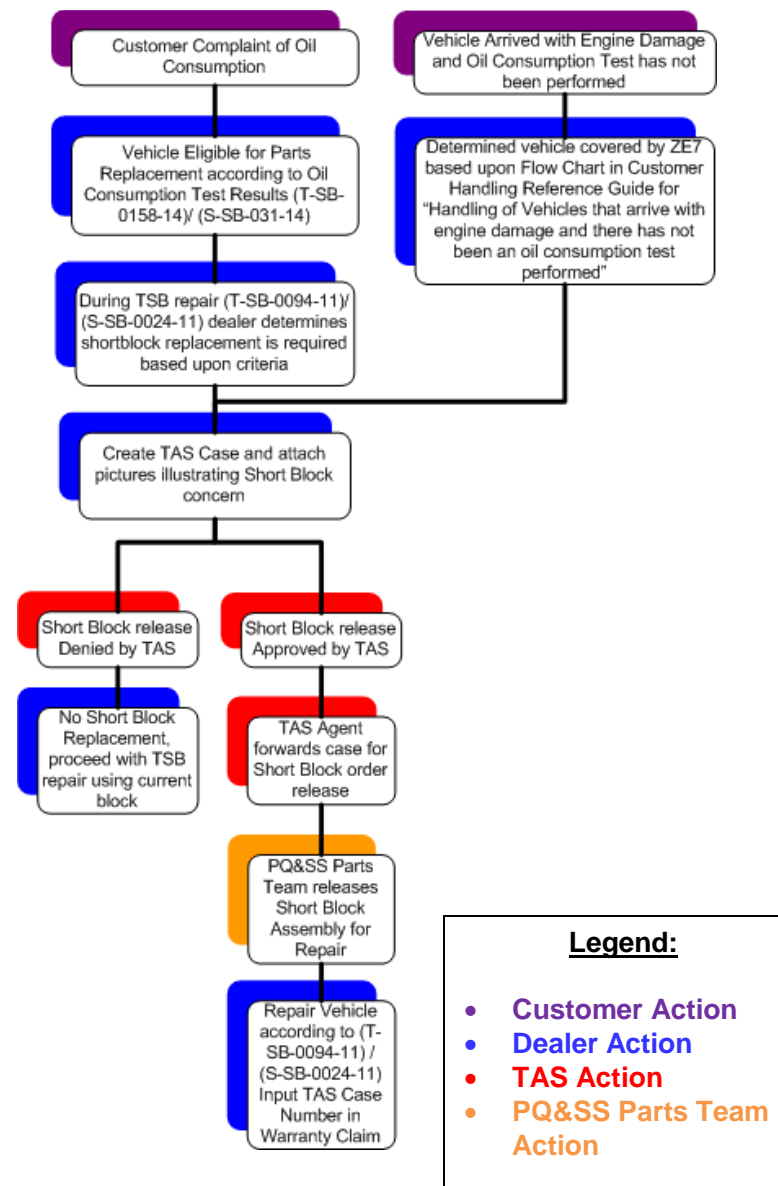

Legend:

- Customer Action
- Dealer Action
- TAS Action
- PQ&SS Parts Team Action