

Service Update

16029 Engine High Pressure Fuel Pump and Fuel Rail Low Torque



Reference Number: N16206438

Release Date: October 2016

Revision: 00

Attention: This service update includes vehicles in dealer inventory and customer vehicles that return to the dealership for any reason. This bulletin will expire at the end of the involved vehicle's New Vehicle Limited Warranty period.

Make	Model	Model Year		RPO	Description
		From	To		
Cadillac	ATS	2016	2016	LGX	3.6L V-6 Engine
Cadillac	CTS	2016	2016	LGX	3.6L V-6 Engine
Cadillac	XT5	2017	2017	LGX	3.6L V-6 Engine
Chevrolet	Camaro	2016	2016	LGX	3.6L V-6 Engine

Involved vehicles are marked "open" on the Investigate Vehicle History screen in GM Global Warranty Management system. This site should always be checked to confirm vehicle involvement prior to beginning any required inspections and/or repairs.

Condition	The high pressure fuel pump or fuel rail fastener(s) may have been improperly tightened during manufacturing. Fuel could leak from the fuel pump or fuel rail causing the vehicle to go into reduced power mode. If this occurs DTC P228C, P228D or P00C6 will set, causing the Check Engine Light to be illuminated.
Correction	Using the VIN list provided below, tighten the appropriate fastener as outlined in the service procedure section and, if required, replace the fuel pump or fuel feed intermediate pipe.

VIN	Location of Low Torque Fastener
1GYKNCRS6HZ114294	Fuel Rail
1G6AX5SS5G0196008	Fuel Pump
1G1FB1RS5G0189956	Fuel Pump
1G1FD1RS1G0168709	Fuel Rail
1G1FB1RS5G0172767	Fuel Rail
1G1FD1RS1G0181590	Fuel Pump
1G1FB3DS8G0186374	Fuel Rail
1G6AE5SS2G0119649	Fuel Pump

Parts

Quantity	Part Name	Part No.
1	Fuel Feed Intermediate Pipe	12673714
1	Fuel Pump	12647366
1	Fuel Injection Fuel Rail - RH	12671079
1	Fuel Injection Fuel Rail - LH	12671078
3	Bolt	11588726
1	Heater Outlet Pipe Gasket	12647308
1	Fuel Injector Seal Kit	12657373
1	Intake Manifold Seal	12648665
1	Engine Coolant	12346290 (US) 10953464 (Canada)

Due to the small number of vehicles involved, dealers are encouraged not to order recall parts for use as shelf stock.

Service Update

16029 Engine High Pressure Fuel Pump and Fuel Rail Low Torque



Warranty Information

Labor Operation	Description	Labor Time	Trans. Type	Net Item
9102603	Inspect Torque of Fuel Pump Bolts Add: Replace Fuel Pump	2.4 0.4	ZFAT	N/A
9102604	Inspect Torque of Fuel Injection Fuel Rail Cadillac XT5 Chevrolet Camaro Add: Replace Fuel Injection Fuel Rail Cadillac XT5 Chevrolet Camaro	0.7 1.6 1.1 1.8	ZFAT	N/A

Service Procedure

Torque Inspection of Fuel Pump Bolts

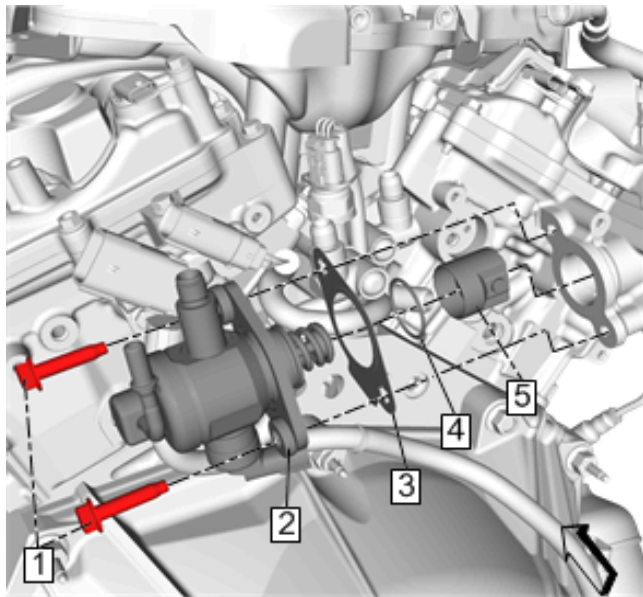

4095372

1. Verify the torque of the high pressure fuel pump bolts (1) is 15 Nm (11 lb ft). Refer to *Fuel Pump Replacement* in SI.
 - If the torque of the high pressure fuel pump bolts is 15 Nm (11 lb ft) or GREATER, torque the bolts to 25 Nm (18 lb ft).
 - If the torque of the high pressure fuel pump bolts is LESS THAN 15 Nm (11 lb ft), replace the fuel pump and fuel feed intermediate pipe

Service Update

16029 Engine High Pressure Fuel Pump and Fuel Rail Low Torque



Torque Inspection of Fuel Injection Fuel Rail Bolts

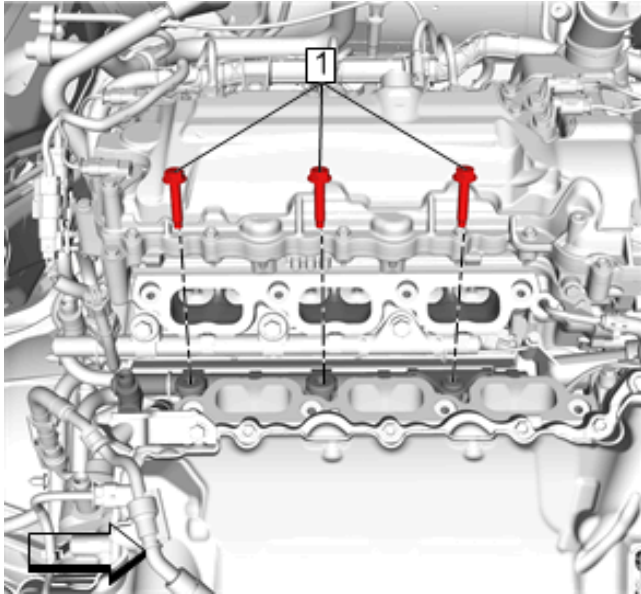

4091979

Fuel injection fuel rail bolts – bank 1.

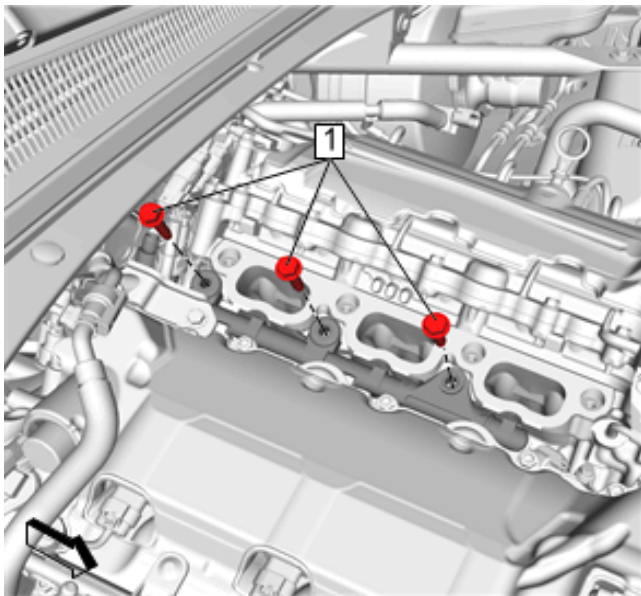

4093321

Fuel injection fuel rail bolts – bank 2.

1. Verify the torque of the fuel injection fuel rail bolts (1) is 20 Nm (15 lb ft). Refer to *Fuel Injection Fuel Rail Assembly Replacement - Bank 1* or *Fuel Injection Fuel Rail Assembly Replacement - Bank 2* in SI.
 - If the torque of the fuel injection fuel rail bolts is 20 Nm (15 lb ft) or GREATER, torque the bolts to 25 Nm (18 lb ft).
 - If the torque of the fuel injection fuel rail bolts is LESS THAN 20 Nm (15 lb ft), replace the fuel injection fuel rail, bolts, and the fuel feed intermediate pipe.

Service Update

16029 Engine High Pressure Fuel Pump and Fuel Rail Low Torque



Dealer Responsibility

Whenever a vehicle subject to this service update enters your vehicle inventory, or is in your facility for service in the future, and the vehicle is still covered under the New Vehicle Limited Warranty, you must take the steps necessary to be sure the service update correction has been made before selling or releasing the vehicle.

All new, used, GM Certified Used, courtesy transportation vehicles, dealer shuttle vehicles, etc. in dealers' possession and subject to this bulletin must be held and inspected/repared per the service procedure of this bulletin before customers take possession of these vehicles. Involved vehicles must be held and not delivered to customers, dealer-traded, released to auction, used for demonstration, or any other purpose.

All GM Certified Used vehicles currently in the dealers' inventory within the Certified Pre-Owned Inventory System (CPOIS) will be de-certified and must be held and remedied per the service procedure in this bulletin. Upon submitting an accepted/paid warranty transaction in the Global Warranty Management (GWM) system, the vehicle can be re-certified for sale within the CPOIS system, or once again be used in the CTP program.

GM bulletins are intended for use by professional technicians, NOT a "do-it-yourselfer". They are written to inform these technicians of conditions that may occur on some vehicles, or to provide information that could assist in the proper service of a vehicle. Properly trained technicians have the tools, equipment, safety instructions, and know-how to do a job properly and safely. If a condition is described, **DO NOT** assume that the bulletin applies to your vehicle, or that your vehicle will have that condition. See your dealer for information on whether your vehicle may benefit from the information.



**We Support
Voluntary Technician
Certification**

GLOBAL SAFETY FIELD INVESTIGATIONS
DCS4223
URGENT - DISTRIBUTE IMMEDIATELY

Date: October 21, 2016

Subject: 16029 - Service Update
Engine High Pressure Fuel Pump and Fuel Rail Low Torque

Models: 2016 Cadillac ATS
2016 Cadillac CTS
2017 Cadillac XT5
2016 Chevrolet Camaro
Equipped with 3.6L V-6 Engine (LGX)

To: All General Motors Dealers

General Motors is releasing Service Update 16029 today. The total number of U.S. vehicles involved is 6. Please see the attached bulletin for details.

Global Warranty Management (GWM)

The Investigate Vehicle History (IVH) screen in the GWM system will be updated October 21, 2016. Please hold all warranty transactions until the VIN appears in IVH.

END OF MESSAGE
GLOBAL SAFETY FIELD INVESTIGATIONS