

**PREVOST**

**WARRANTY  
BULLETIN**

**WB15-19F**

DATE :	OCTOBER 2015	SECTION :	22 - HVAC
EXPIRATION:	OCTOBER 2017		
SUBJECT :	<b>BITZER A/C COMPRESSOR VIBRATION – ADDITION OF A REINFORCEMENT BRACKET TO THE MOUNTING</b>		

Rev F: THIS WARRANTY BULLETIN SUPERSEDES PREVIOUS VERSIONS  
March 22, 2016 BOM: now kit WB15-19. WB15-19 supersedes 457769.

**APPLICATION**

<b>NOTICE TO SERVICE CENTERS</b> <i>Verify vehicle eligibility by checking warranty bulletin status with <b>SAP</b> or via <b>ONLINE WARRANTY SYSTEM</b> available on Service / Warranty tab of Prevost website.</i>	
Model	VIN
H3-41, H3-45 coaches Model Year : 2013 - 2015	 2PCH33494 <u>DC712272</u> And from 2PCH33499DC71 <u>2364</u> up to 2PCH33495FC71 <u>2994</u> incl.
H3-45 VIP motorhomes Model Year : 2013 - 2015	The following individual vehicles: 2PCVS3499 <u>DC712399</u> , 2PCVS3499 <u>DC712452</u> , 2PCVS3490EC71 <u>2468</u> , 2PCVS3494EC71 <u>2473</u> , 2PCVS3490EC71 <u>2549</u> , 2PCVS3496EC71 <u>2555</u> , 2PCVS3493EC71 <u>2612</u> , 2PCVS3495EC71 <u>2689</u> And from 2PCVS3495FC71 <u>2709</u> up to 2PCVS349XFC71 <u>2950</u> incl. <b>equipped with Bitzer A/C compressor</b>
X3-45 coaches Model Year : 2013 - 2016	2PCG33491 <u>DC735388</u> , 2PCG33492 <u>DC735433</u> From 2PCG33497EC73 <u>5459</u> up to 2PCG33494GC73 <u>5910</u> incl.
X3-45 VIP motorhomes Model Year : 2014 - 2015	2PCBS3499 <u>FC735798</u> , 2PCBS3498 <u>FC735808</u> , 2PCBS3490 <u>FC735818</u>
X3-45 VIP commercial use Model Year : 2015	From 2PCCS349XFC73 <u>5748</u> up to 2PCCS3496FC73 <u>5911</u> incl. <b>equipped with Bitzer A/C compressor</b>
XLII-45 Entertainer Model Year: 2013	2PCYS3492 <u>DC735374</u> , 2PCYS3490 <u>DC735468</u>
<b>This bulletin does not necessarily apply to all the above-mentioned vehicles, some vehicles may have been modified before delivery. The owners of the vehicles affected by this bulletin will be advised by a letter indicating the Vehicle Identification Number (VIN) of each vehicle concerned.</b>	

## DESCRIPTION

On the vehicles affected by this bulletin, vibration is causing damage to A/C compressor and compressor harness connectors. Addition of a reinforcement bracket to Bitzer A/C compressor is needed to increase the installation stiffness and reduce vibration amplitude.

### IMPORTANT NOTE FOR VEHICLES INCLUDED IN WB14-06:

This previous bulletin must have been completed before starting WB15-19.

If bulletin WB14-06 has been completed, you should see on the engine curbside harness support two *fitting arrangements for pressure sensors and switches SE23; SE29 SE24.*

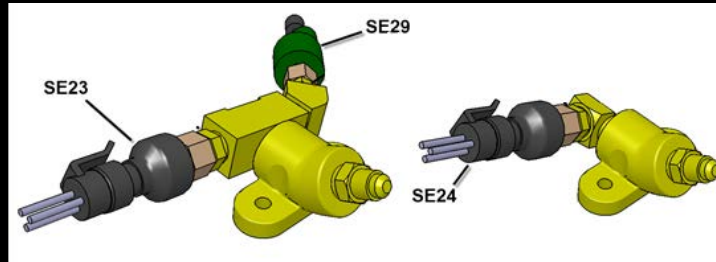

If required, the latest version of WB14-06 is available through Prevest Technical Publications site.

## MATERIAL

Order **WB15-19** which includes:

Part No.	Description	Qty
069206	HARNESS, A/C COMPRESSOR (1x)	1
062490	DOUBLE WALL SHRINK TUBE .250" - .125" / BLACK, 6" long	2
069356	DECAL	1
457675	REINFORCEMENT BRACKET, A/C COMPRESSOR	1
502949	SCREW, BUTTON HD HEX SOCKET M10 x 25lg SS [LINNIG CLUTCH]	1
504637	CABLE TIES, NYLON 3/16" x 13"	20
507664	CABLE TIE, NYLON 3/16" x 11" DOUBLE LOOP HEAD	5
509815	TREE MOUNT, FT	1
562228	BUTT SPLICE 16-14 AWG	2
950576	COIL, UNLOADER ASSEMBLY	1
950577	O-RING, COMPRESSOR UNLOADER COIL	1
5001616	SOCKET HEAD CAP SCREW M10-1.5X25 LG [LANG CLUTCH]	2

Bulk material that may be required:

Part No.	Description	Qty
950533	COIL, ELECTROMAGNETIC CLUTCH, [LANG CLUTCH]	1
-	MOLYCOTE <i>G-rapid-plus</i> 400ml spray can [LANG CLUTCH] ( <a href="http://krayden.com/buy/dc-g-rapid-plus-400ml-spray-can.html">http://krayden.com/buy/dc-g-rapid-plus-400ml-spray-can.html</a> )	20ml

**NOTE**

Material can be obtained through regular channels.

**TOOLS**

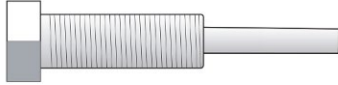

Lang clutch extractor tool # 7770159

---

## REPAIR PROGRESS CHECKLIST

---

• **MATERIAL**

- MATERIAL REQUIRED IS IN STOCK
- OPTIONAL MATERIAL IS AVAILABLE

• **REINFORCEMENT BRACKET INSTALLATION**

- LANG CLUTCH INSPECTED AND REPLACED IF APPLICABLE
- SHAFT SEAL DRAIN TUBE REINSTALLED ON OPPOSITE SIDE
- REINFORCEMENT BRACKET INSTALLED
- BOLTS **C** & **E** TIGHTENED AS PER PRESCRIBED TORQUE
- WARNING DECAL AFFIXED
- CLUTCH COIL MOUNTING SCREWS TIGHTENED AS PER PRESCRIBED TORQUE
- ROTOR MOUNTING SCREW **G** TIGHTENED AS PER PRESCRIBED TORQUE
- BELT TENSION ADJUSTED
- BELT TENSIONER SCREW AND NUT PROPERLY TIGHTEN

• **UNLOADER COIL REPLACEMENT**

- NEW CLIP-ON COIL INSTALLED

• **HARNESS #069206 INSTALLATION**

- BRAND NEW HARNESS INSTALLATION NOT REQUIRED
- or
- BRAND NEW HARNESS INSTALLED AND PROPERLY SECURED
  - CONNECTOR L199 SCREW TIGHTENED
  - CONNECTOR S09 REMOVED

## PROCEDURE



### DANGER

Park vehicle safely, apply parking brake, stop engine. Prior to working on the vehicle, set the ignition switch to the OFF position and trip the main circuit breakers equipped with a trip button. On the Commuter type vehicles, set the battery master switch (master cut-out) to the OFF position.

## REINFORCEMENT BRACKET INSTALLATION

1. Loosen bolt (A).
2. Unscrew and remove bolt (B).
3. Remove the drive belt tensioner.
4. Remove the drive belts.

*Note: Keep hardware for later use*

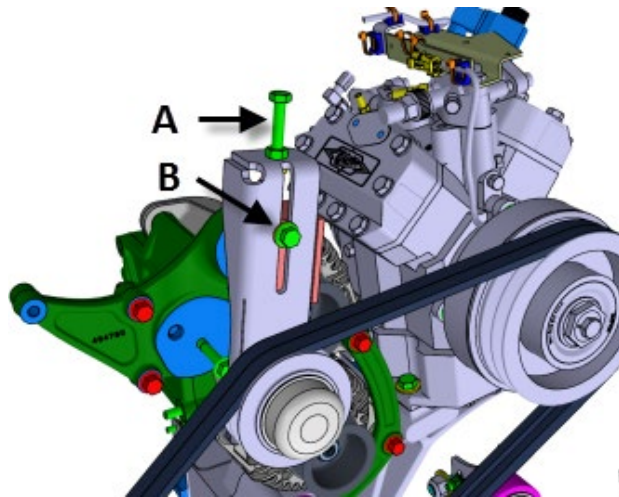

5. Unscrew and remove bolt (C).
6. Discard block (D).

*Note: Keep hardware for later use*

*Make sure they are in good condition*

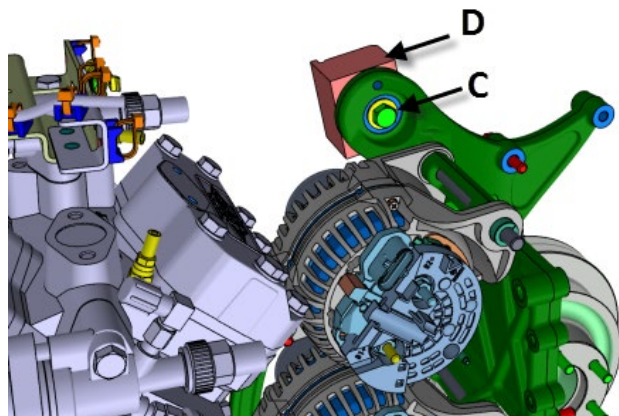

7. AT THIS POINT, IDENTIFY THE TYPE OF CLUTCH INSTALLED ON YOUR VEHICLE.

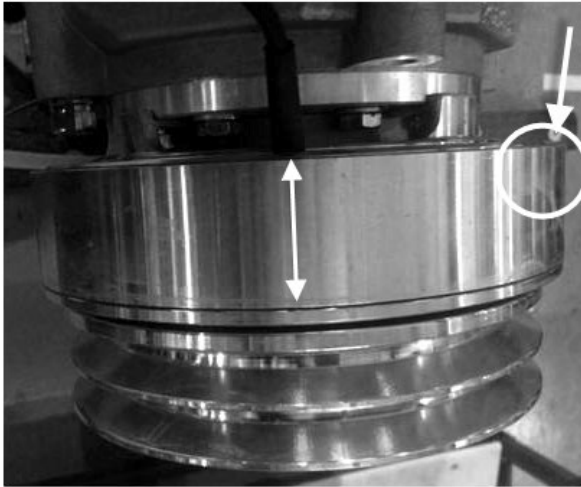

**LANG TYPE: SHARP EDGE COIL**

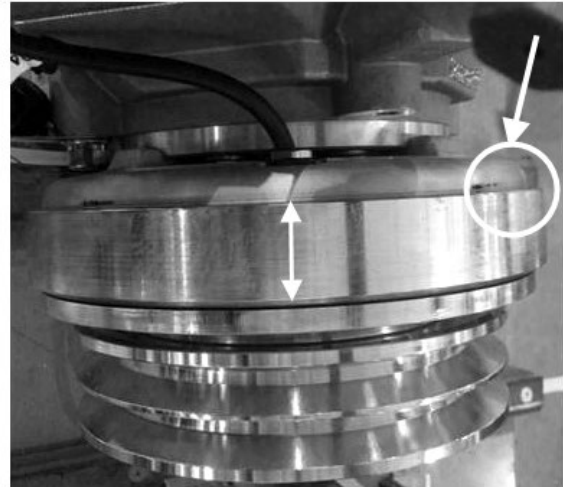

**LINNIG TYPE: ROUND EDGE COIL**

8. As an alternate way to confirm **LANG** Type clutch, locate "LANG" engraving on the hub center.

*Note for this type:*

In addition to kit #457769, confirm you have two #5001616 socket head cap screws in your available material.

These additional screws will be used to install the reinforcement bracket on the compressor.

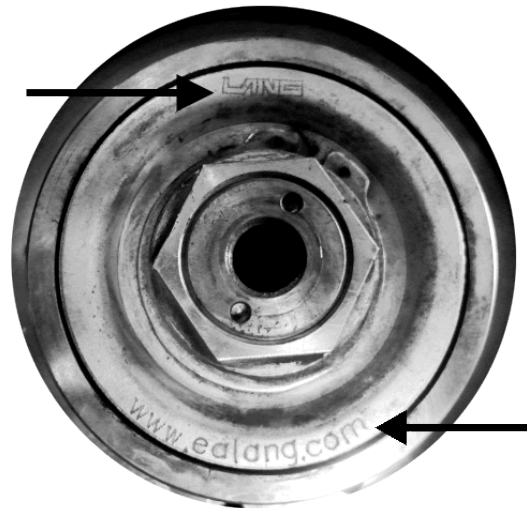

9. If a **LINNIG** Type clutch is installed, refer to "LINNIG ELECTROMAGNETIC CLUTCH INSTALLATION / REMOVAL" at the end of this document.

*LANG clutches only*

10. Remove the LANG electromagnetic clutch assembly.

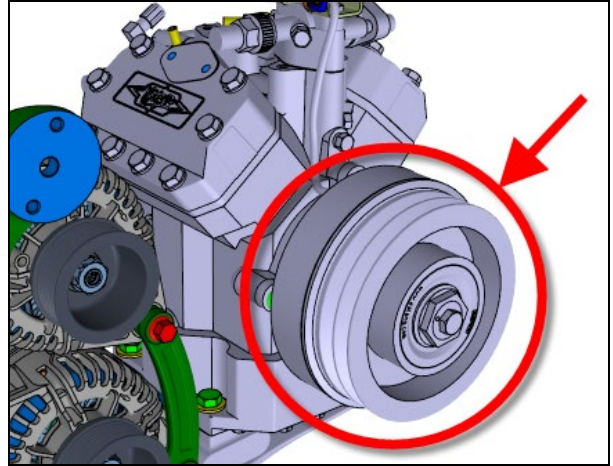

*LANG clutches only*

10.1. Hold the rotor with the appropriate wrench. Loosen and remove the M12 rotor mounting screw.

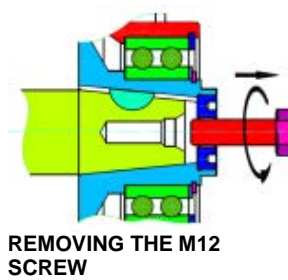
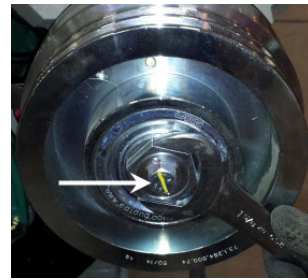

**REMOVING THE M12 SCREW**

*LANG clutches only*

10.2. Use tool #7770159 and screw it in the straining washer.

*If the tool is not available, use an M16x50 mm hex head bolt. (Prevost 5001372)*

Tap with a soft hammer. The rotor will detach from the compressor shaft.

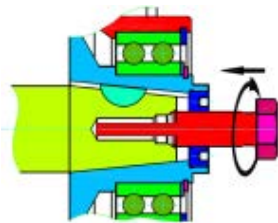

**PULL OFF THE ROTOR WITH TOOL or M16 BOLT**

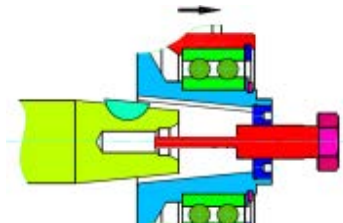

**TAKE OFF THE ROTOR**

10.3. Remove the rotor.

10.4. Loosen the fastening screws (4x) of the coil and pull the coil off the retainer.

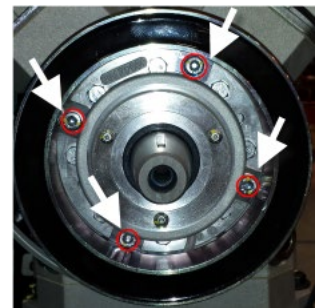

LANG clutches only

10.5. Check the date code on the clutch pulley. If it is before S05 (May 2015), install a new coil #950533 in replacement of this one.

Do not re-install the clutch at this step. This will be done further in the bulletin.

Date code engraving location has changed beginning of 2015 (image below).

10.6. IF CLUTCH DOES NOT HAVE A DATE CODE, OR CODE FORMAT IS DIFFERENT FROM BELOW, DO NOT REPLACE THE COIL

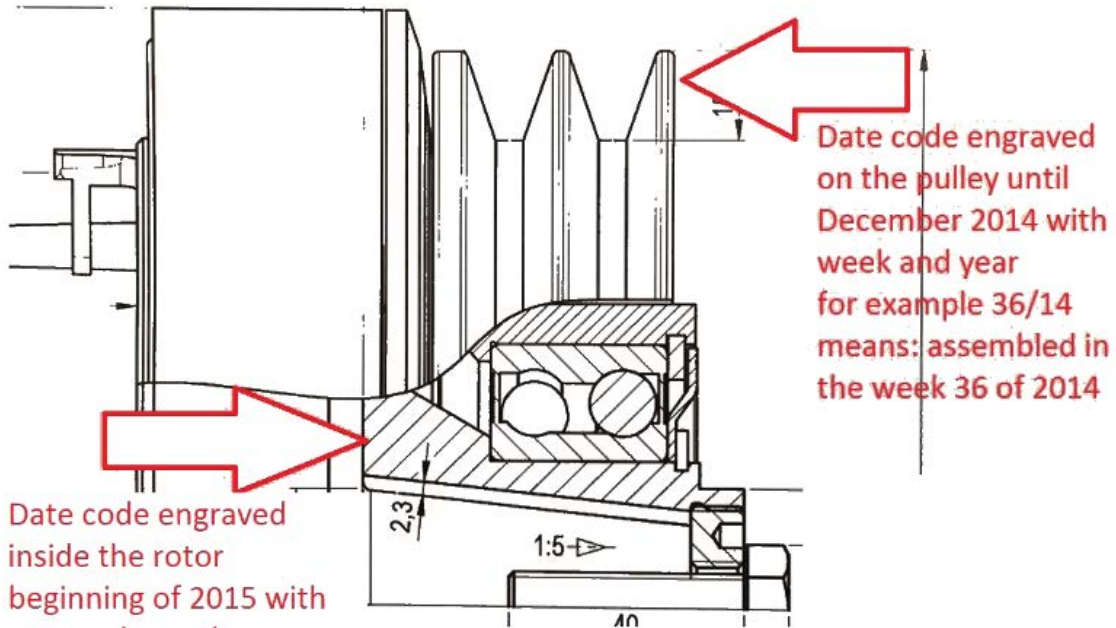

Date code engraved inside the rotor beginning of 2015 with year and month for example S02  
S= 2015  
02= February

Date code engraved on the pulley until December 2014 with week and year for example 36/14 means: assembled in the week 36 of 2014

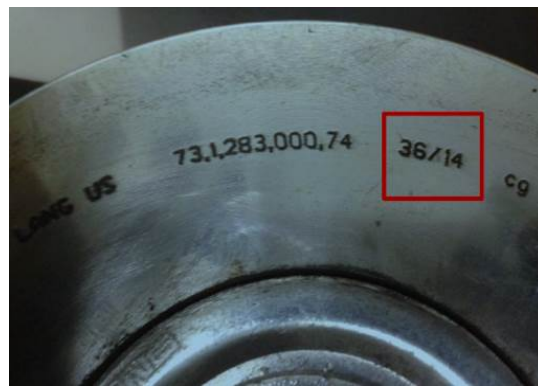

11. Remove the existing shaft seal drain tube and support.
12. Reinstall on the opposite side as seen on the image on the right.

*Note: Use existing hex socket head bolt and lock washer. Use blue Loctite 243 on threads.*

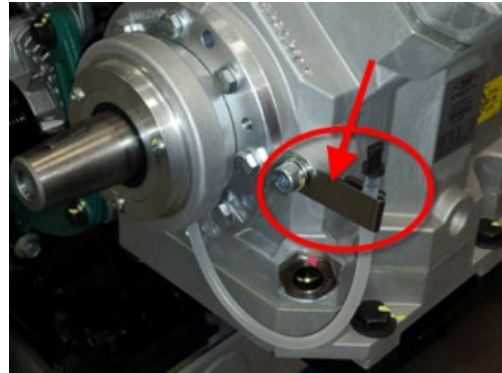

13. Install new reinforcement bracket #457675 as shown using previously removed hardware (bolt (C) and flat washer). DO NOT tighten at this moment.

*Note: Use blue Loctite 243 on threads.*

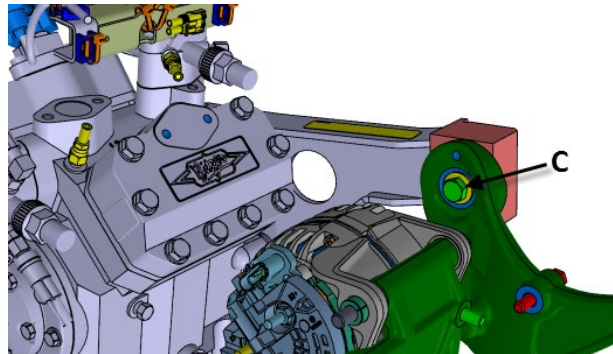

### LANG clutches:

- 13.1. Carry on with the installation of new reinforcement bracket #457675 as shown. Use two "cylindrical head" socket cap screws #5001616 (E).

*Tighten to 40 lbf-ft (43 N-m)*



*Note: Use blue Loctite 243 on threads.*

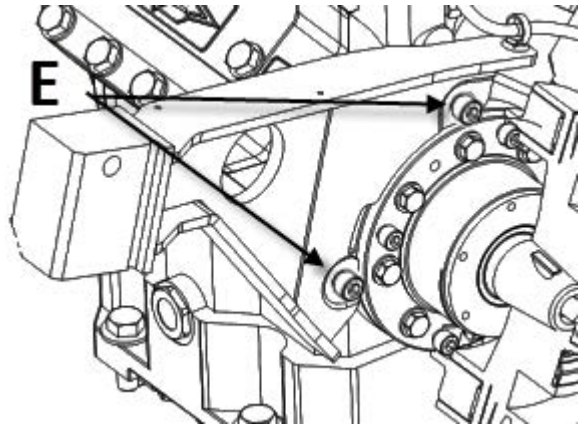

### LINNIG clutches only:

- 13.2. Carry on with the installation of new reinforcement bracket #457675 as shown.

- 13.3. Any standard bolt head would interfere with the coil body, therefore use two button head cap screws #502949 provided in the kit (E).

*Tighten to 32 lbf-ft (43 N-m)*

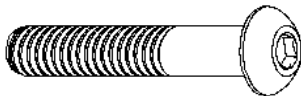

*Note: Use blue Loctite 243 on threads.*

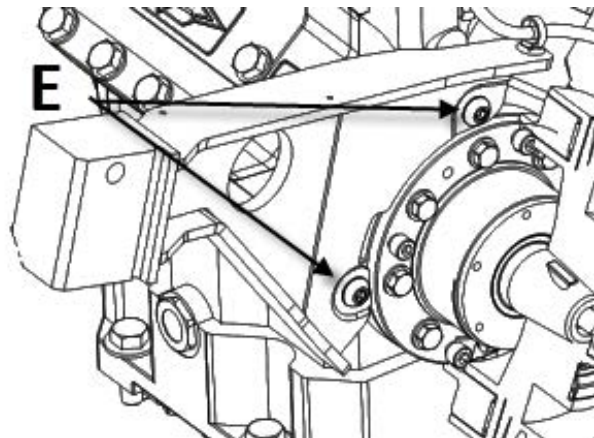

14. Tighten bolt in location (C).

**C= 74 lbf-ft (100 N-m)**

*Note: If bolts are difficult to drive in hole, the compressor may be moved. Loosen the compressor mounting bolts (4x) at the base. Tighten compressor mounting bolts to 74 lbf-ft. (100 N-m)*

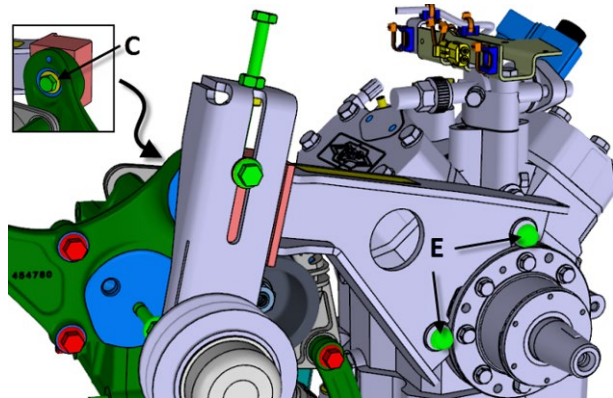

15. Reinstall tensioner, bolt and washer (B) and bolt and nut (A). You don't have to tighten these bolts as the belt tension adjustment will be done later in this procedure.

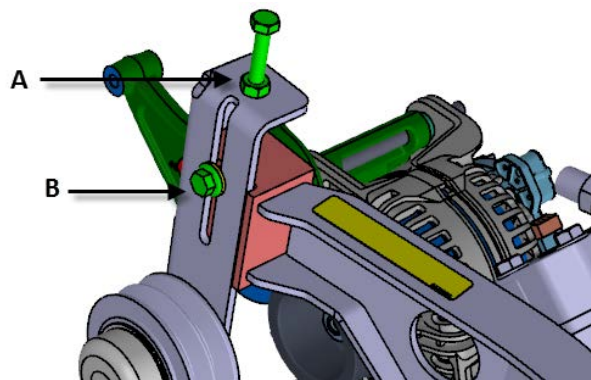

16. Apply decal #069356 where indicated on the image.

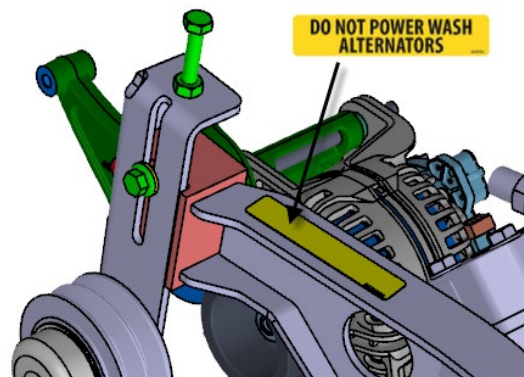

17. Install nylon tie mount #509815 where indicated on the image.

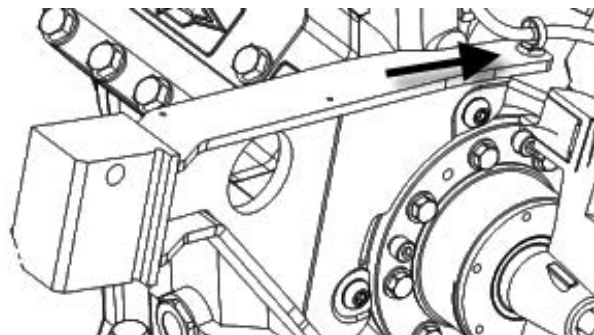

18. Reinstall the electromagnetic clutch coil. Position cable lead on the right side. Slip the coil on the retainer on the compressor flange. Fasten the coil with 4 screws to the compressor.

Coil mounting screws (F): **22 lbf-ft (30 N-m)**.  
Use blue Loctite 243.

**Caution:** Pay attention to the precise seat of the coil. A non-observance may cause the destruction of the clutch components during operation.

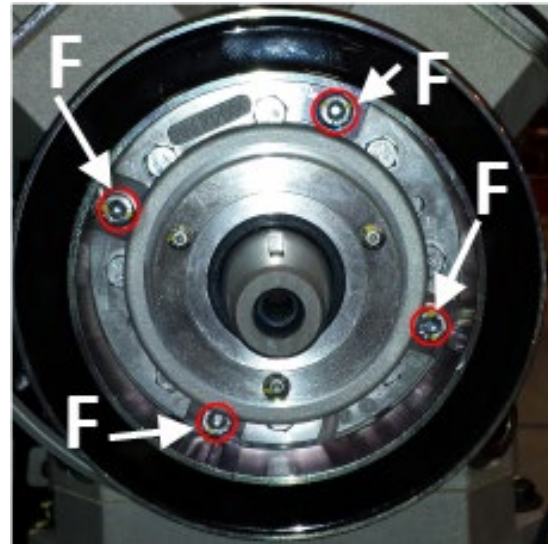

19. Mount the clutch on the shaft end.

*The flange and the shaft end of the compressor must be free from dirt. Apply high temperature approved assembly grease on the shaft end for easy dismounting of the clutch.*

*Lang recommends the use of Molykote G-rapid-plus or Molykote P 40.*

20. Carefully mount the rotor on the shaft end by hand.

*Never use a hammer for pressing the rotor on.*

To avoid damaging the bore of the rotor, feel the engagement of the key in the keyway and slip the rotor on the shaft end of the compressor till reaching the stop.

The Woodruff key on the shaft end and the groove in the location hole of the rotor must be flush.

21. Fasten the rotor to the shaft end by using the M12 screw and by holding-up with a wrench on the rotor.

Rotor mounting screw (G): **60 lbf-ft (81 N-m)**  
Use blue Loctite 243.

22. Turn rotor by hand and pay attention to the free run and the generation of noises. In case of grinding or similar noises, dismount the clutch and check installation.

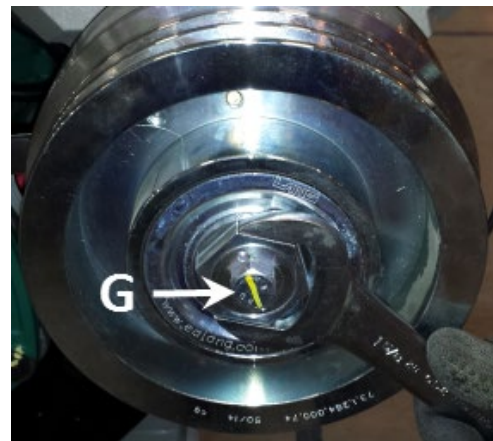

### 23. Reinstall the drive belts.

On vehicles not equipped with an auxiliary alternator (i.e. 2 identical belts), belt tension should be within this range:

*A belt strand tension gauge is needed*  
90-100 lbs new belts (mean of 2 belt values)  
75-85 lbs used belts (mean of 2 belt values)

On vehicles equipped with an auxiliary alternator (i.e. 2 different belts), belt tension should be within this range:

*A belt strand tension gauge is needed*  
150-160 lbs new belts (mean of 2 belt values)  
120-130 lbs used belts (mean of 2 belt values)

Hand-tighten bolt (B). Apply loctite on bolt (B). Adjust belt tension using bolt (A). Use the jam nut to prevent rotation of bolt (A). When proper tension is achieved, tighten bolt (B) to **43 lbf-ft.** (58 N-m)

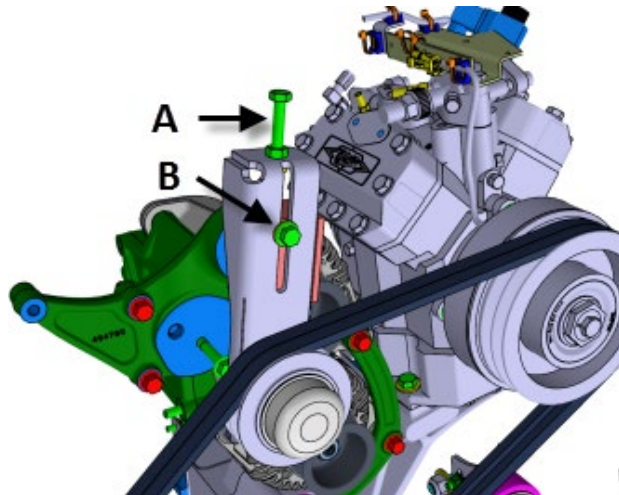

## UNLOADER COIL REPLACEMENT

A new “clip-on” type unloader coil must be installed in order to avoid unloader failure.

1. Loosen the screw securing the connector to the coil and then unplug the connector (A). Keep the screw and the connector rubber gasket for later use.
2. Unscrew the aluminum cap and discard.
3. Remove the plastic capture nut and discard.
4. Remove the coil and discard.
5. **Keep the O-ring** on the stem.

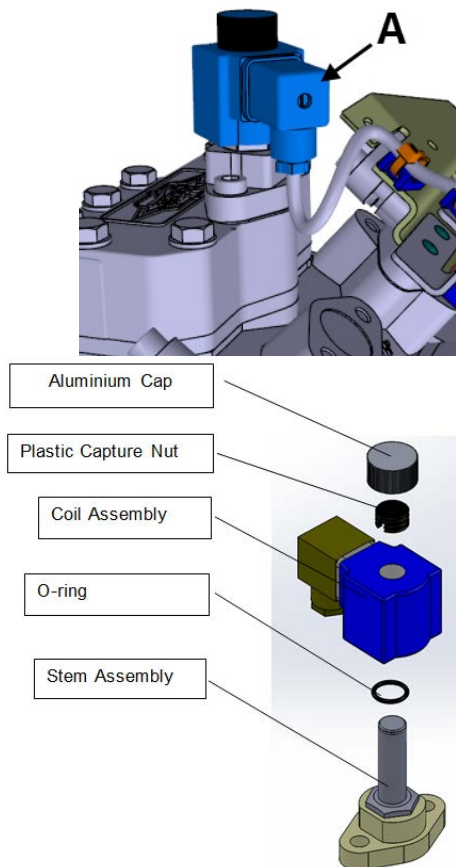

6. Install the new clip-on coil on the stem.
7. Slide the coil over the stem assembly with the O-ring at the base of the stem.



## HARNESS #069206 INSTALLATION

**Skip the harness installation** if a brand new harness has been installed recently while performing WB14-06.

If you're not installing a new harness, DO NOT throw it away. Keep it as spare part for later use if required.

1. While proceeding with one connector at a time, remove the existing A/C compressor harness simultaneously as you install the new harness. The new harness should be installed and routed like the one being removed.

*So9: A/C electromagnetic clutch*

*Se29: A/C pressure switch*

*L199: the R.H. side cylinder unloader coil*

*Se23: high side pressure transducer*

*Se24: low side pressure transducer*

*C228: other C228 connector half*

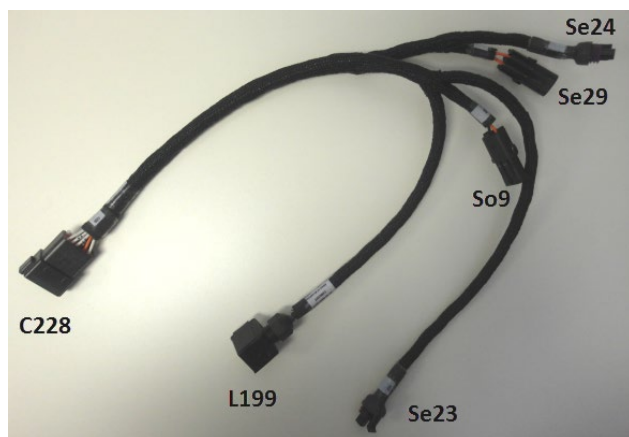

Take special care to route the harness according to the following figures.

Refer to best practices at the end of this document. Prefer larger, heat resistant cable ties over small cable ties to limit the "pinch effect".

Secure the cable on the cable tie mounts where applicable.

2. Install new harness **069206**. Connect **L199** to the unloader coil. Tighten the screw securing connector L199 to the coil.
3. Secure the cable on the cable tie mounts.

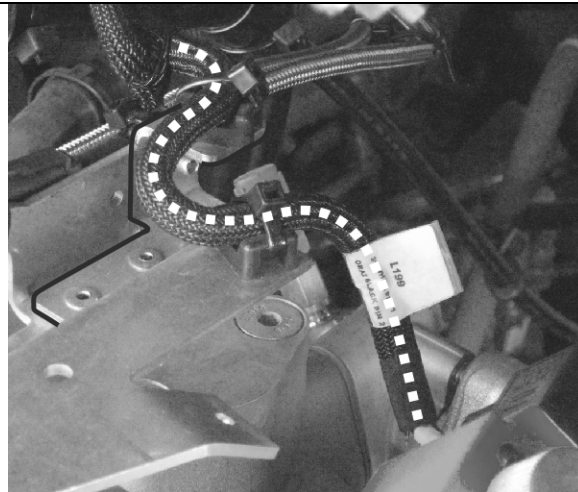

**Electromagnetic clutch connector So9. The clutch should be connected directly (hard wired) to the harness without using So9.**

4. Write down wire color matching then cut the clutch connectors **So9** on harness and compressor.
5. Slip shrink tube #062490 over each wire. Slip an additional shrink tube over cable insulation.
6. Refer to table below if required to match wire colours. (According to VIN of vehicle).

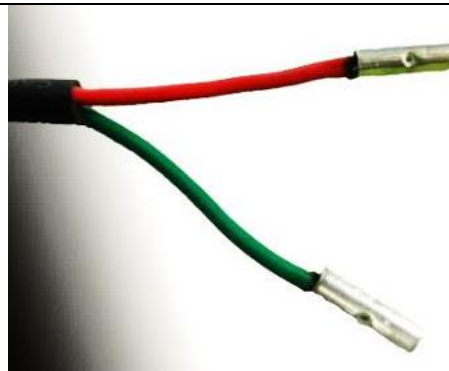

	Clutch side		Harness side
<i>Up to E-5698 / E-2648 Excluded</i>	Blue	→	White
	Brown	→	Orange
<i>From E-5698 / E-2648 And up</i>	Red	→	Orange
	Green	→	Black

7. According to table, splice wires with butt slice #562228. Crimp and solder. Inspect to make sure you have a good crimp and solder.
8. Seal each wire with shrink tube. Seal over the two wires and cable isolation with shrink tube.
9. Attach clutch cable along bracket as shown.

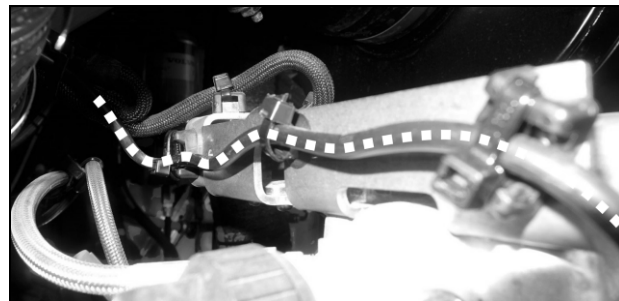

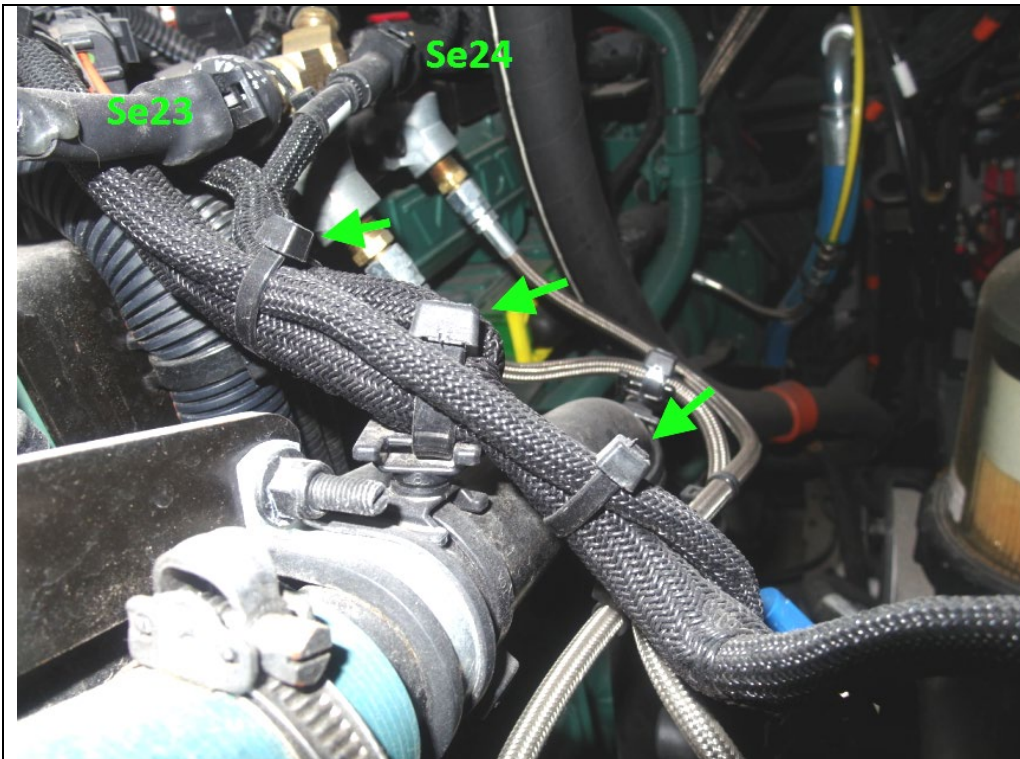

ATTACH THE EXCESS LENGTH OF CABLE ALONG MAIN STRAND OF HARNESS AS SHOWN- NYLON TIES LOCATION SHOWN BY ARROWS

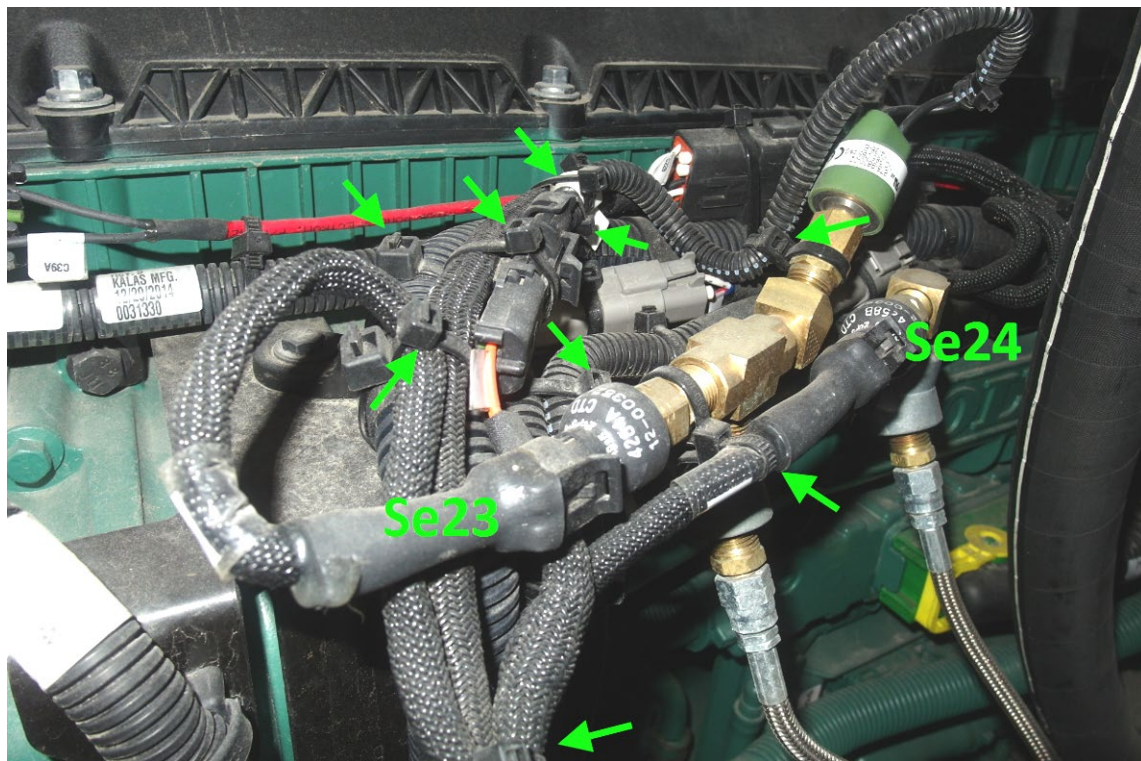

ATTACH THE EXCESS LENGTH OF CABLE ALONG MAIN STRAND OF HARNESS AS SHOWN- NYLON TIES LOCATION SHOWN BY ARROWS

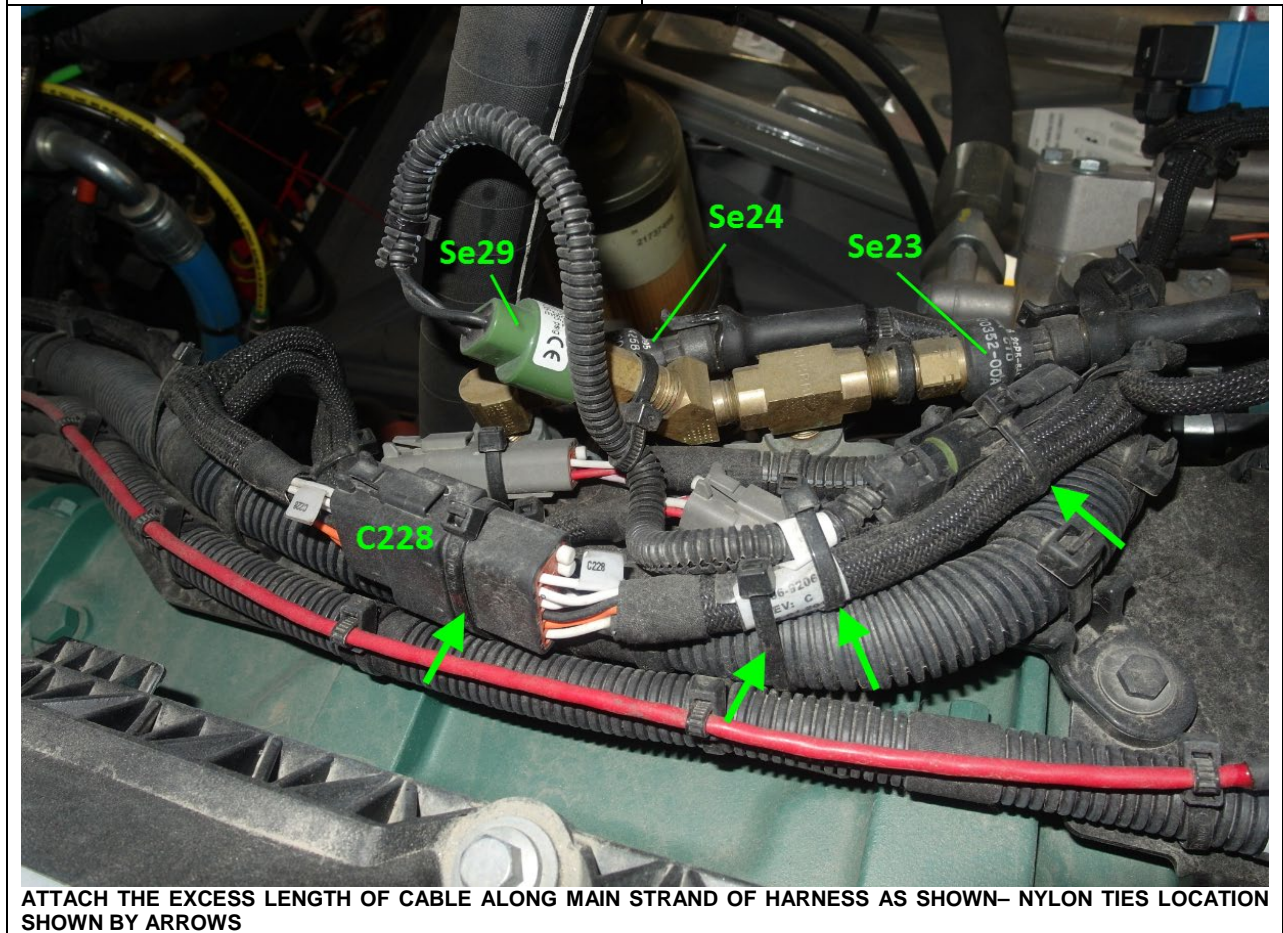
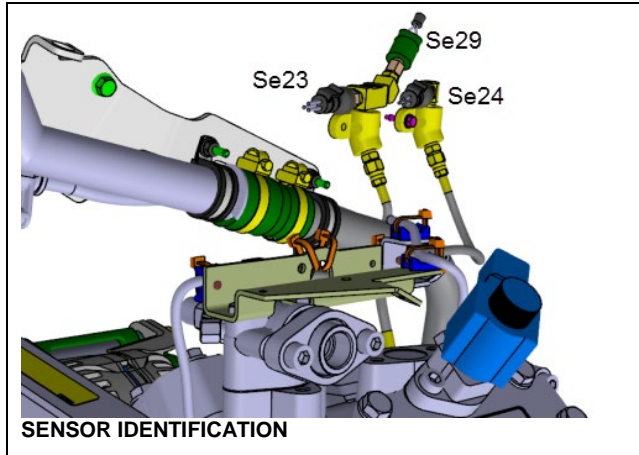

## BEST PRACTICES FOR CABLE SECUREMENT AND ROUTING

(Source: engineering Spec 20.0)

- Prefer larger cable ties over smaller cable ties in your assembly to limit local pinch effect.
- Avoid sharp edges to prevent chaffing and abrasion.
- Always attach over harness loom or corrugated tubes, not on the bare cables themselves.

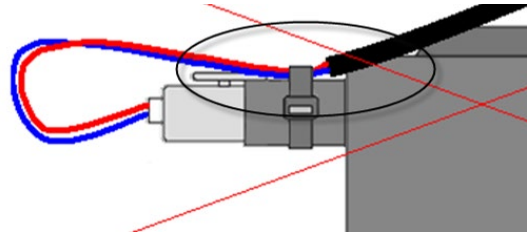

- No over-tightening of cable ties. (Must only prevent harness movement)

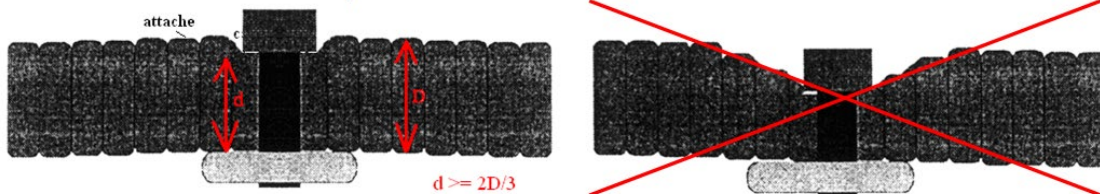

- Perform smart harness routing to prevent water intrusion in the connectors. (nearest low point: below connector)

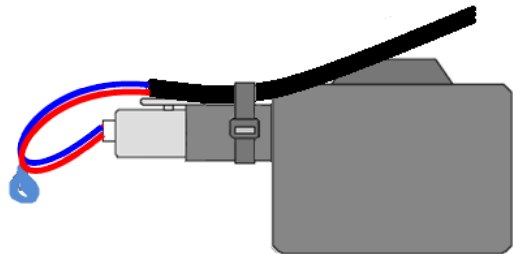

- Also avoid sharp edges of plastic corrugated tubes.

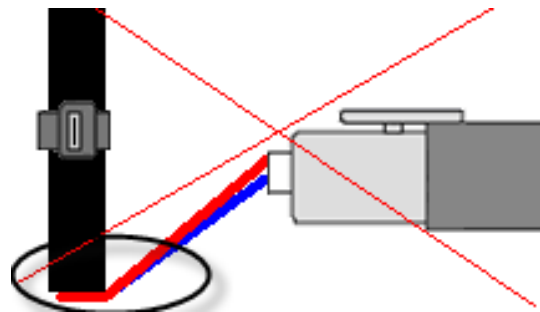

- No pulling or tension on connections.

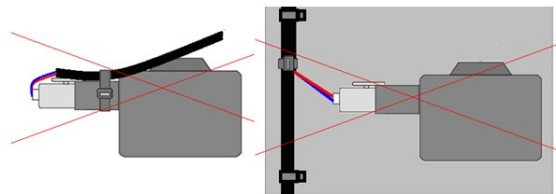

- Avoid sharp radius routing paths. (routing path *inside diameter* = 2 X cable diameter)

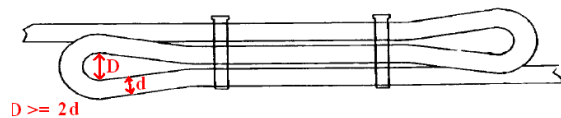

# Assembly instructions for electromagnetic clutches series LA16

P.O.Box 1430  
88672 Markdorf  
Tel. +49 7544 / 9640  
Fax. +49 7544 / 6218  
Internet: <http://www.linnig.com>  
Mail: [webinfo@linnig.com](mailto:webinfo@linnig.com)

**LINNIG®**  
Antriebstechnik



LINNIG-No.: **142.081**  
Revision: E  
Rev.-Date: 22.11.2005

## Assembly instruction:

1. Attach coil according to instruction manual of the compressor manufacturer. Connect cable in a way that avoids contact with hot components (only if coil contains a cable).  $t_{max} = 105^{\circ}\text{C}$
2. Remove circlip and holding-down bolt from clutch-assembly. Slide clutch-assembly onto compressor shaft. Look through the center-hole for a correct position of the compressor shaft key in the rotor-keyway. Rotor should turn freely without touching the coil. Consider the control mark! Insert and tighten holding-down bolt M12 (tightening torque  $Ma = 85 \text{ Nm}$ ,  $Ma = 63 \text{ lbs.ft}$ ). Hold down the rotor with an open-ended spanner or ring spanner WAF41. Insert circlip.
3. Slide pulley over the stud screws (1) and bolt on with nuts M8 DIN 934-8 (2) (only for LA16.3; for other LA16 is pulley integrated part of the clutch).
4. Connect cable respectively connector. The connection is independent of polarity. Allowed operating voltage 21 – 32 VDC.

## Disassembly instruction:

For disassembly grease circlip (do not remove circlip) and turn the holding-down bolt left to loosen. Hold down the rotor with an open-ended spanner or ring spanner WAF41. In this way the clutch will be disconnected from the cone-shaft.

- ! With any other method of disassembly (press or hammer) you risk a damage of the clutch. Clutch damages in this mode are outside any warranty.

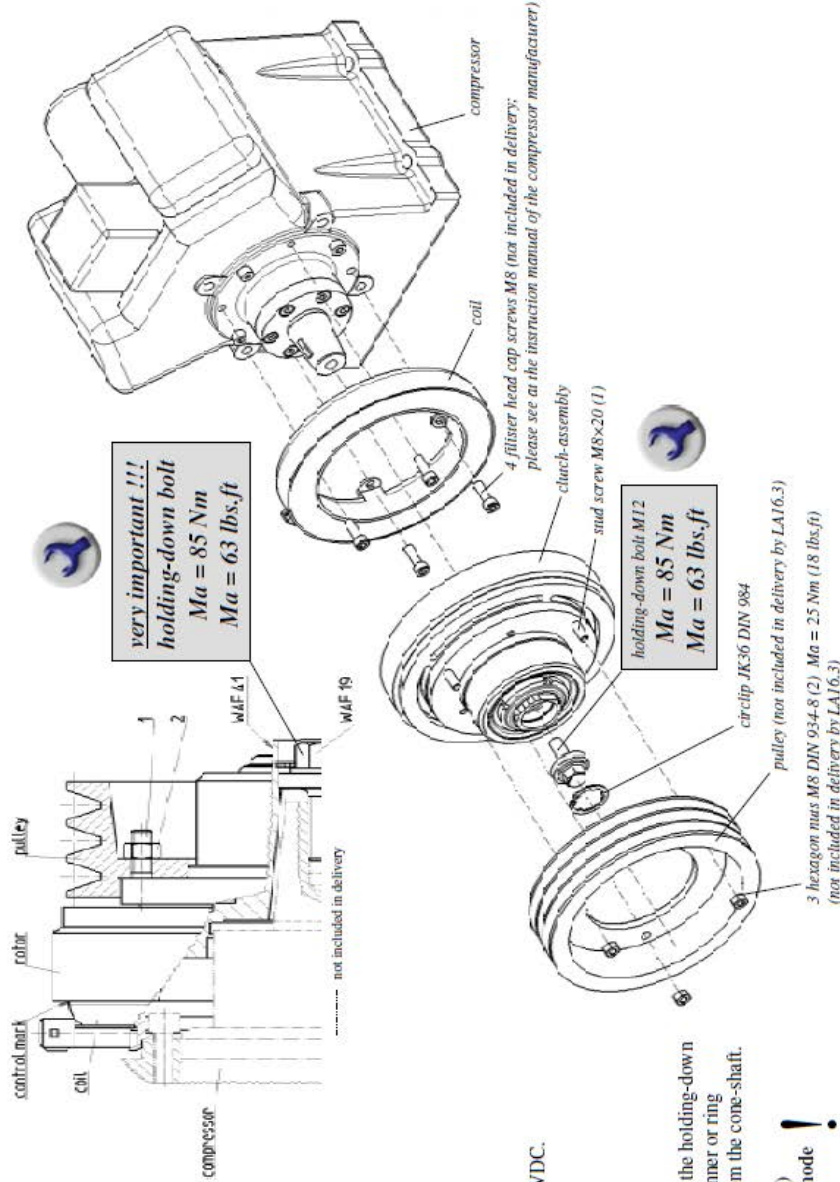

## PARTS / WASTE DISPOSAL

All replaced parts must be returned to Prevost according to the Return Shipping Instructions available on <https://www.prevostcar.com/content/warranty-documents> for full reimbursement. A copy of the warranty claim form must be enclosed with the shipment.

Discard waste according to applicable environmental regulations (Municipal/State[Prov.]/ Federal)

## WARRANTY

This modification is covered by Prevost's normal warranty. We will reimburse you the parts and 2 hours (2.0h) of labor plus an additional half hour (0.5h) applicable only for the replacement of the *Lang clutch coil* by #950533, upon receipt of the replaced part and a warranty claim. Please submit claim via our Online Warranty System, available at [www.prevostcar.com](http://www.prevostcar.com) (under Service \ Warranty section). Use Claim Type: "Bulletin/Recall" and select "Warranty Bulletin WB15-19".

## OTHER

VBC Bulletin	N/A
Fail Code	22.00
Defect Code	09
Syst. Cond	B
Causal Part	950002

Access all our Service Bulletins on <https://secureus5.volvo.com/technicalpublications/en/pub.asp> or scan the QR-Code with your smart phone.  
E-mail us at [technicalpublications\\_prev@volvo.com](mailto:technicalpublications_prev@volvo.com) and type "ADD" in the subject to receive our warranty bulletins by e-mail.

