

Service Update

16167 Missing Cotter Pin on Front Lower Control Arm to Knuckle Ball Joint



Reference Number: N162066530

Release Date: December 2016

Revision: 00

Attention: This service update includes vehicles in dealer inventory and customer vehicles that return to the dealership for any reason. This bulletin will expire at the end of the involved vehicle's New Vehicle Limited Warranty period.

Make	Model	Model Year		RPO	Description
		From	To		
Chevrolet	Equinox	2017	2017		

Involved vehicles are marked "open" on the Investigate Vehicle History screen in GM Global Warranty Management system. This site should always be checked to confirm vehicle involvement prior to beginning any required inspections and/or repairs.

Condition	Certain 2017 model year Chevrolet Equinox vehicles may be missing the cotter pin in either front lower control arm (LCA) ball stud assembly. If the cotter pin is missing, over time, there could be a significant reduction of torque on the front LCA ball stud nut, resulting in a loss of steering control, braking and propulsion at the affected wheel.
Correction	Inspect for the presence of cotter pins. If one or both are missing, the castle nut(s) need to be torqued and cotter pin(s) installed if necessary.

Parts

Quantity	Part Name	Part No.
2	Cotter Pin	11609927

Reminder: Parts may be removed from Retail Inventory Management (RIM). Dealers should review the affected parts to confirm RIM managed status.

Please Note: This part is sold in a package quantity of 10.

Warranty Information

Labor Operation	Description	Labor Time	Trans. Type	Net Item
9102812	Inspect Lower Ball Stud Nut Cotter Pin	0.2	ZFAT	N/A
	Add: Check Torque on Lower Ball Stud Nut and Install Cotter Pin – One Side	0.1		
	Check Torque on Lower Ball Stud Nut and Install Cotter Pin – Both Sides	0.2		

Service Procedure

1. Raise and support the vehicle. Refer to *Lifting and Jacking the Vehicle* in SI.

Service Update

16167 Missing Cotter Pin on Front Lower Control Arm to Knuckle Ball Joint

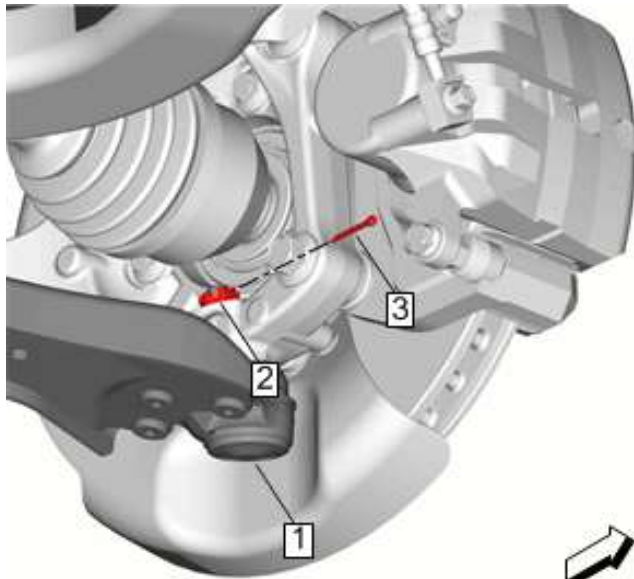

3999404

2. Verify the lower ball stud nut cotter pin (3) is present on both front lower control arm ball studs (1).
 - If the lower ball stud nut cotter pin is present on both sides, proceed to step 8.
 - If either lower ball stud nut cotter pin is NOT present, proceed to step 3.
3. Loosen the front lower control arm ball stud nut (2) until it is level with the top of the front lower control arm ball stud.

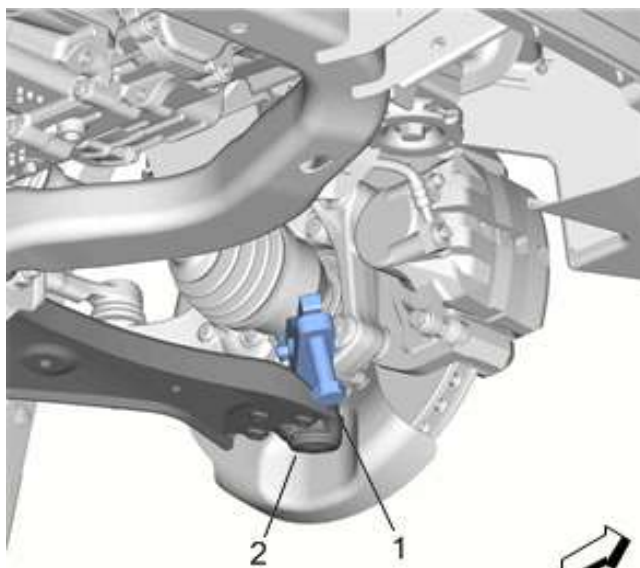

3999405

4. Use the CH-50986 remover (1) to separate the front lower control arm ball stud (2) from the steering knuckle.
5. Tighten the front lower control ball stud nut (2):
 - First pass: 10 Nm (89 lb in)
 - Final pass: (155 – 175 degrees)

Note: Do NOT loosen the front lower control arm ball stud nut when installing the front lower control arm ball stud nut cotter pin. The front lower control arm ball stud nut cotter pin must NOT contact the front wheel speed sensor or the front wheel drive shaft.

6. Install a NEW front lower control arm ball stud nut cotter pin (3).
7. Bend the cotter pin after it has been inserted through the front lower control arm ball stud nut.

Service Update

16167 Missing Cotter Pin on Front Lower Control Arm to Knuckle Ball Joint



8. Lower the vehicle. Refer to *Lifting and Jacking the Vehicle* in SI.

Dealer Responsibility

Whenever a vehicle subject to this service update enters your vehicle inventory, or is in your facility for service in the future, and the vehicle is still covered under the New Vehicle Limited Warranty, you must take the steps necessary to be sure the service update correction has been made before selling or releasing the vehicle.

All new, used, GM Certified Used, courtesy transportation vehicles, dealer shuttle vehicles, etc. in dealers' possession and subject to this bulletin must be held and inspected/repaired per the service procedure of this bulletin before customers take possession of these vehicles. Involved vehicles must be held and not delivered to customers, dealer-traded, released to auction, used for demonstration, or any other purpose.

All GM Certified Used vehicles currently in the dealers' inventory within the Certified Pre-Owned Inventory System (CPOIS) will be de-certified and must be held and remedied per the service procedure in this bulletin. Upon submitting an accepted/paid warranty transaction in the Global Warranty Management (GWM) system, the vehicle can be re-certified for sale within the CPOIS system, or once again be used in the CTP program.



GLOBAL SAFETY FIELD INVESTIGATIONS
DCS4302
URGENT - DISTRIBUTE IMMEDIATELY

Date: December 21, 2016

Subject: 16167 - Service Update
Missing Cotter Pin

Models: 2017 Chevrolet Equinox

To: All General Motors Dealers

General Motors is releasing Service Update 16167 today. The total number of U.S. vehicles involved is approximately 9,000. Please see the attached bulletin for details.

Global Warranty Management (GWM)

The Investigate Vehicle History (IVH) screen in the GWM system will be updated December 22, 2016. A list of involved vehicles in dealer new inventory is attached to this message. Please hold all warranty transactions until the VIN appears in IVH.

END OF MESSAGE
GLOBAL SAFETY FIELD INVESTIGATIONS