

# Service Update

## 16135 One Touch Fold Seat Release



Reference Number: N16207169

Release Date: December 2016  
Revision: 00

**Attention:** This service update includes vehicles in dealer inventory and customer vehicles that return to the dealership for any reason. This bulletin will expire at the end of the involved vehicle's New Vehicle Limited Warranty period.

Make	Model	Model Year		RPO	Description
		From	To		
GMC	Acadia	2017	2017		

Involved vehicles are marked "open" on the Investigate Vehicle History screen in GM Global Warranty Management system. This site should always be checked to confirm vehicle involvement prior to beginning any required inspections and/or repairs.

<b>Condition</b>	Certain 2017 model year GMC Acadia vehicles may have a condition in which the rear cargo area left hand 2nd row seat release handle doesn't release the seat, or requires too much effort to release.
<b>Correction</b>	Dealers are to inspect, and if necessary, adjust the 2nd row seat cable.

### Parts

No parts are required for this procedure.

### Warranty Information

Labor Operation	Description	Labor Time	Trans. Type	Net Item
9102782	Inspect Operation of 2nd Row Seat Release - No Further Action Required	0.2	ZFAT	N/A
	Add: Adjust 2nd Row Seat Cable	0.3		

### Service Procedure

1. Inspect the operation of the 2nd row seat release.
  - If the 2nd row seat releases the seat correctly without extra effort, no further action is required.
  - If the 2nd row seat release handle does not release the seat or requires too much effort, proceed to step 2 and adjust the 2nd row seat release cable.
2. Ensure that the 2nd row seat is in the upright position and both recliners are fully locked.

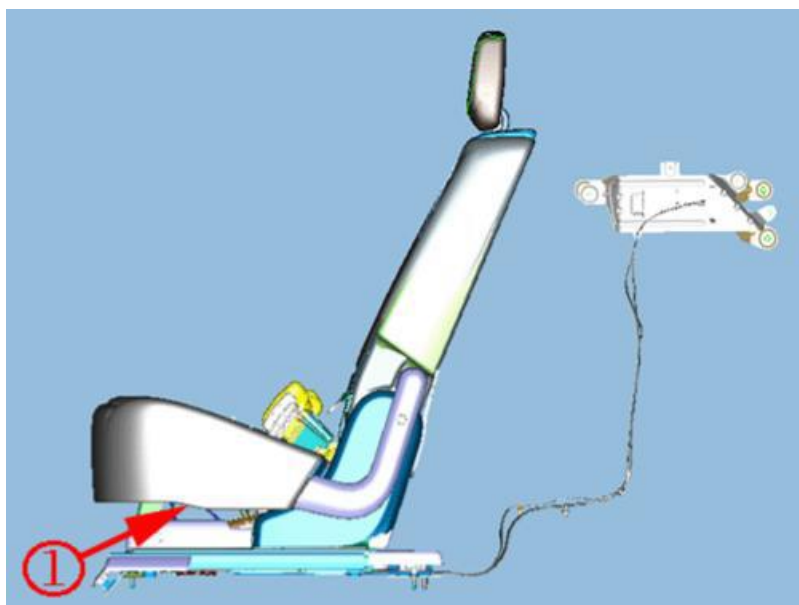

4563488

## Service Update

### 16135 One Touch Fold Seat Release



4640426

3. Look under the seat to locate the One Touch Fold (OTF) cable adjuster # 1 (See picture above) and open the slider on the adjuster body.

**Note:** Do not open the other adjuster (marked with an "X" in the picture above), as it will not help resolve this issue.



4563489

4. To open the adjuster body, pull out and up on the tabs as illustrated above.

**Note:** You may have to remove some cable ties used to secure the adjuster to the bottom of the seat to gain proper access to the adjuster body.

## Service Update

### 16135 One Touch Fold Seat Release

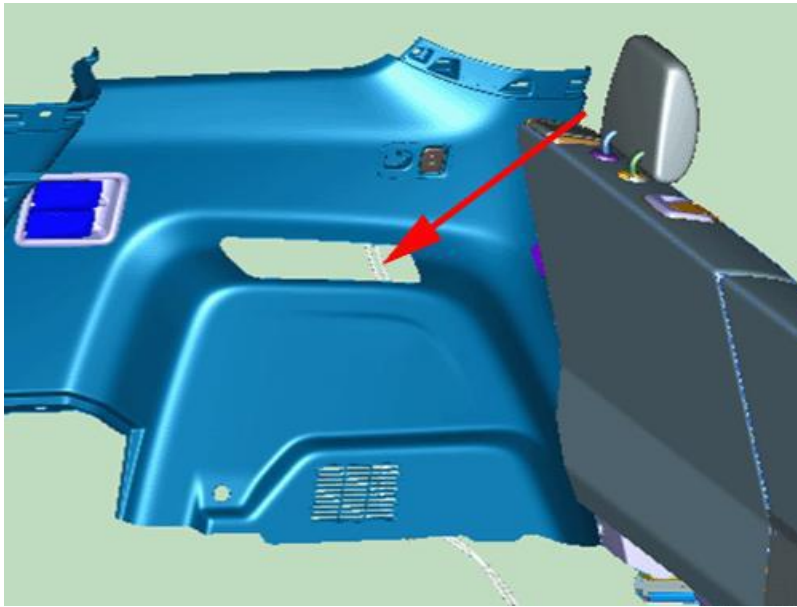

4563491

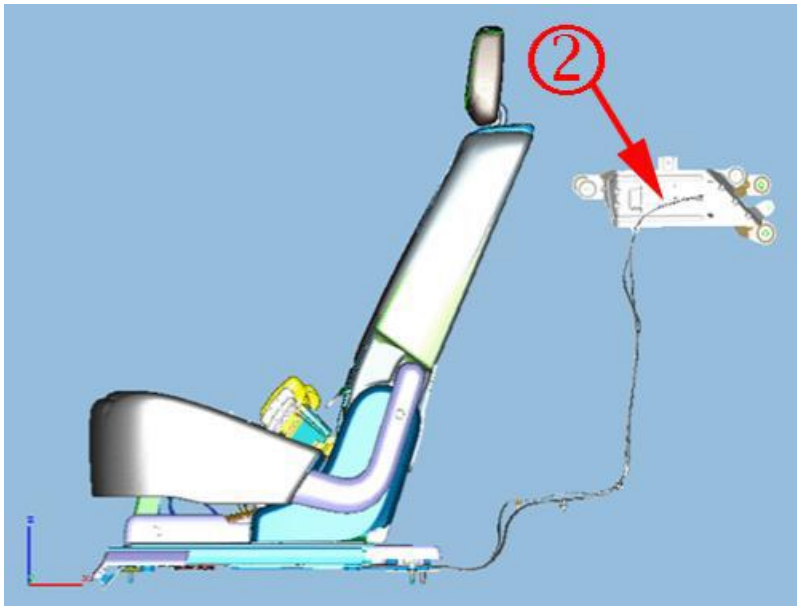

4563490

**Important:** Some early built vehicles may not be equipped with the second adjuster. If there is no adjuster found, proceed to Step 6.

5. Locate the OTF cable adjuster (2) under the 3rd row cup holder in the quarter trim panel. Refer to *Quarter Trim Panel Cup Holder Replacement - Left Side* in SI for the removal of the cup holder. Open the cable adjust slider.

**Important:** Seats must be in upright position and both recliners fully locked prior to closing the cable adjusters. If recliners are not both locked, potential for cable system to hold open one or both recliners exists.

6. Move and adjust the tension on the cable adjuster and close the adjuster under the seat first.
7. If equipped, move and adjust the cable adjuster and close adjuster in quarter trim.
8. Verify release lever function and verify both recliners are locked by returning seat back to the upright position and pushing on each side of seat back to confirm recliners are locked.

**Important:** It may take more than one attempt at adjustments to get the seat to operate as intended. Repeat steps until the concern is corrected.

# Service Update

## 16135 One Touch Fold Seat Release



### Dealer Responsibility

Whenever a vehicle subject to this service update enters your vehicle inventory, or is in your facility for service through December 31, 2017, you must take the steps necessary to be sure the service update correction has been made before selling or releasing the vehicle.

All new, used, GM Certified Used, courtesy transportation vehicles, dealer shuttle vehicles, etc. in dealers' possession and subject to this bulletin must be held and inspected/repaired per the service procedure of this bulletin before customers take possession of these vehicles. Involved vehicles must be held and not delivered to customers, dealer-traded, released to auction, used for demonstration, or any other purpose.

All GM Certified Used vehicles currently in the dealers' inventory within the Certified Pre-Owned Inventory System (CPOIS) will be de-certified and must be held and remedied per the service procedure in this bulletin. Upon submitting an accepted/paid warranty transaction in the Global Warranty Management (GWM) system, the vehicle can be re-certified for sale within the CPOIS system, or once again be used in the CTP program.

---

GM bulletins are intended for use by professional technicians, NOT a "do-it-yourselfer". They are written to inform these technicians of conditions that may occur on some vehicles, or to provide information that could assist in the proper service of a vehicle. Properly trained technicians have the tools, equipment, safety instructions, and know-how to do a job properly and safely. If a condition is described, DO NOT assume that the bulletin applies to your vehicle, or that your vehicle will have that condition. See your dealer for information on whether your vehicle may benefit from the information.



**We Support  
Voluntary Technician  
Certification**

GLOBAL SAFETY FIELD INVESTIGATIONS  
DCS4290  
URGENT - DISTRIBUTE IMMEDIATELY

Date: December 12, 2016  
Subject: 16135 - Service Update  
One Touch Fold Seat Release  
Models: 2017 GMC Acadia  
To: All General Motors Dealers

General Motors is releasing Service Update 16135 today. The total number of U.S. vehicles involved is 27,483. Please see the attached bulletin for details.

**Global Warranty Management (GWM)**

The Investigate Vehicle History (IVH) screen in the GWM system will be updated December 12, 2016. A list of involved vehicles in dealer new inventory is attached to this message. Please hold all warranty transactions until the VIN appears in IVH.

END OF MESSAGE  
GLOBAL SAFETY FIELD INVESTIGATIONS