

Technical Service Bulletin



46 Squeal from front brakes

46 16 32 2043706/1 March 18, 2016.

Model(s)	Year	VIN Range	Vehicle-Specific Equipment
Q5	2013	000001 - 047566	2.0TFSI and 3.0TFSI

Condition

Customer reports hearing a squeal noise from the front brakes in the following conditions:

When:	During first brake application in the morning, with cold brakes
Speed:	Below 20 mph
Temperature:	Below 40°F
Conditions:	High humidity



Tip: For an example of the sound, see the video located at: <https://audi-external.kzoplatform.com/swf/player/319> (Figure 1).



Figure 1. QR code for viewing the video with a QR code reader on phones and tablets. Alternatively, the video can be accessed through computer internet browsers at the link provided in this bulletin.

Technical Background

Not applicable.

Production Solution

Not applicable.

Service

Before proceeding, check the following table to confirm that this bulletin applies.

Model	Model years	Front brakes (Brembo) disc size
Q5 2.0TFSI	2013	320 x 30 mm
Q5 3.0TFSI	2013	345 x 30 mm



Note:

- This TSB only applies to Q5 models listed in the table above.



Tip: Rust/corrosion build-up, grooves, or glazing on the braking surface of the brake disc may cause brake noise and must be considered when replacing brake pads. Brake discs that are worn close to the wear limit or that are at the wear limit may also contribute to brake noise.

1. Replace the front brake pads according to the instructions in Elsa at: *Repair manual >> Chassis Brake System >> 46 Mechanical Components >> Front Brakes >> Brake Pads, Removing and Installing, Brake 1LB and 1LC or Brake Pads, Removing and Installing, Brake 1LE and 1LP.*



Note:

- Some vehicles may have two shims glued to the back of the front brake pads (Figure 2). **Do not** transfer these shims to the new pads.
- New brake pads have an adhesive backing that should be used to properly attach the pads to the caliper.

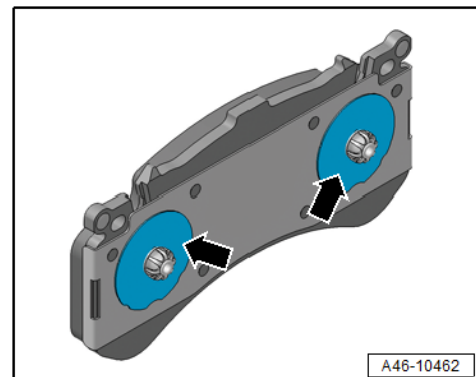

Figure 2. Shims on back of front brake pads.

The following steps must be followed to ensure proper installation of the pads:

- Thoroughly clean and dry each piston (Figure 2, arrows) to ensure that the new pads will properly adhere to the pistons.
- Do not apply any lubricants to the pads or calipers.
- After the pads are installed in the calipers, apply full pedal pressure for at least 10 seconds to ensure proper adhesion of the pads to the pistons.
- In order to allow the glue to set, do not drive the vehicle for 10 minutes after new pads have been installed.

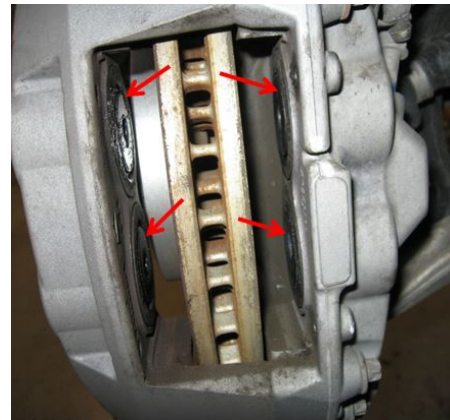

Figure 2. Location of pistons.

2. Embed the brakes:

- A. Use medium pedal pressure to slow the car from approximately 35 mph to 10 mph. Repeat this process ten times.
- B. Next, drive for approximately 5 minutes at maximum allowable speeds, without braking, to allow the brakes to cool down.
- C. Repeat steps A and B if necessary.



Note:

Do not perform ABS stops as a way of embedding the brakes. Brake pads and discs may be permanently damaged if brakes are overheated prior to being properly embedded.

Technical Service Bulletin



Warranty

Claim Type:	110		
Service Number:	4636		
Damage Code:	0010		
Labor Operations:	2 wheels remove+reinstall	4405 2000	20 TU
	Brake pads, front remove+reinstall	4636 2050	50 TU
	Road test prior to service procedure	0121 0002	10 TU
	Road test after service procedure	0121 0004	10 TU
	Technical diagnosis at dealer's discretion (Refer to Section 2.2.1.2 and Audi Warranty Online for DADP allowance details)		
Claim Comment:	As per TSB #2042706/1		

All warranty claims submitted for payment must be in accordance with the *Audi Warranty Policies and Procedures Manual*. Claims are subject to review or audit by Audi Warranty.

Required Parts and Tools

Part Number	Part Description	Quantity
8R0698151L (3.0 TFSI)	1 set of front brake pads	1
8R0698151L (2.0 TFSI)	1 set of front brake pads	1
Check ETKA for applicable part number	Contact (wear sensor)	1

Additional Information

All parts and service references provided in this TSB (2042706/1) are subject to change and/or removal. Always check with your Parts Department and service manuals for the latest information.