



**MAINTENANCE  
INFORMATION**

**MI16-22**

DATE :	APRIL 2016	SECTION :	06 - Electrical
SUBJECT :	MARKER LIGHTS ON IN SLEEP MODE		

***IMPORTANT NOTICE***  
*This modification is recommended by Prevost to increase your vehicle's performance. Note that no reimbursement will be awarded for carrying out this modification.*

**APPLICATION**

Model	VIN
X3-45 coaches X3-45 VIP motorhomes X3-45 VIP commercial use XLII-45 Entertainer Model Year : 2008 - 2012	 <p>With Volvo D13 engine up to 2PCG3349X<u>C</u>C73<u>5274</u> incl.</p>
H3-41, H3-45 coaches H3-45 VIP motorhomes Model Year : 2008 - 2012	<p>With Volvo D13 engine up to 2PCVS3497<u>C</u>C71<u>2058</u> incl.</p>

**DESCRIPTION**

Use this maintenance information procedure to resolve an undesired behaviour on 2008-2012 vehicles. In sleep mode, certain marker lights may remain illuminated.

Refer to Fig 1, to positively identify a vehicle.

## MATERIAL

Parts that may be required depending on vehicle condition:

Part No.	Description	Qty
504637	CABLE TIE 3/16" X 13"	1
560784	DOUBLE WALL SHRINK TUBE	1
562228	BUTT SPLICE	1 ft
562368	TAB TERMINAL 12-8	2
562593	CABLE, YELLOW, 18 GAGE, TXL	1
562771	SOCKET TERMINAL 22-18	10 ft
563588	PIN TERMINAL 20-16	1
563603	SOCKET TERMINAL 20-16	1
680319	ELECTRICAL TAPE	40

## PROCEDURE



### DANGER

Park vehicle safely, apply parking brake, stop engine. Prior to working on the vehicle, set the ignition switch to the OFF position and trip the main circuit breakers equipped with a trip button. On Commuter type vehicles, set the battery master switch (master cut-out) to the OFF position.

**SYMPTOMS**

- VEHICLE IN "SLEEP" MODE.
- SPECIFIC MARKER LIGHTS BELOW REMAIN ILLUMINATED

*Reminder:*  
ON KEY OFF, "SLEEP" MODE ACTIVATES  
-> AFTER 2 HOURS IF VEHICLE IS EQUIPPED WITH KIDDE AFSS  
-> AFTER 15 MINUTES ON VEHICLES WITHOUT AFSS

**CURB SIDE:**  
FRONT MARKER LIGHT, YELLOW  
REAR MARKER LIGHT, RED

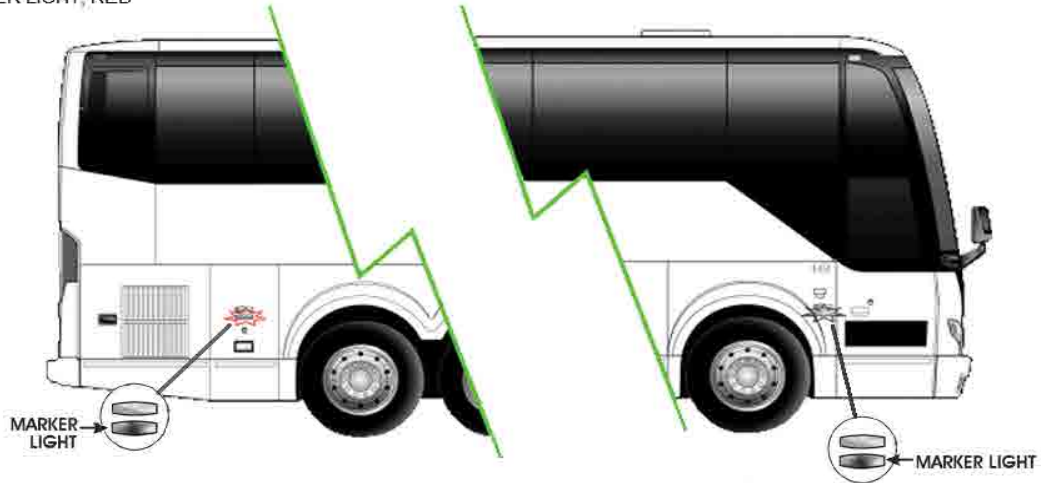

**REAR:**  
LEFT AND RIGHT MARKER LIGHTS, RED



**ROAD SIDE:**  
FRONT MARKER LIGHT, YELLOW  
REAR MARKER LIGHT, RED

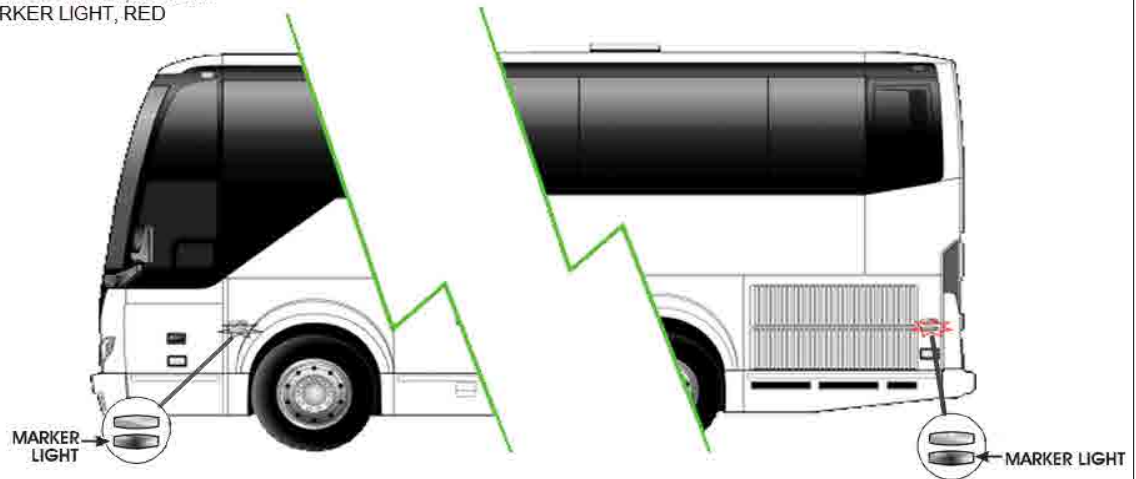

Figure 1 : Illuminated marker lights. (H)

1. If MI12-04 Part B "VECU SUPPLY" has already been performed on the vehicle, remove relay **R22** in VECF.

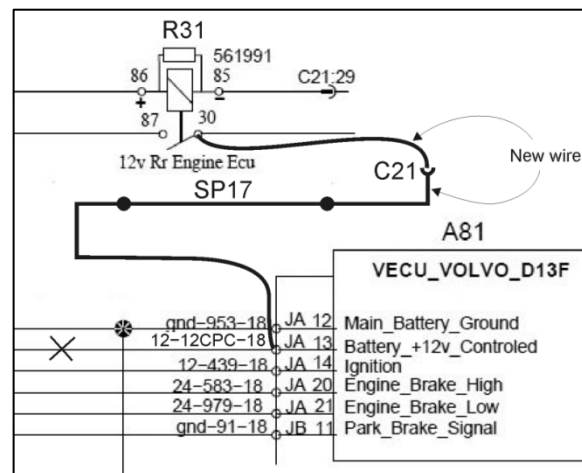

Figure 2 Typical location of R22 in VECF.

2. If MI12-04 part B has not been performed. Proceed with MI12-04C released in April 2016 which includes the removal of R22. This applies to vehicles with EPA 2010 engines onward.
3. On US 2007 vehicles with Volvo engine (Without DEF) perform instructions below according to model.

### H3 SERIES US07 VOLVO D13 ENGINE

1. In rear electrical compartment, locate relay **R31**
2. Cut existing tab terminal at pin 30.
3. Crimp new wire #562593 and existing 12ECU wire on #562368 tab terminal. Replace at pin 30 of R31.
4. Install #563588 pin and #563603 socket terminal to pass new wire through connector C21.
5. (Use extractor tool #682321)
6. Splice new wire end with SP17.  
#562228 butt splice  
#560784 shrink tube
7. Locate SP17 in front electrical and service compartment it is located near C2.
8. Cut wire 12CPC at VECU JA13.
9. Run a new 12CPC wire from spare wire SP17 to JA13. Install #562771 terminal and connect.
10. Once completed, remove R22 from VECF as it is now unused.



### X3SERIES US07 VOLVO D13 ENGINE

1. In rear electrical compartment, locate relay **R34**
2. Remove existing tab terminal at pin 30.
3. Crimp a new wire #562593 and existing 12ECU wire on #562368 tab terminal. Replace at pin 30 of R34.
4. Install #563588 pin and #563603 socket terminal to pass through connector C21. (Use extractor tool #682321 as required)
5. Connect new wire end with SP17.  
#562228 butt splice  
#560784 shrink tube
6. In front electrical and service compartment, cut wire 12VECU at VECU JA13 in front junction box.
7. Run a new 12VECU wire from SP17 to JA13. Install #562771 terminal and connect.
8. Once completed, remove R22 Relay from VECF as it is now unused.

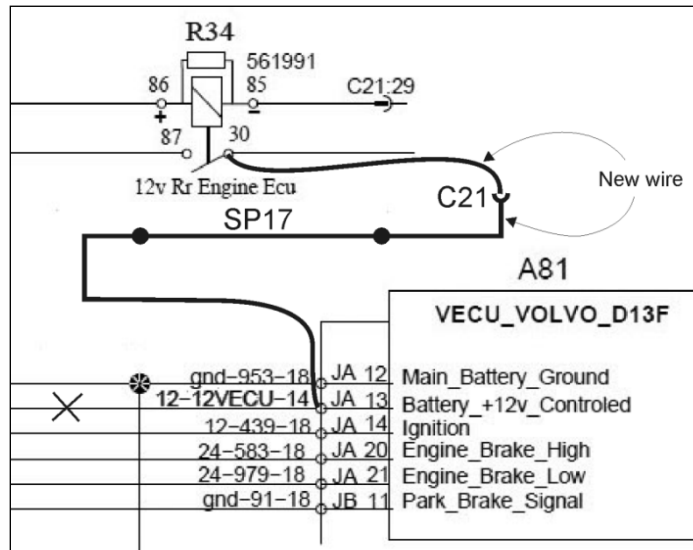

### PARTS / WASTE DISPOSAL

Discard according to applicable environmental regulations (Municipal/State[Prov.]/ Federal)



Access all our Service Bulletins on <https://secureus5.volvoc.com/technicalpublications/en/pub.asp>  
Or scan the QR-Code with your smart phone.

E-mail us at [technicalpublications\\_prev@volvo.com](mailto:technicalpublications_prev@volvo.com) and type "ADD" in the subject to receive our warranty bulletins by e-mail.