

PREVOST

Instruction Sheet

IS-16900A

Driver's Partition and Door Installation





2016 model year H series coaches





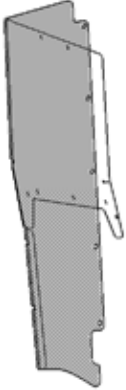

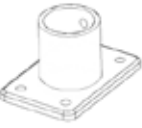





REVISION: A: **THIS INSTRUCTION SHEET SUPERSEDES PREVIOUS VERSION**





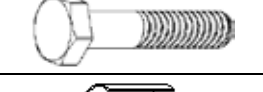



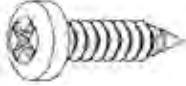

Feb 02, 2016: General revision; Part numbers changed.

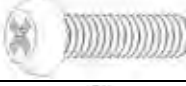

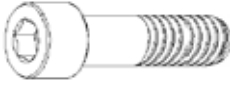
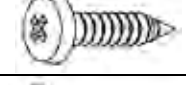
MATERIAL

Kit #200668-1P includes the following parts:

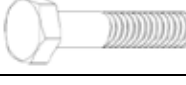
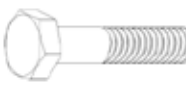
CAD Drawing Item	Part No.	Description	Image	Qty
-	D320002	PARTITION, DRIVER'S INST. DRAWING	-	-
1	320948	PROTECTOR, DRIVER'S, MAKROLON		1
2	320951P	POST ASSEMBLY W/ HINGES		1
3	321273	BRACKET, POST, UPPER		1
4	329586	SUPPORT, PROTECTOR, UPPER		1

5	400064P	DOOR, DRIVER'S PARTITION ASSEMBLY W/ MALE & FEMALE CATCH.		1
6	502643	SCREW MA PAN PH Z050 8/32X1 1/4		2
7	321287	BRACKET, POST, LOWER		1
8	500855	WASHER FL N500 .188X.438X.049		17
9	504399	SNAP CAP WASHER, # 10 SCREW		21
10	500805	WASHER FL N500 7/32X7/8X.062		16
11	321133	PAD		1
12	900251	BUSHING, PARTITION MOUNTING		30
13	504400	CAP TRIM, BLACK 12GA. SCREW		21
14	5001317	SCREW MA PAN PH SS 8-32X1		2
15	500436	SCREW TP OV PH Z050 #10X2		5
16	505539	SPACER 13 X 8 OD X 5.3 ID		16
17	5001315	SCREW CAP HEX SS 1/4-20X1		4
18	329665	TUBE SLEEVE		2
19	500626	SCREW TP OV PH Z050 #8X3/4		2
20	500464	WASHER FN CKF .220X 0.615		2
21	500035	WASHER LOCK SPLIT .317x.586x.078 SS		2

22	5001852	NUT HEX SS NSS M8-1.25		2
23	320995	SUPPORT, PARTITION ASSY		1
24	329671	DECAL, BLACK DRIVERS GATE		1
25	500637	SCREW TP PAN PH Z050 #8X1 1/2		7
26	500764	NUT HEX Z050 8-32		2
27	406192	BRACKET, DOOR LOCK		1
28	500964	WASHER FL Z050 .203X.500X.047		4
29	500387	SCREW MA RND PH Z050 10-24X3/4		2
30	500767	NUT HEX NYRT Z050 10-24		2
31	5001783	SCREW CAP HEXS SS M6-1.0 X 12 FT		4
33	500641	SCREW TP BDG PH Z050 #8X3/4		3
34	5001461	SCREW MA FL PH SS M8-1.25X40 FT		2
35	502634	SCREW SET HEXS CUP M6-1.0X6		3
40	270052	BACKING BRACKET, UPPER POST		1
41	5001697	SCREW CAP HEX SS NSS M6X16		1
42	502860	NUT HEX STOVER N500 M6-1.0		3
43	5001315	SCREW CAP HEX SS 1/4-20X1 SS		1
45	5001681	SCREW CAP HEX SS M6-1 X 60 LG. PT		2

46	320952	BACKING PLATE, POST BASE		1
-	400177	SUPPORT, MIRROR		1
-	509805	SCREW, TAPPING PAN PH #10x1/2 BLACK		8
	IS-16900	Instruction Sheet		1

Other parts that may be required:

Part No.	Description	Qty
680038	LOCTITE 243, 50 ML	

NOTE

Material can be obtained through regular channels.

PROCEDURE



DANGER

Park vehicle safely, apply parking brake, stop engine. Prior to working on the vehicle, set the ignition switch to the OFF position and trip the main circuit breakers equipped with a trip button. On Commuter type vehicles, set the battery master switch (master cut-out) to the OFF position.

NOTE

As a general guideline, **use Loctite 243 on all threads** except on hardware having *Stover type nuts*.

NOTE

Prior to starting work, protect the LCD monitor, vehicle flooring around the aisle and steps as well as the driver's seat. Do not peel protecting paper off until the end of the procedure.

Procedure overview.

A reference CAD drawing is available at the end of this document.

We will start by removing the fore roof panel to remove an insulation section and get access to the roof structure. We will also move the driver's seat aside.

Then we will proceed to the installation of the upper and lower post structural reinforcements.

Once this is completed, we will install the post assembly and transparent protector panel, rear of the driver's seat.

Next, we will install the door on the post assembly and the catch curb side of the aisle.

Finally, the center mirror will be moved higher with a new bracket.



FIGURE 1 : COMPLETE INSTALLATION OVERVIEW

1. Remove trimming, parcel rack doors and gas springs to allow removal of carpet ceiling.
2. Remove the first section of carpet ceiling.



FIGURE 2

- Cut a section of the foam insulation road side, next to the monitor.

Remove about 16in wide to create working space for drilling.



FIGURE 3

- Install the upper post support #270052. Refer to Figure 4 for bracket orientation.

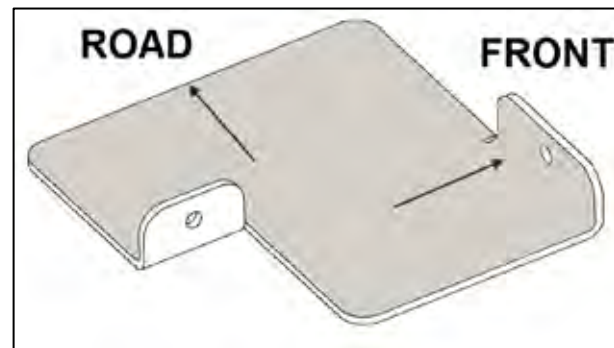

FIGURE 4

- Install bracket #270052 as shown in fig. 5. Clamp the bracket on the longitudinal roof channel.

- Adjust bracket to have bottom face flush (tangent) with the transversal roof curve. We want to avoid any warping of the carpet ceiling section once post support is installed.

- On the front transverse member, drill 7/32" and tap 1/4-20 using a thread cutting screw or tapping tool. Assemble with:

#5001315 Hex cap screw 1/4-20 x 1

- On the longitudinal member, drill 7/32". Assemble with:

#5001697 Hex Cap screw, M6 X 16

#502860 Stover nut, M6

- Place a masking tape on the neighboring roof section and outline bracket location with a marker pen.

- Remove driver seat base mounting bolts and move the driver's seat road side.

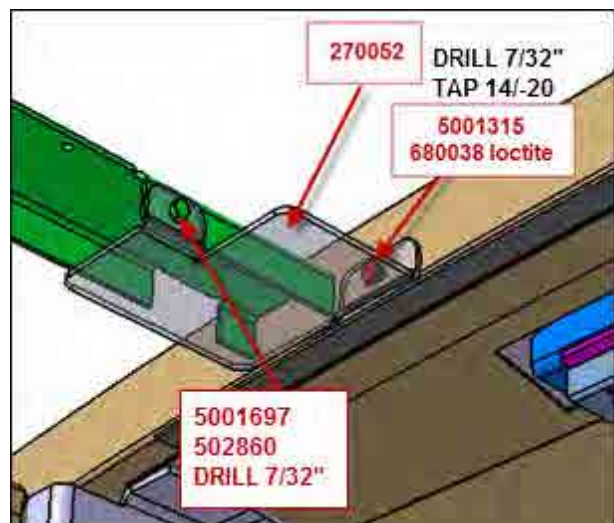

FIGURE 5

11. Remove the aisle step road side fiber cap located alongside the driver's seat.

Enlarge the existing trimming as shown in fig. 6



FIGURE 6

Step preparation.

12. Drill 1/4" in tube using bracket #320952 as a drilling template.

Assemble with 2x #5001681 M6 x 60mm lg screw and 2x #502860 M6 Stover nut.

Tighten to

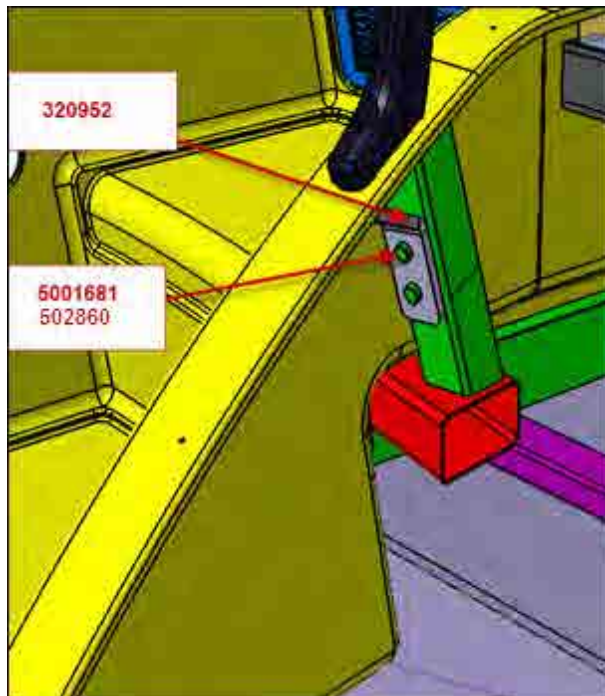

FIGURE 7



FIGURE 8

Protector preparation

13. Install a band of black decal #329671 in the inside corner of the transparent protector.

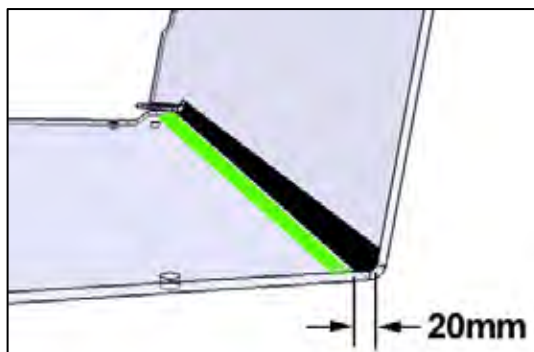

FIGURE 9

14. Pre-install rubber bushings **#900251** (2 / hole) in each hole on the protector.

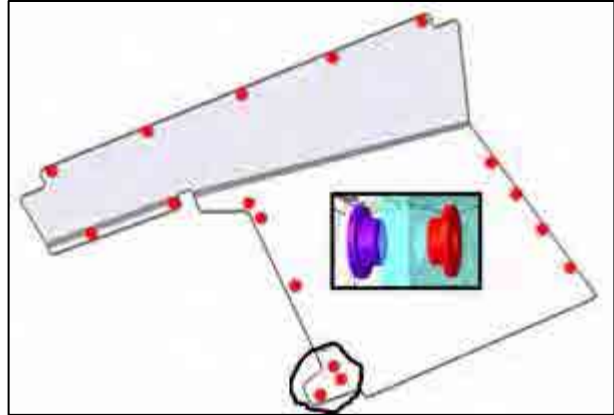

FIGURE 10

15. Place support **#320995** on modesty panel..

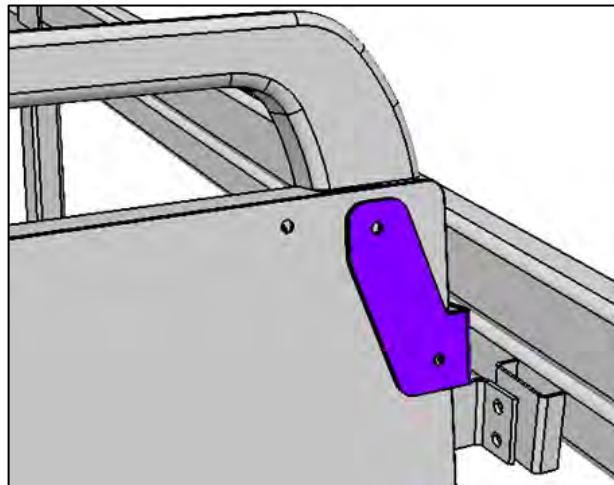

FIGURE 11

Protector installation: two team members are required.

16. Move protector in place and use a center punch to locate holes.
17. Install with the following hardware

- #505539** Bushing
- #500805** Flat washer, 7/8" OD
- #504399** Snap cap washer
- #500855** Flat washer, 7/16" OD
- #500637** #8 Pan head screw 1 1/2" lg
- #504400** Cap

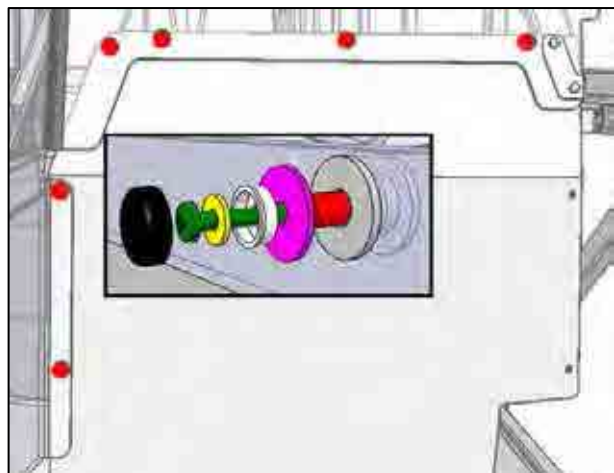

FIGURE 12

18. Use following hardware on the support

#500805 Flat washer, 7/8" OD

#504399 Snap cap washer

#500855 Flat washer, 7/16" OD

#500637 #8 Pan head screw 1 1/2" lg

#504400 Cap, black

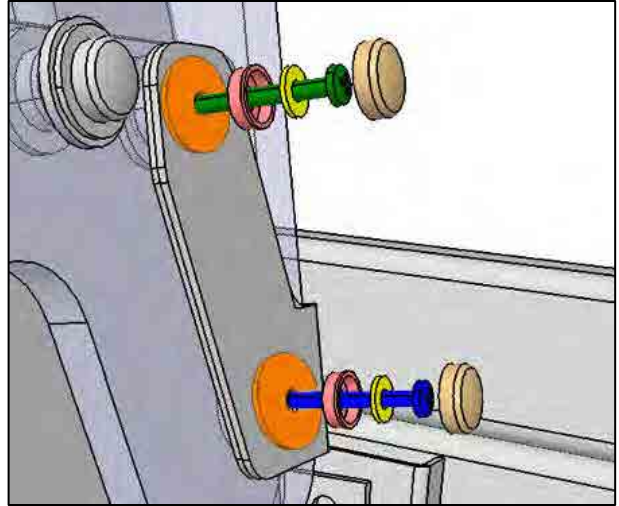

FIGURE 13

19. Insert sleeve **#329665** inside lower post bracket **#321287** and upper post bracket **#321273**.

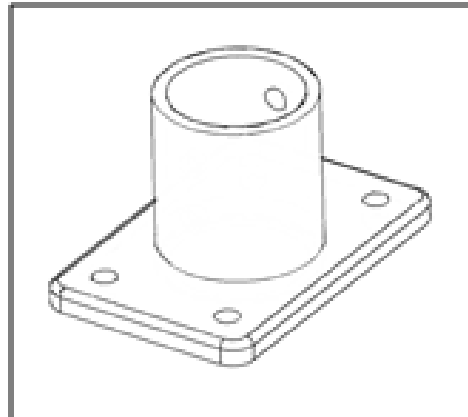
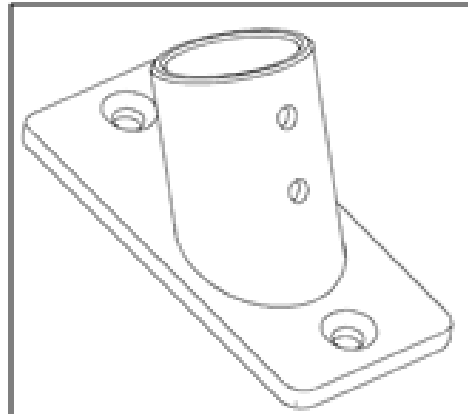
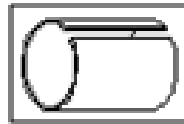

FIGURE 14

20. Slide post assembly **#320951P** in the bases.

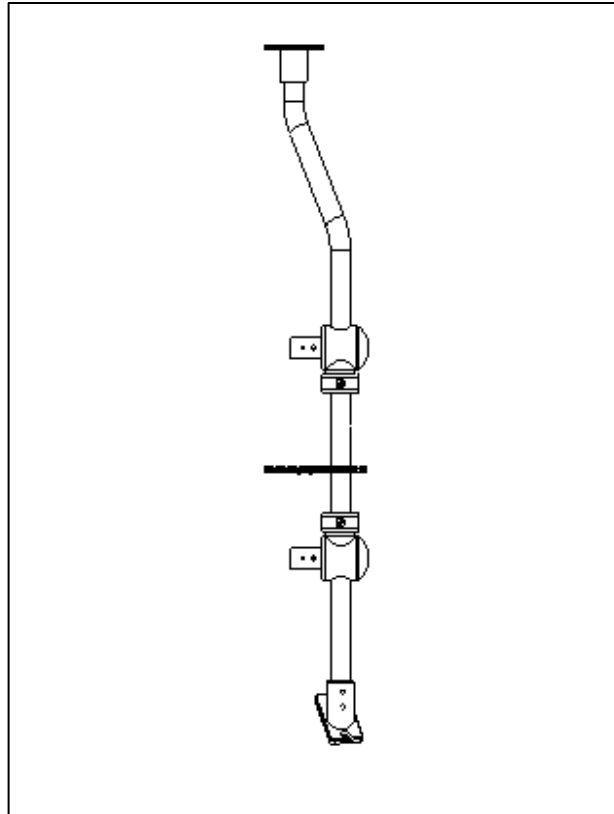

FIGURE 15

21. Secure the transparent protector to the post.

Use the following hardware:

#505539 (5X) Bushing

#500805 (5X) Flat washer, 7/8" OD

#504399 (5X) Snap cap washer

#500855 (5X) Flat washer, 7/16" OD

#500436 (5X) #10 Oval head Screw 2" lg

#504400 (5X) Cap, black

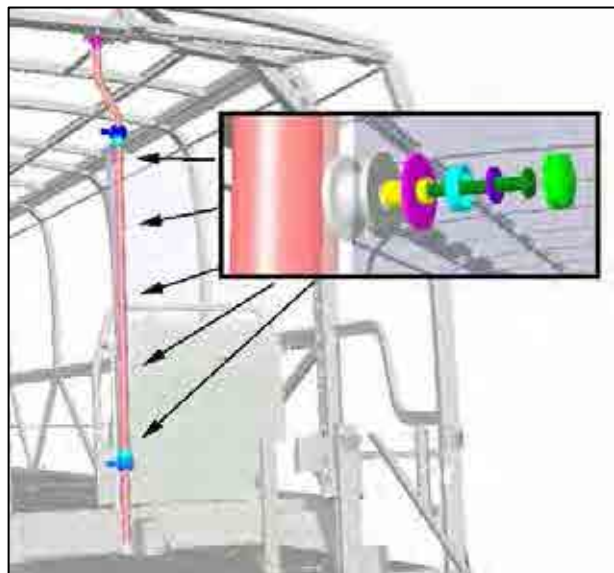

FIGURE 16

22. Locate the lower section of the post.
23. Drill 8mm holes using post base as template.
24. Place rubber pad #321133 under post.
25. Install with the following hardware:
 - #5001461 Screw, flat head M8 x 40mm lg
 - #500035 Washer lock split 0.586 in OD
 - #5001852 Nut, M8



FIGURE 17

- Two team members are required.
26. Reinstall carpet roof section.

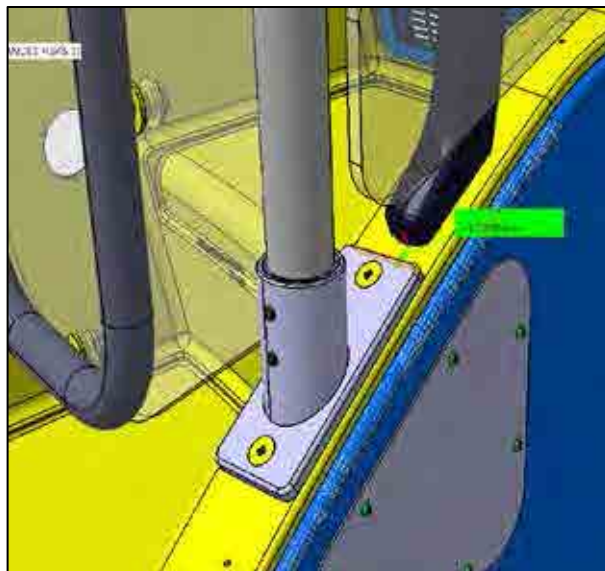

FIGURE 18



FIGURE 19

27. Locate upper post. Use a level.
28. Also allow clearance for the opening of the parcel rack door.
29. Drill 7/32" using post base as a template. **Place a drill stop at 40mm (1 1/2") to avoid drilling through roof.**
30. Tap 1/4-20.
31. Use loctite 243 #680038
32. Install #5001315 (4x) 1/4-20 x 1 SS screws.

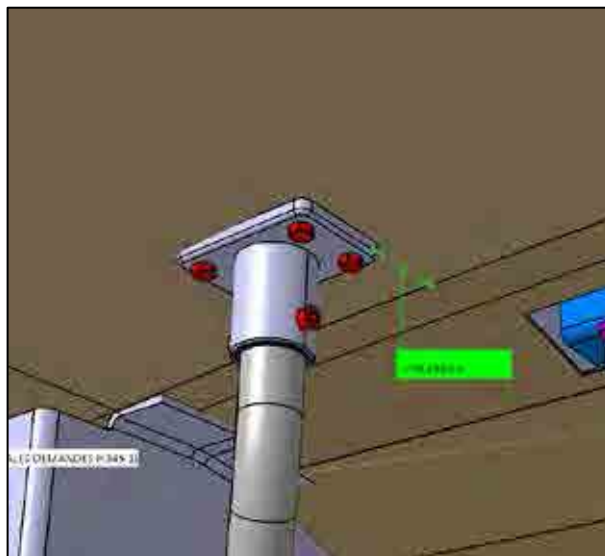

FIGURE 20

33. Install **#329586** upper protector support
34. Drill 1/8"
35. Install with the following hardware:
 - #500464** (2X) Countersink washer
 - #500626** (2X) Oval head screw #8 x 3/4

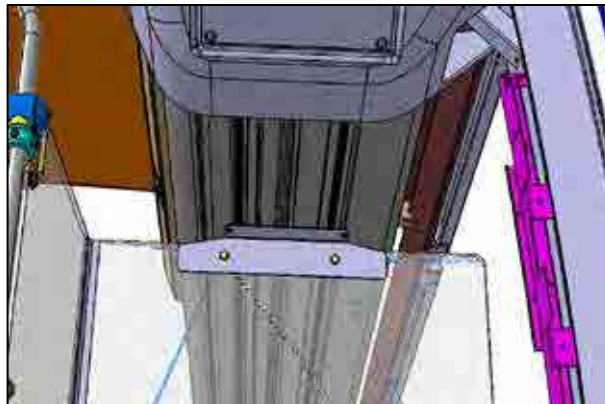

FIGURE 21

36. Secure protector to panel with the following hardware:
 - #900251** (4X) Rubber bushing
 - #504400** (4X) Cap, black
 - #500805** (2X) Flat washer, 7/8" OD
 - #504399** (4X) Snap cap washer
 - #505539** (2X) Bushing
 - #5001317** (2X) Pan head screw 8-32 x 1
 - #500764** (2X) Hex nut 8-32

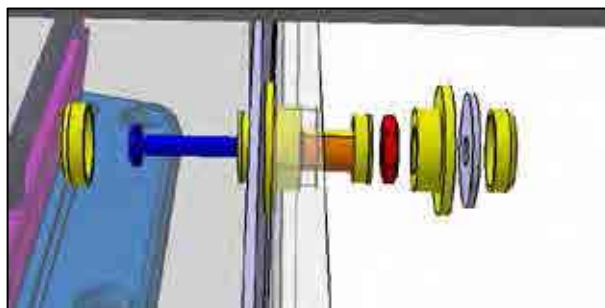

FIGURE 22

37. Install door on the post hinges. Confirm proper alignment of holes, drill if required. Use following hardware:
 - #900251** (2X) Rubber bushing
 - #505539** (2X) Bushing
 - #500805** (2X) Flat washer, 7/8" OD
 - #504399** (2X) Snap cap washer
 - #500855** (2X) Flat washer, 7/16" OD
 - #680038** Loctite 243
 - #502643** (2X) Pan head screw 8-32 x 1 1/4.
 - #504400** (2X) Cap, black
 - #680038** Loctite
 - #5001783**(2X) SHCS M6 x 12mm

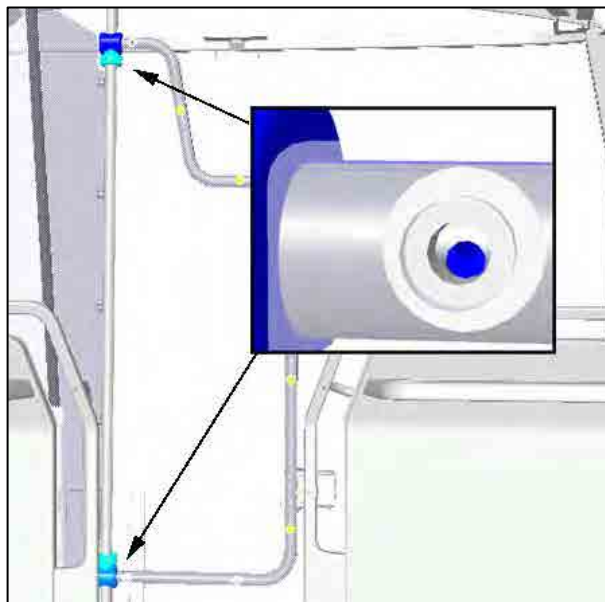

FIGURE 23

****Lower hinge only****

38. Unscrew the three set screws.
39. Re-install set screws with Loctite 243.

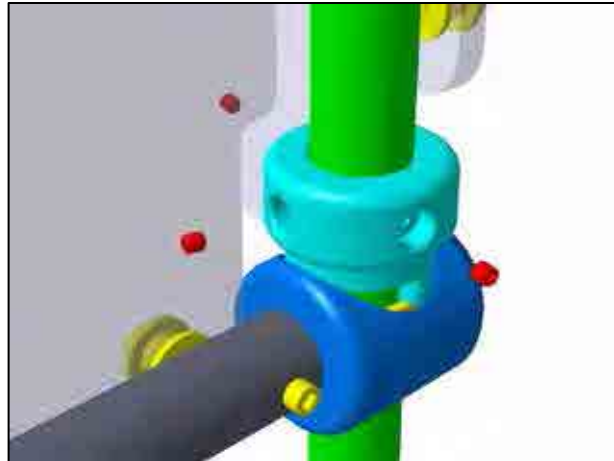

FIGURE 24

40. Upper post securement. Use the following hardware:

- #5001783 (2X) SHCS M6 x 12mm**
- #680038 Loctite**
- #502634 (1X) Set screw M6 x 6mm**

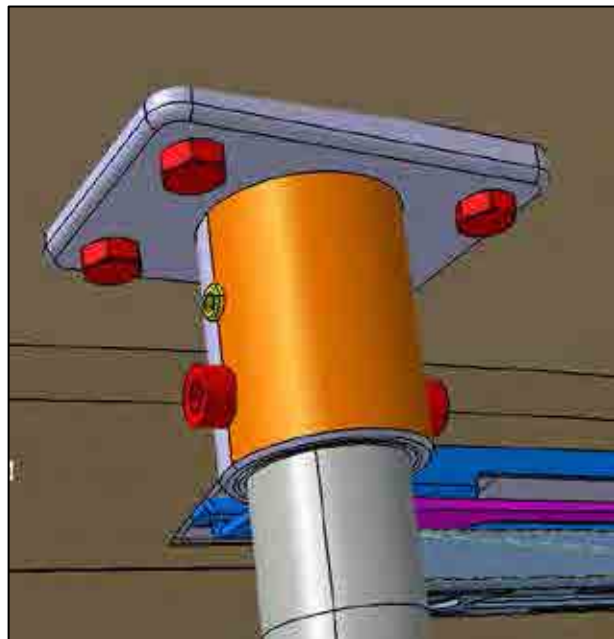
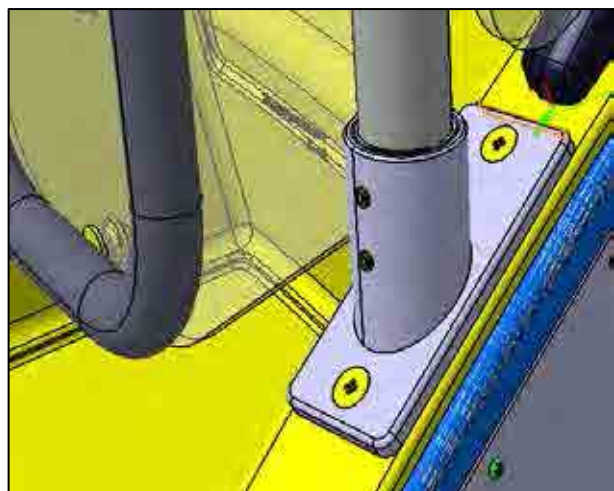

FIGURE 25

41. Lower post securement. Use the following hardware

- #680038 Loctite**
- #502634 (2X) Set screw M6 x 6mm**



42. Door should not turn open by its own upon a sudden stop. Adjust pressure balls if required.

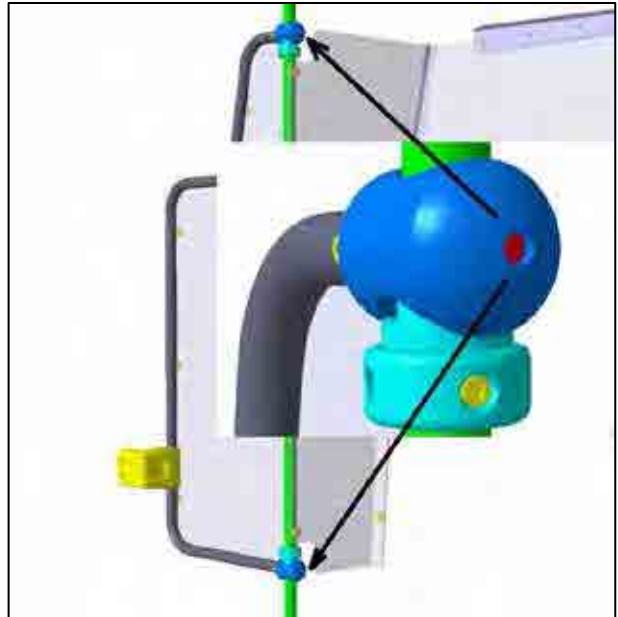

FIGURE 26

43. Catch assembly. Do not tighten yet!

#406192 (1X) Catch support

Female catch (comes with door assembly)

#500964 (4X) Washer 0.500 OD

#500767 (2X) Nut 10-24

#500387 (2X) Screw, 10-24 x 3/4

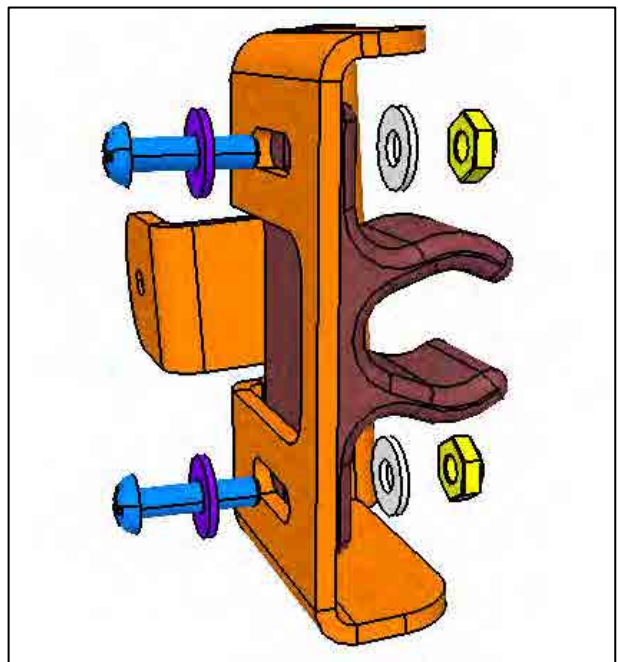

FIGURE 27

- 44. Close the door and align female catch.
- 45. Drill 1/8"
- 46. Assemble on handrail with following hardware:
 - #504399 (3X) Snap cap washer
 - #500855 (3X) Flat washer, 7/16" OD
 - #500641 (3X) Screw, #8 x 3/4
 - #504400 (3X) Cap, black

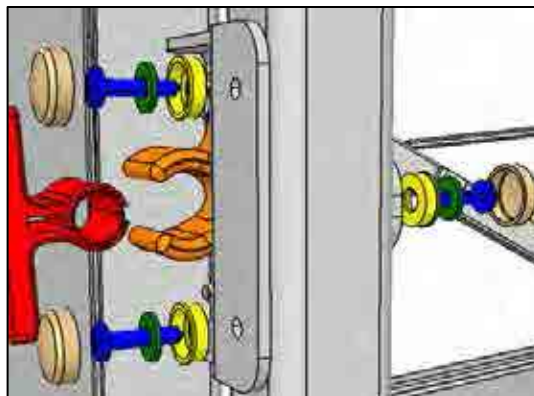

FIGURE 28

- 47. Close door.
- 48. Tighten the female catch assembly.

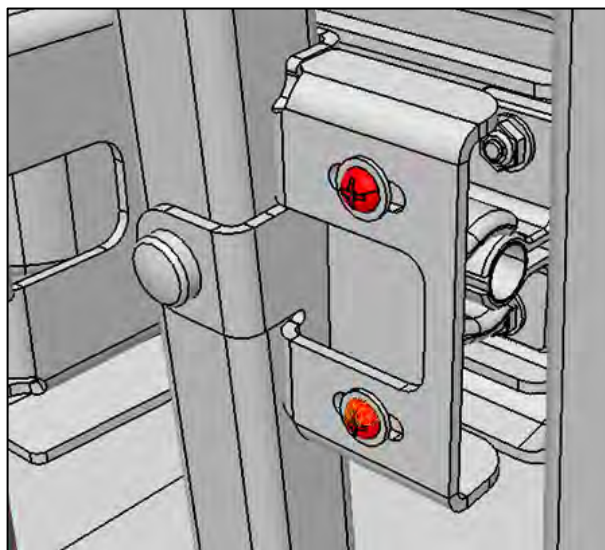

FIGURE 29

- 49. Door should be open with a force of 50 to 55 pounds.
- 50. Turn adjusting screw accordingly.



FIGURE 30

Move center mirror position further up.

51. Dismount and discard original bracket.

52. Fill former holes with:

#509805 (4X) Tapping screw #10 x 1/2 lg

53. Replace by new bracket **#400177**.

54. Drill 1/8" holes using bracket as template.
Install with:

#509805 (4X) Tapping screw #10 x 1/2 lg

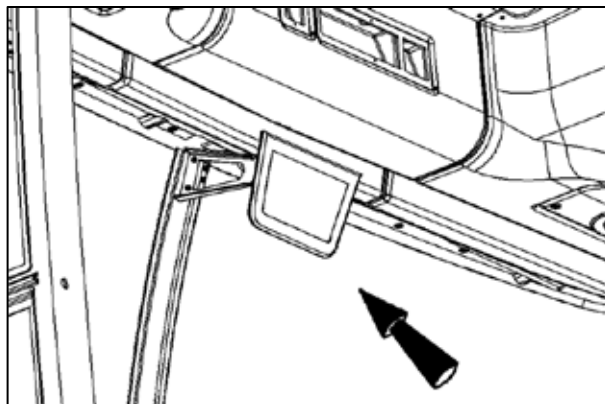

FIGURE 31

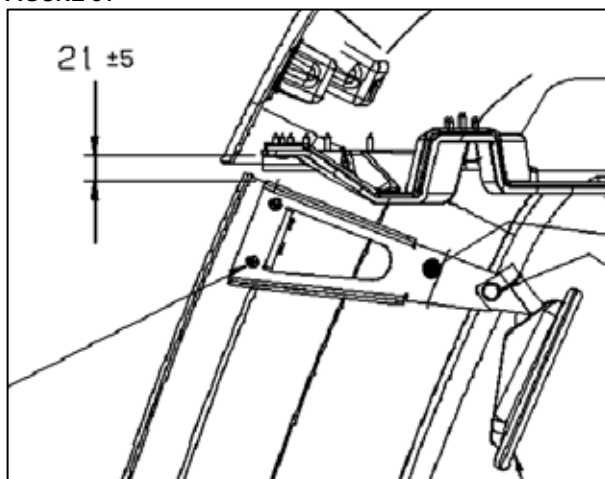

FIGURE 32

55. Move the infrared sensor in this location, under the new mirror bracket.



FIGURE 33

56. Peel protecting paper off the panel and door.

PARTS / WASTE DISPOSAL

Discard waste according to applicable environmental regulations (Municipal/State[Prov.]/ Federal)

