

SERVICE MANUAL INFORMATION

Group:	SERVICE MANUAL UPDATE
Bulletin No:	SB-16-001
Issue Date:	1-8-2016

Subject: CORRECTION OF WORKSHOP MANUAL FOR HINO COE Correction of Clearance Between the Front Leaf Spring Bracket Pin and Bushing

RELEVANT MODEL: 13MY-17MY Hino 155, 195, 155h, 195h

The following is to inform you of the above caption. This service data should be attached to the relevant pages of the workshop manuals for maintenance and to use for servicing.

OVERVIEW:

Correction of clearance between the front leaf spring bracket pin and leaf spring bushing.

RELEVANT MANUALS:

MODEL	MANUAL No.	CHAPTER
2013 MY	S1-LXJE01C	STANDARD VALUE, SUSPENSION
2014 MY	S1-LXJE03A	STANDARD VALUE, SUSPENSION
2015 MY	S1-LXJE05A	STANDARD VALUE, SUSPENSION
2016 MY	S1-LXJE08A	STANDARD VALUE, SUSPENSION
2017 MY	S1-LXJE10A	STANDARD VALUE, SUSPENSION



A Toyota Group Company

SERVICE MANUAL INFORMATION

Group:	SERVICE MANUAL UPDATE
Bulletin No:	SB-16-001
Issue Date:	1-8-2016

11-2

SUSPENSION/STANDARD VALUE

STANDARD VALUE

FRONT SUSPENSION

SHOCK ABSORBER

EN01E11ZZ2010701002001

TIGHTENING TORQUE

Unit: N·m {kgf·cm, lbf·ft}

Tightening part	Tightening torque	Remarks
Shock absorber mounting lock nut	Tighten until excessive protrusion of the threaded portion become 2-3 pitch.	—
Shock absorber mounting nut (lower side)	76 {775, 56}	—
Front wheel mounting nuts	440-590 {4,500-6,000, 325-435}	—

LEAF SPRING

EN01E11ZZ2010701002002

STANDARD VALUE, LIMIT AND ACTION

Unit: mm {in.}

Inspection item	Standard value	Usable limit	Action
Diameter of the spring bracket front pin	24.96-24.98 {0.983-0.983}	—	Replace
Inner diameter of the spring bimetal formed bushing - Diameter of the spring bracket front pin	0.020-0.125 {0.0008-0.0049}	0.5 {0.020}	Replace

CHANGE

TIGHTENING TORQUE

Unit: N·m {kgf·cm, lbf·ft}

Tightening part	Tightening torque	Remarks
U-bolt mounting nut	195 {1,988, 144}	—
Spring center nut	44 {449, 32}	—
Shock absorber mounting nut	76 {775, 56}	—
Spring assembly mounting nut	78.5 {800, 58}	—
Spring assembly mounting bolts and nuts	52 {530, 38}	—



A Toyota Group Company

SERVICE MANUAL INFORMATION

Group:	SERVICE MANUAL UPDATE
Bulletin No:	SB-16-001
Issue Date:	1-8-2016

11-4

SUSPENSION/STANDARD VALUE

REAR SUSPENSION

SHOCK ABSORBER

EN01E11ZZZ010701003001

TIGHTENING TORQUE

Unit: N·m {kgf·cm, lbf·ft}

Tightening part	Tightening torque	Remarks
Shock absorber mounting bolts	68 {693, 50}	—

LEAF SPRING

EN01E11ZZZ010701003002

STANDARD VALUE, LIMIT AND ACTION

Unit: mm {in.}

Inspection item	Standard value	Usable limit	Action
Diameter of the spring bracket front pin	24.96-24.98 {0.983-0.983}	—	Replace
Inner diameter of the spring bimetal formed bushing - Diameter of the spring bracket front pin	0.020-0.125 {0.0008-0.0049}	0.5 {0.020}	Replace

CHANGE

TIGHTENING TORQUE

Unit: N·m {kgf·cm, lbf·ft}

Tightening part	Tightening torque	Remarks
Leaf spring, silencer and spacer mounting center nuts	44 {449, 32}	—
U-bolt mounting nut	265 {2,702, 195}	—
Rear wheel mounting nuts	440-590 {4,500-6,000, 325-435}	—
Leaf spring shackle No.2 mounting bolt	52 {530, 38}	—
Leaf spring assembly mounting bolts and nuts	52 {530, 38}	—



A Toyota Group Company

Group:	SERVICE MANUAL UPDATE
Bulletin No:	SB-16-001
Issue Date:	1-8-2016

11-16

SUSPENSION/FRONT SUSPENSION

INSPECTING THE LEAF SPRING

1. INSPECTING THE LEAF SPRING

- (1) Inspect the leaf spring for worn, crack and fatigue. If abnormalities are found, replace the leaf spring.

CAUTION

If leaf springs need to be replaced, always use genuine parts. Failing to do so will result in not only shortening of the leaf spring life but also serious accidents.

2. INSPECTING THE LEAF SPRING BRACKET PIN

- (1) Using the micrometer, measure the diameter of the leaf spring bracket pin.
- (2) When it exceeds the permissible limit, replace them to a new one.

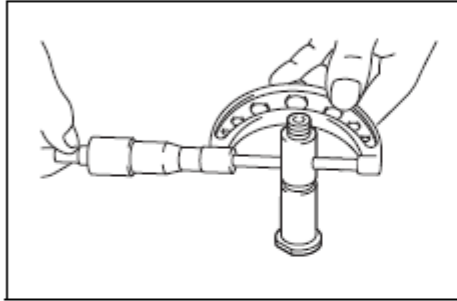

SH1511ZZZ0500021

Standard value (mm {in.})	24.96-24.98 {0.9832-0.9833}
---------------------------	--------------------------------

3. INSPECTING THE SPRING BIMETAL FORMED BUSHING

- (1) Using the cylinder head, measure the internal diameter of the spring bimetal formed bushing.
- (2) To calculate the clearance, subtract the leaf spring bracket pin diameter from the spring bimetal formed bushing diameter.
- (3) If the measured value exceeds the standard value, replace the defective components (leaf spring bracket pin or spring bimetal formed bushing).

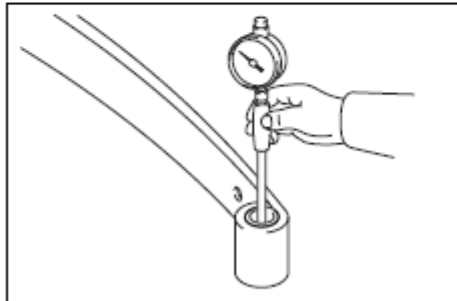

SH1511ZZZ0500022

Standard value (mm {in.})	Usable limit (mm {in.})
0.020-0.125 {0.0008-0.0049}	0.5 {0.020}

CHANGE



A Toyota Group Company

Group:	SERVICE MANUAL UPDATE
Bulletin No:	SB-16-001
Issue Date:	1-8-2016

INSPECTING THE LEAF SPRING

1. INSPECTING THE LEAF SPRING

- (1) Inspect the leaf spring for worn, crack and fatigue.

⚠ CAUTION

If abnormalities are found, replace with a new part.

- (2) Inspect the U-bolts and caster shim for worn, crack and fatigue.

⚠ CAUTION

If abnormalities are found, replace with a new part.

- (3) Inspect the spring shackle for worn, crack and fatigue.

⚠ CAUTION

If abnormalities are found, replace with a new part.

2. INSPECTING THE LEAF SPRING BRACKET PIN

- (1) Use the micrometer to measure the leaf spring bracket pin diameter. If a measurement reading exceeds the standard value, replace with a new one.

Standard value (mm (in.))	24.96-24.98 {0.983-0.983}
---------------------------	---------------------------

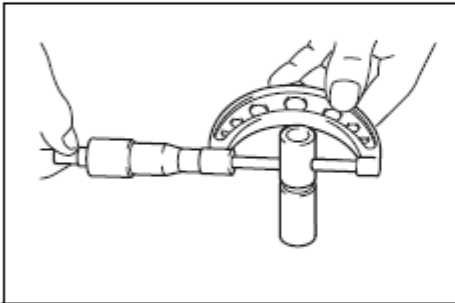

SHTS11ZZZ0600023

3. INSPECTING THE LEAF SPRING BUSHING

- (1) Using the cylinder head, measure the internal diameter of the leaf spring bushing.
 (2) To calculate the clearance, subtract the leaf spring bracket pin diameter from the leaf spring bushing diameter.
 (3) If the measured value exceeds the standard value, replace the defective components (leaf spring bracket pin or leaf spring bushing).

Standard value (mm (in.))	Usable limit (mm (in.))
0.020-0.125	0.5 (0.020)
{0.0008-0.0049}	

CHANGE

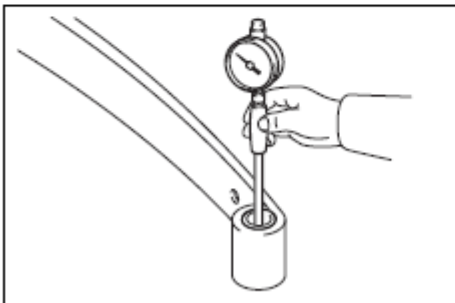

SHTS11ZZZ0600024

