



FIELD SERVICE CAMPAIGN – 16106

24 May 2016

SUBJECT:

Incorrect Mounting Bolts Installed on Front Crossmembers

MODELS INVOLVED:

PayStar®

DEFECT DESCRIPTION:

Certain PayStar® vehicles may have front crossmembers installed with incorrect bolts or missing bolts.

ELIGIBILITY:

This procedure applies ONLY to vehicles marked in the International® Service PortalSM with FSC 16106. Also complete any other open campaigns listed on the Service Portal at this time.

TOOLS REQUIRED:

No special tools are required for this procedure.

PARTS REQUIRED:

Part Number	Description	Quantity
414078C1	BOLT HH FLANGE *5/8-18 UNRF X 2.0	6
414089C1	NUT FLG HD LK 5/8 NF	6

Table 1 Parts Information

WORK INSTRUCTIONS

WARNING! To prevent property damage, personal injury, and / or death, park vehicle on hard flat surface, turn the engine off, set the parking brake, and install wheel chocks to prevent the vehicle from moving in both directions.

WARNING! To prevent property damage, personal injury, and / or death, if the vehicle must be raised, do not work under the vehicle supported only by jacks. Jacks can slip or fall over.

WARNING! To prevent property damage, personal injury, and / or death, keep flames or sparks away from vehicle and do not smoke while servicing the vehicle's batteries. Batteries expel explosive gases.

1. Bring vehicle into shop and park on flat surface.
2. Shift transmission to Park or Neutral and set parking brakes.
3. Install wheel chocks.

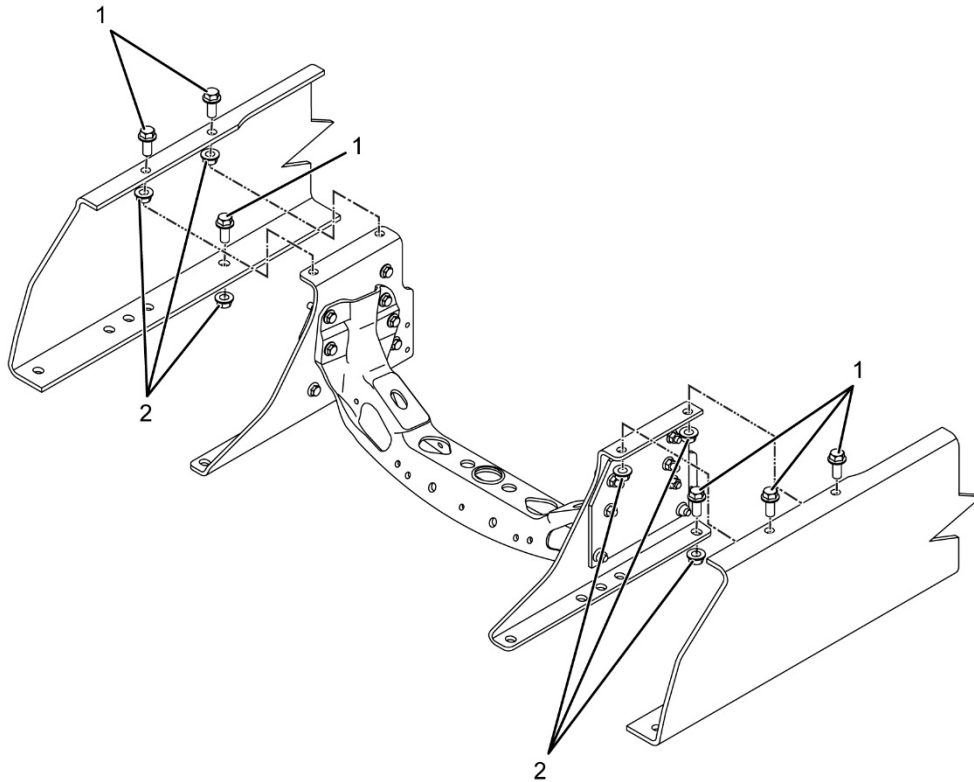

0000399581

Figure 1. Front Crossmember

1. Bolt (6)
2. Nut (6)

CAUTION: To prevent frame damage, do not use a torch / high heat source to cut or remove bolts. Extreme heat can damage frame rail heat treatment.

NOTE: For clarity, only affected fasteners are depicted in graphic.

4. Access front crossmember bolts, remove four upper bolts and nuts and lower rear bolts and nuts (Figure 1, Items 1 and 2). Discard bolts and nuts.
5. Obtain bolts and nuts and install into upper and lower rear crossmember bolt locations. Using torque wrench, tighten new fasteners to 220 lb-ft (298 N·m).
6. Remove wheel chocks.

LABOR INFORMATION

Operation number must appear on all claims.

Table 2 Labor Information

Operation Number	Description	Time
A40-16106-1	Replace Upper Front Crossmember Bolts	0.5 hr

WARRANTY CLAIMS

Warranty claim expense is to be charged to Warranty. Claims are to be submitted in the normal manner, making reference to Field Service Campaign 16106.

It is important that the coding be completed properly to assist in processing the warranty claim. Complete instructions will be found in the Warranty Policy Manual, Section 7.1.8.

As with all claim submissions, items acquired locally must be submitted in the “Other Charges” tab. The cost of any bulk items (such as a bag of cable tie straps, roll of wire, barrel of oil, or tube of silicone) should be prorated for the cost of the individual pieces / amount used during each repair.

To make sure this important improvement is made in a timely manner, all claims for 16106 activity must be submitted by 24 May 2017 or within the normal warranty period for the component, if after 24 May 2017.

	GROUP	NOUN	C	WARR.	TP	PAD

GROUP — Enter number ←

NOUN — Leave blank ←

C (CAUSE) — Enter either 1, 2, 3. (See below)

1. Inspected (No repair required).
2. Inspected and repaired.
3. Defective part from parts stock.

WARRANTY — (Warranty Code) Enter 40. ←

TYPE PART — Enter P for type part causing failure. ←

PAD — Enter 100 ←

000047910