

November 8, 2016

04952 Version 1

Center Display Visor Is Loose or Falling Down

AFFECTED VEHICLES

Year	Model	Trim	VIN Range
2016	Odyssey	ALL	5FNRL5...GB000001 thru 5FNRL5...GB103626

SYMPTOM

The center display visor is loose or falling down.

POSSIBLE CAUSES

The dashboard area where the center display visor clip attaches has part of the clip material missing, causing the center display visor to loosen or fall out.

CORRECTIVE ACTION

Replace the dashboard.

PARTS INFORMATION

Part Name	Part Number	Quantity
Dashboard (NH686L Grey)	77111-TK8-A02ZA	1
Dashboard (NH767L Truffle)	77111-TK8-A02ZB	1
Dashboard (YR400L Beige)	77111-TK8-A02ZC	1
NUT-WASHER (6MM)	90321-SP0-A80	3

WARRANTY CLAIM INFORMATION

The normal warranty applies.

Operation Number	Description	Flat Rate Time	Defect Code	Symptom Code	Template ID	Failed Part Number
841100	Replace the dashboard (NH686L Grey).	3.4 hrs	08001	01801	16-080A	77111-TK8-A01ZA
841100	Replace the dashboard (NH767L Truffle).	3.4 hrs	08001	01801	16-080B	77111-TK8-A02ZB
841100	Replace the dashboard (YR400L Beige).	3.4 hrs	08001	01801	16-080C	77111-TK8-A02ZC

Skill Level: Repair Technician

CUSTOMER INFORMATION: The information in this bulletin is intended for use only by skilled technicians who have the proper tools, equipment, and training to correctly and safely maintain your vehicle. These procedures should not be attempted by "do-it-yourselfers," and you should not assume this bulletin applies to your vehicle, or that your vehicle has the condition described. To determine whether this information applies, contact an authorized Honda automobile dealer.

DIAGNOSIS

1. Remove the center display visor, and inspect the dashboard area as shown.
 - If the dashboard material is missing (no good), go to REPAIR PROCEDURE.
 - If the dashboard material is good, this bulletin does not apply. Continue with normal troubleshooting.

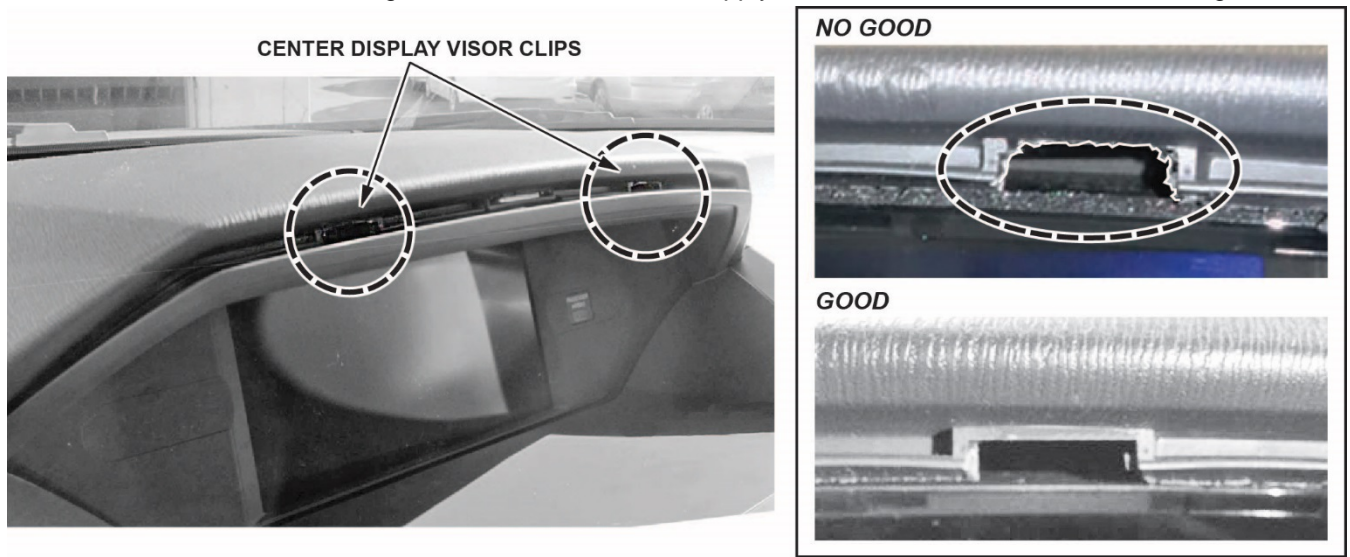

REPAIR PROCEDURE

SRS components are located in this area. Review the SRS component locations and precautions and procedures before doing repairs or service.

NOTE: This procedure is an outline form, if you need more details on this procedure, refer to the service information.

- Have an assistant help you when removing and installing the dashboard.
 - Put on gloves to protect your hands.
 - Take care not to scratch the dashboard, the body, or the related parts.
 - Take care not to bend the brackets.
 - Use the appropriate tool from the KTC trim tool set to avoid damage when removing components.
1. Do the battery terminal disconnection procedure, then wait at least 3 minutes before beginning work.
 2. Remove these items from the dashboard:
 - Detachable console
 - A-pillar upper/lower trims, (both sides)
 - Dashboard side lids, (both sides)
 - Tweeter grilles, (both sides)
 - Driver's middle panel
 - Driver's vent panel
 - Instrument visor
 - Gauge control module
 - Column blind cover
 - Steering column
 - Driver's footwell light connector
 - Center panel
 - Front center speaker grille
 - Shift lever
 - Center lower console
 - Audio display unit (without navigation and without USB adapter)
 - Audio display-USB adapter control unit (without navigation and with USB adapter)
 - Navigation display unit (with navigation)
 - GPS antenna (with navigation)
 - Audio unit (without navigation)
 - Audio-navigation unit (with navigation)

- Glove box
- Passenger's dashboard undercover
- Front passenger's airbag

3. Disconnect the roof wire harness connector from the A-pillar.

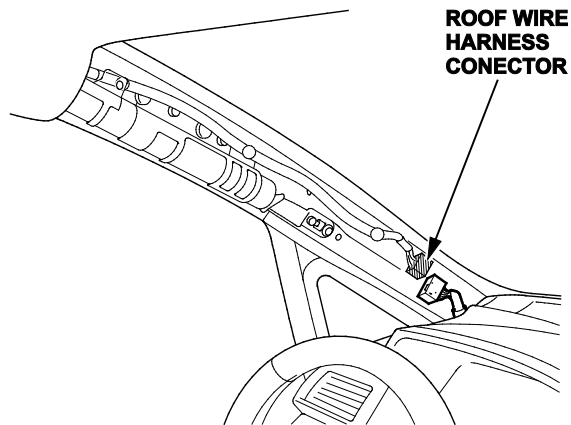

4. Detach the harness clips.

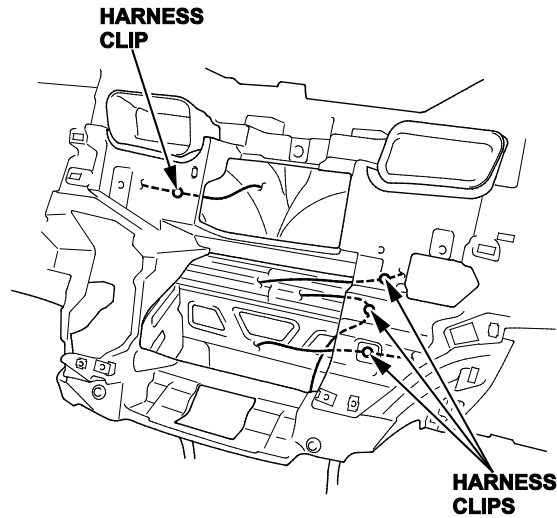
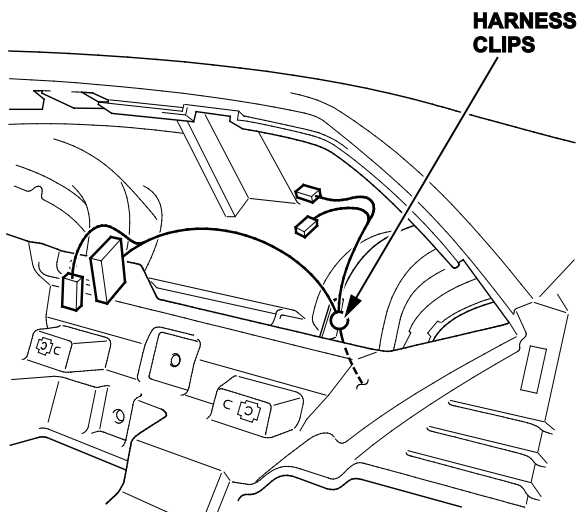

5. Disconnect the roof wire harness connector from the A-pillar.

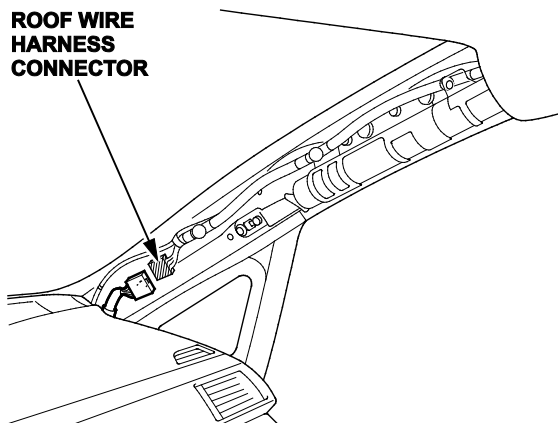

6. Release the glove box light bulb socket, and detach the harness clips. Detach the harness clips (if equipped).

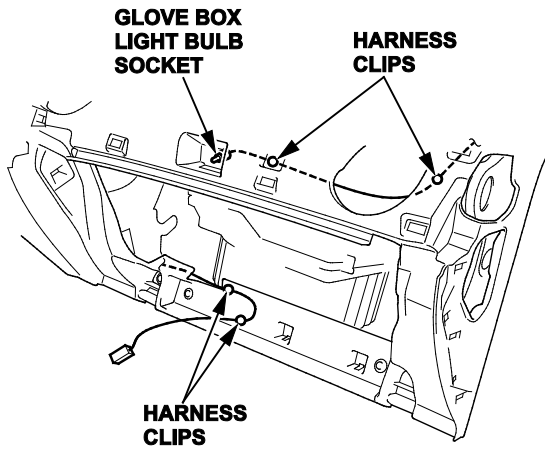

7. Remove the bolts.

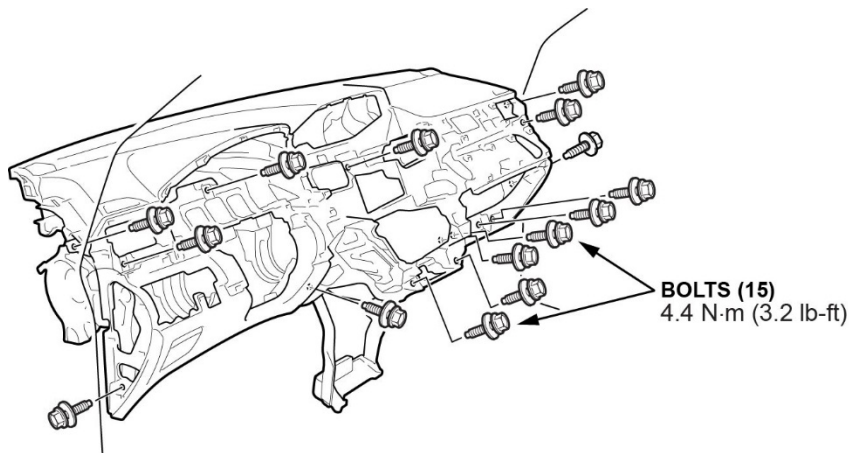

8. Lift up on the dashboard to release it from the guide pins, then carefully remove the dashboard through the front door opening.

NOTE: Do not rest the dashboard on its center lower console opening, or it may be damaged. Lay it on its front or back.

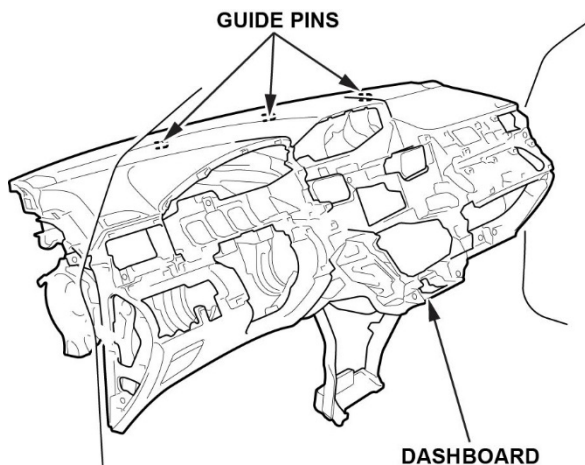

9. Install the dashboard in the reverse order of removal, and note these items:

- Make sure the dashboard fits onto the guide pins correctly.
- Make sure the dashboard wire harness is not pinched before tightening the bolts.
- Make sure each connector is plugged in properly.
- Do the battery terminal reconnection procedure.
- Check for any DTCs that may have been set during repairs, and clear them.
- Replace the passenger side airbag 6 mm nut washers, and torque to **9.4 N·m (6.9 lb-ft)**.

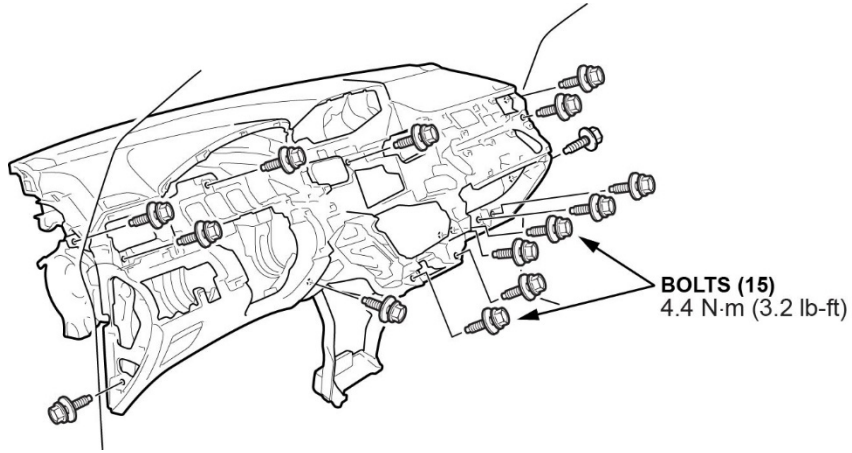

END