

Ninja H2™

**Motorcycle
Assembly & Preparation
Manual**



Kawasaki

Recharge the Battery First!

This motorcycle comes with a pre-filled, pre-charged sealed battery, eliminating the need for dealers to prepare the battery by filling it with electrolyte. However, the battery must be charged upon initial receipt of each unit since it may have been warehoused for a significant time period before being delivered to your dealership.

After the initial charge at your dealership the battery should be recharged every six months. Because the battery will discharge more rapidly at high ambient temperatures, more frequent charging intervals may be required for dealerships located in hot climate zones.

When the battery is not charged periodically during long term storage, its internal resistance increases and could prevent the battery from being recharged. Refer to the "Battery Service" chapter for details.

The battery is located within the crate at the lower left corner indicated with a dotted line. The battery can be removed from the crate for charging by cutting off a portion of the cardboard cover along the dotted line.

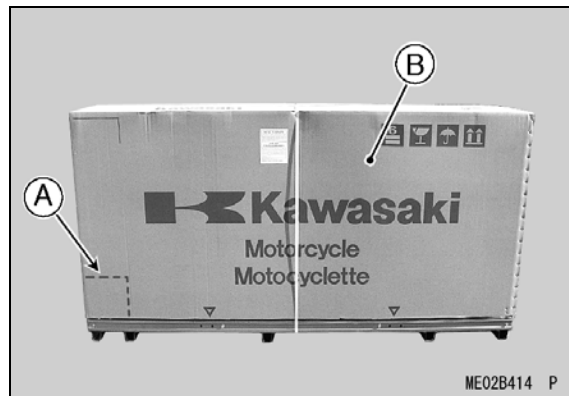

- A. Dotted Line for Battery Location
- B. Cardboard Cover

Foreword

In order to ship Kawasaki vehicles as efficiently as possible, they are partially disassembled before crating. Since some of the most commonly removed parts have a direct bearing on a vehicle's reliability and safety, conscientious pre-sale assembly and preparation becomes extremely important. Good setup procedures can prevent needless warranty claims and give customers a greater sense of confidence in Kawasaki and their Kawasaki Dealers.

This Assembly and Preparation Manual explains step by step procedures of the following items for all Kawasaki Ninja H2.

1. Uncrating
2. Assembly
3. Preparation

The selling dealer assumes sole responsibility for any unauthorized modifications prior to sale. Refer to your Service Binder for any Service Bulletins specifying Factory Directed Modifications (Special Claims) which must be performed before the vehicle is ready for sale.

Whenever you see the following symbols heed their instructions! Always follow safe operating and maintenance practices.

DANGER

DANGER indicates a hazardous situation which, if not avoided, will result in death or serious injury.

WARNING

WARNING indicates a hazardous situation which, if not avoided, could result in death or serious injury.

NOTICE

NOTICE is used to address practices not related to personal injury.

NOTE

○*NOTE* indicates information that may help or guide you in the operation or service of the vehicle.

Kawasaki Heavy Industries, Ltd. accepts no liability for any inaccuracies or omissions in this publication, although every possible measure has been taken to make it as complete and accurate as possible. All procedures and specifications subject to change without notice.

Table of Contents

Uncrating	3
Opening Crate	3
Parts Check	5
Assembly	6
Brake Disc Cleaning	6
French Labels (For Canada Model)	6
Preparation	6
Battery Service	6
Coolant	9
Front Brake	11
Rear Brake	13
Clutch	14
Drive Chain	16
Front Fork	18
Rear Shock Absorber	19
Tire Air Pressures	20
Fuel	21
Engine Oil (4-stroke)	21
Throttle Grip and Cable	22
Rear Brake Light Switch	23
Headlight Aim	23
Digital Meter	24
Fastener Check	26
Standard Torque Table	29
Test Ride the Motorcycle	29
A & P Check List	29

Uncrating

Opening Crate

⚠ WARNING

Crates have sharp edges and may have nails or screws that can cause cuts and injury. Always wear protective gloves, boots and eye protection when uncrating to prevent injury.



MC03003B S

⚠ WARNING

The steel crate panel plates and fasteners have sharp edges. Always wear protective gloves, boots and eye protection when uncrating to prevent injury.



MC03004B S

- Clear a space about 6 m (20 ft) square to give yourself plenty of space to work.
- Place the crate upright on its base.
- Remove the cardboard cover.
- Remove the parts boxes.

NOTICE

When removing the crate bracket from the motorcycle, be careful not to drop any parts or the bracket onto the fuel tank and other components, and not to scratch the fuel tank or other components with the crate bracket.

- Take out all the bolts and screws and remove the top and sides of the crate.
- Loosen the front axle holding nut.
- Remove the left front support bracket bolt and discard it.
- Remove the front axle holding nut, left front support bracket and rubber washers and discard them.

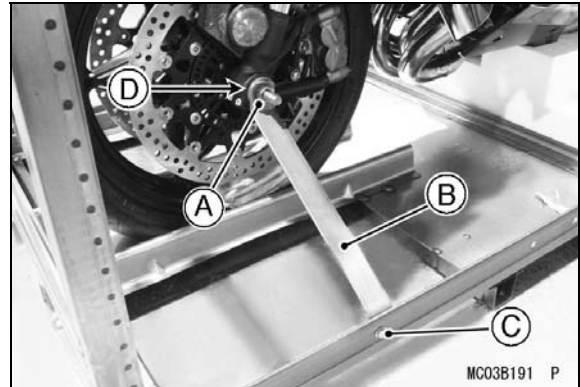

MC03B191 P

- A. Front Axle Holding Nut**
- B. Left Front Support Bracket**
- C. Left Front Support Bracket Bolt**
- D. Rubber Washers**

- Remove the right front support bracket bolt and discard it.
- Remove the front axle holding bolt, right front support bracket and rubber washers and discard them.

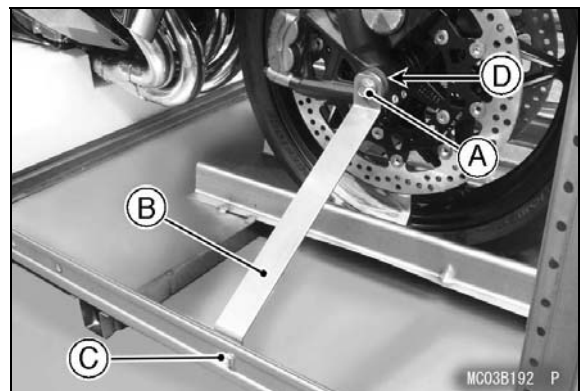

MC03B192 P

- A. Front Axle Holding Bolt**
- B. Right Front Support Bracket**
- C. Right Front Support Bracket Bolt**
- D. Rubber Washers**

- Loosen the pivot holding nut.
- Remove the lower support bracket bolt on the left and right sides and discard them.
- Lift the vehicle upward about 10 cm (4 in.).
- Remove the pivot holding nut, pivot holding bolt, lower support brackets and rubber washers.
- Roll the vehicle off the crate base.

4 UNCRATING

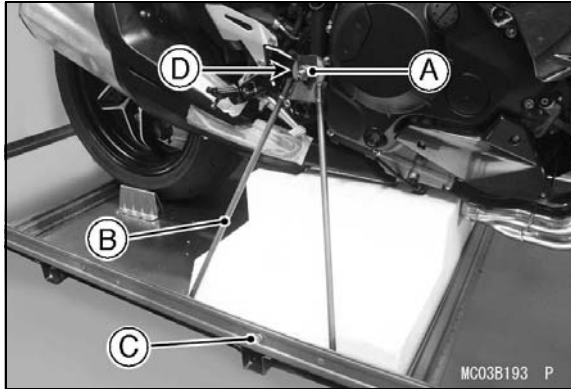

- A. Pivot Holding Nut
- B. Lower Support Bracket
- C. Lower Support Bracket Bolt
- D. Rubber Washer

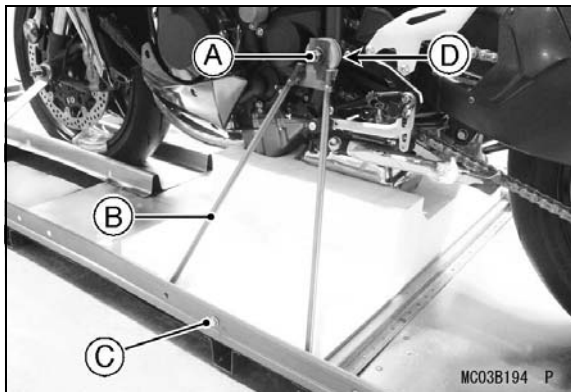

- A. Pivot Holding Bolt
- B. Lower Support Bracket
- C. Lower Support Bracket Bolt
- D. Rubber Washer

NOTICE

When rolling the vehicle off the crate base, sharp edges on the crate can cut or damage tires.
Cover sharp edges with waste cloth for tire protection as necessary.

Parts Check

- Open the parts box, and check the parts against the illustrations. There may be minor differences between these illustrations and the actual vehicle parts. In the following charts under Remarks, D = diameter in millimeters, and L = length in millimeters.

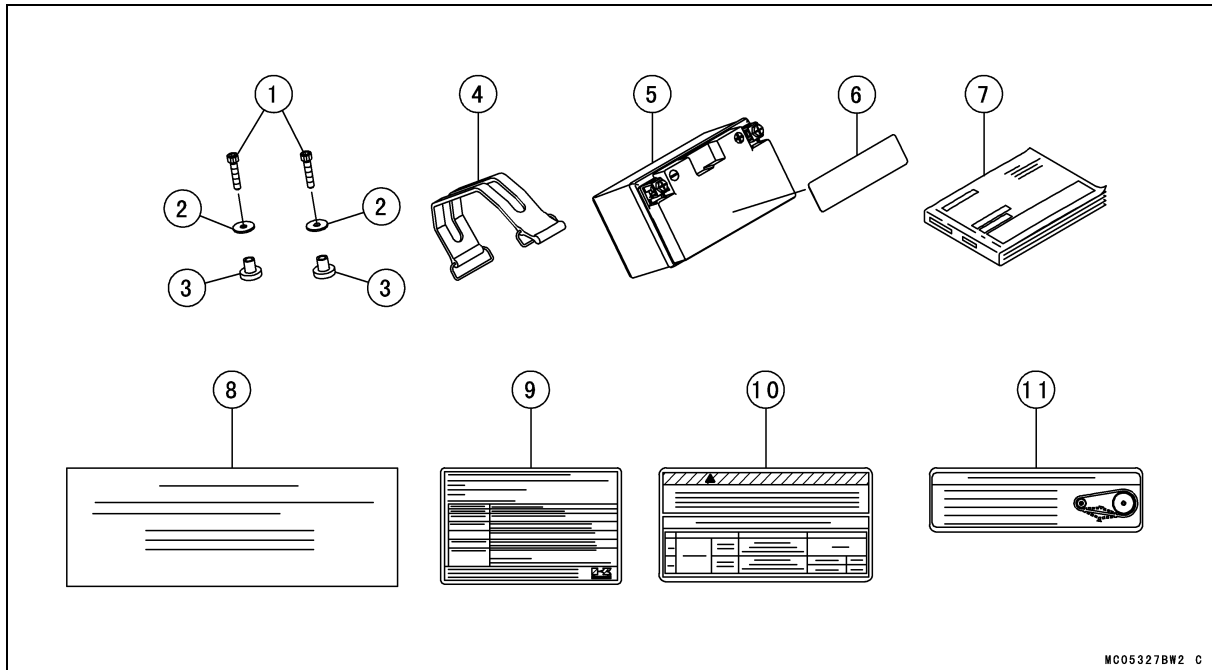

MC05327BW2 C

No.	Part Name	Qty	Remarks
1	Bolt, Seat	2	D = 6, L = 30
2	Washer, Seat	2	D = 20
3	Collar, Seat	2	
4	Band, Battery	1	
5	Battery	1	YTZ10S
6	Pad, Battery	1	
7	Owner's Manual	1	
8	French Labels for Canada Model only		
8	French Table	1	
9	Vehicle Emission Control Information Label	1	
10	Tire and Load Data Label	1	
11	Important Drive Chain Information Label	1	



MC058017 P

No.	Part Name	Qty	Remarks
1	Bag	1	

Assembly

Brake Disc Cleaning

- Clean the front and rear brake discs using oilless solvent.

⚠ WARNING

An anticorrosive treatment applied to the brake discs will increase braking distance and can cause an accident resulting in serious injury or death. Remove the anticorrosive treatment using an oilless solvent.

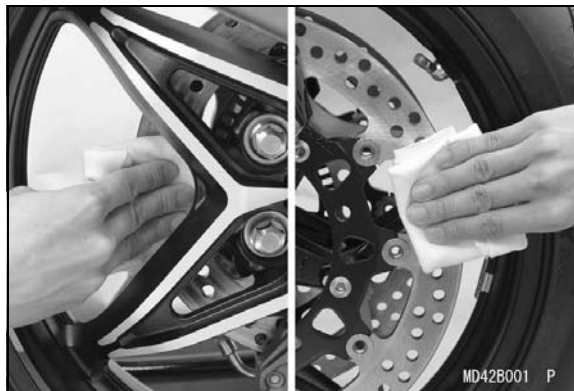

French Labels (For Canada Model)

When required, apply French labels in the parts bag over English labels on the vehicle.

- Wipe off any oil or grease from English labels. Refer to the following figure for the label locations.
- Peel each label in the parts bag off the backing sheet and apply it over English label.

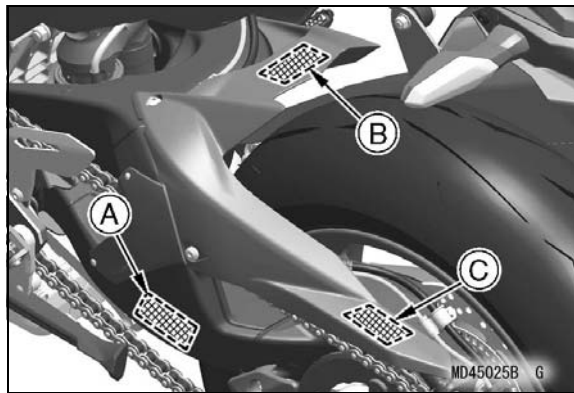

- A. Vehicle Emission Control Information
- B. Tire and Load Data
- C. Important Drive Chain Information

Preparation

Battery Service

Battery Activation

Charged Battery Service

This motorcycle comes with a pre-filled, pre-charged sealed battery, eliminating the need for dealers to prepare the battery by filling it with electrolyte. However, the battery must be charged upon initial receipt of each unit since it may have been warehoused for a significant time period before being delivered to your dealership.

After the initial charge at your dealership the battery should be recharged every six months. Because the battery will discharge more rapidly at high ambient temperatures, more frequent charging intervals may be required for dealerships located in hot climate zones.

NOTICE

This battery is a pre-filled, pre-charged sealed battery. It is not necessary to fill the battery with electrolyte. Do not try to remove the strip of caps.

Battery Recharging

⚠ DANGER

Batteries produce an explosive gas mixture of hydrogen and oxygen that can cause serious injury and burns if ignited. Keep the battery away from sparks and open flames during charging. When using a battery charger, connect the battery to the charger before turning on the charger. This procedure prevents sparks at the battery terminals which could ignite any battery gases.

NOTICE

Always remove the battery from the vehicle for charging. If the battery is charged while still installed, battery electrolyte may spill and corrode the frame or other parts of the motorcycle. Charging the battery at a rate higher than specified may ruin the battery. Charging at a high rate causes excess heat which can warp the plates and cause internal shorting. Higher-than-normal charging rates also cause the plates to shed active material. Deposits will accumulate, and can cause internal shorting. If the temperature of the electrolyte rises above 45°C (113°F) during charging, reduce the charging rate to lower the temperature, and increase charging time proportionately.

NOTE

- Never attempt to charge a frozen battery.
- Allow it to warm up to room temperature before charging.
- Never leave a battery on a trickle charger longer than 48 hours. Serious damage to the battery will occur.
- Always install the red insulating cap to the battery positive (+) terminal while the battery is stored.
- Remove the charging label, tape, terminal bolts, terminal nuts and cap.

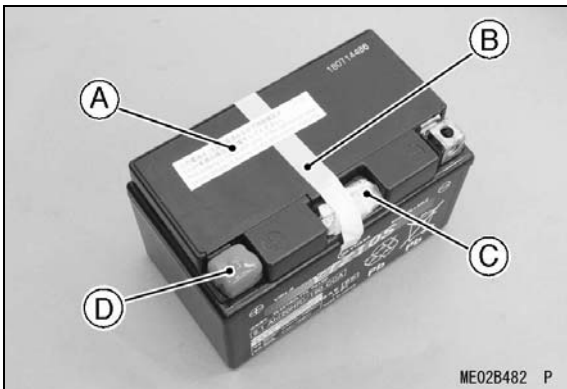

- A. Charging Label**
- B. Tape**
- C. Terminal Bolts and Nuts**
- D. Cap**

- Charge the battery with the standard charging rates indicated on the battery.

Battery types	YTZ10S
Standard Charge	0.9 A × 5 ~ 10 hours

- Use a recommended battery charger, following the manufacturer's instructions.

Kawasaki-recommended chargers:

- Battery Mate 150-9**
- OptiMate PRO 4-S/PRO S/PRO 2**
- Yuasa MB-2040/2060**
- Christie C10122S**

- If the recommended chargers are not available, use equivalent one.

NOTE

- Charging rates will vary depending on how long the battery has been stored, temperature, and the type of charger used.
- Determine battery condition after charging.

NOTE

- Determine the condition of the battery 30 minutes after completion of the charge by measuring the terminal voltage according to the table below.

Criteria	Judgement
12.8 V or higher	Good
12.0 ~ 12.8 V	Charge insufficient → Recharge
12.0 V or lower	Unserviceable → Replace

NOTE

- If it is less than 12.8 volts, repeat charging cycle.
- If the minimum voltage specification cannot be reached after three consecutive charging attempts, the battery should be replaced.
- After recharging, record the charging date and the name of person in charge of this job to the label attached on the battery.

8 PREPARATION

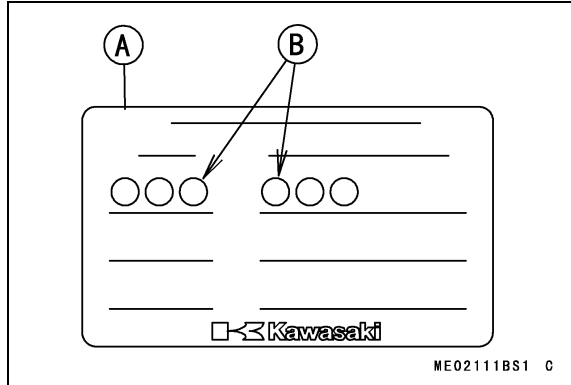

A. Recharging Record Label

B. Record the Charging Date and the Name of Person Here.

- The battery recharging record label is attached on the battery side as shown.

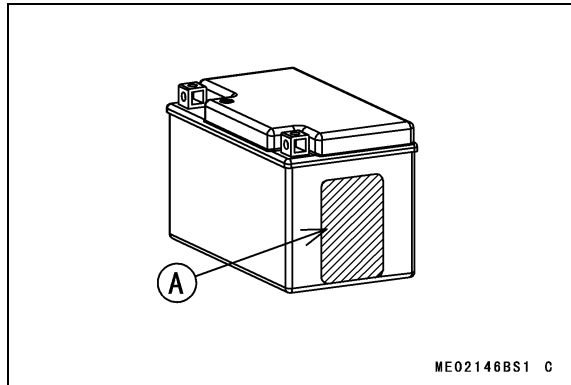

A. Battery Recharging Record Label

- The battery manufacturing date is printed on battery top.

Example) 01 09 10 XX
 Day Month Year Mfg. location

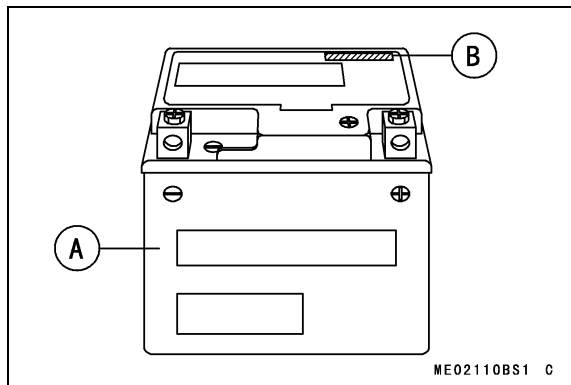

A. Battery

B. Manufacturing Date

Battery Installation

- Inspect the battery voltage using a voltmeter, and recharge the battery if the voltage reading is below 12.8 volts just before delivering to your customer to ensure the maximum performance and customer satisfaction. (Refer to the "Battery Recharging" section.)
- Wipe off any dirt of the battery.
- Apply pad to the battery as shown.

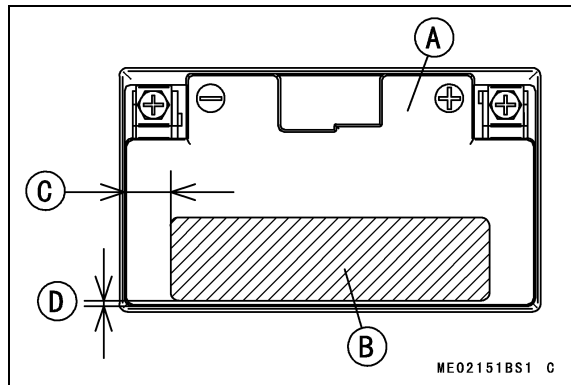

A. Battery

B. Pad

C. About 16.5 mm (0.65 in.)

D. About 2 mm (0.08 in.)

- Turn the ignition switch off.
- Insert the ignition key into the seat lock.
- Remove the seat pad while turning the key clockwise and moving the seat pad a little to the right and left.

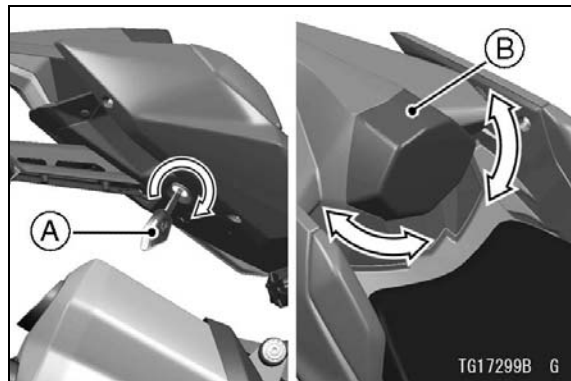

A. Ignition Key

B. Seat Pad

- Pull the seat rearward to clear the hooks.
- Remove the seat.

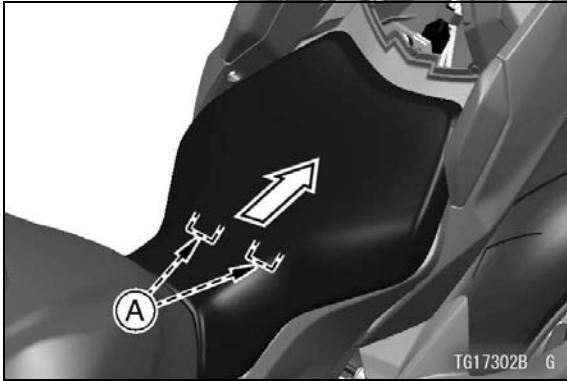

A. Hooks

- Place the battery on the battery case.
- Connect the red capped positive cable to the (+) terminal first.
- Then connect the negative cable to the (-) terminal.

NOTE

○When installing the terminals, make the gaps between the terminals and battery.

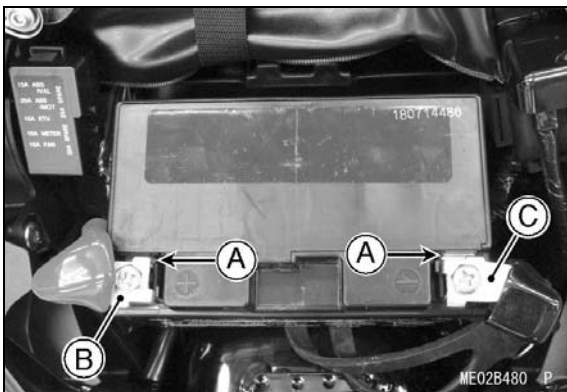

A. Gaps

- B. Positive (+) Terminal**
- C. Negative (-) Terminal**

- Put a light coat of grease on the terminals to prevent corrosion.
- Cover the terminals with the caps.
- Install the band to hold the battery and positive cable.

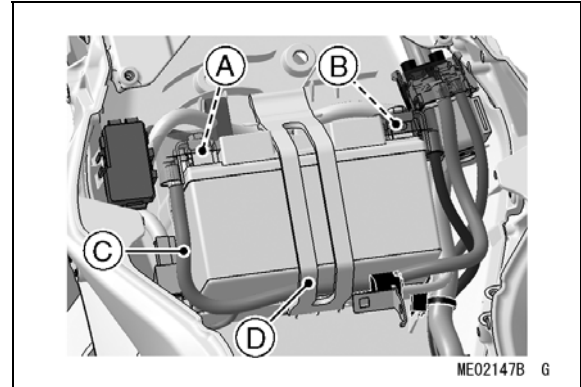

- A. Positive (+) Terminal**
- B. Negative (-) Terminal**
- C. Positive Cable**
- D. Band**

Coolant

Coolant Level Inspection

- Position the motorcycle so that it is perpendicular to the ground.
- Check the coolant level through the coolant level gauge on the reserve tank located to the behind of the right middle fairing. The coolant level should be between the F (Full) and L (Low) level lines.

NOTE

○Check the level when the engine is cold (room or atmospheric temperature).

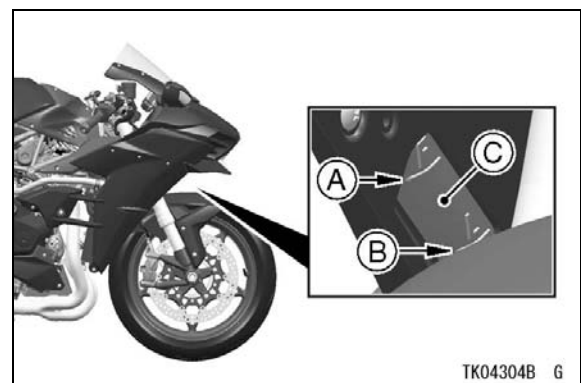

- A. F (Full) Level Line**
- B. L (Low) Level Line**
- C. Reserve Tank**

- If the amount of coolant is insufficient, add coolant into the reserve tank.

Coolant filling

- Remove the inner cover bolts.

10 PREPARATION

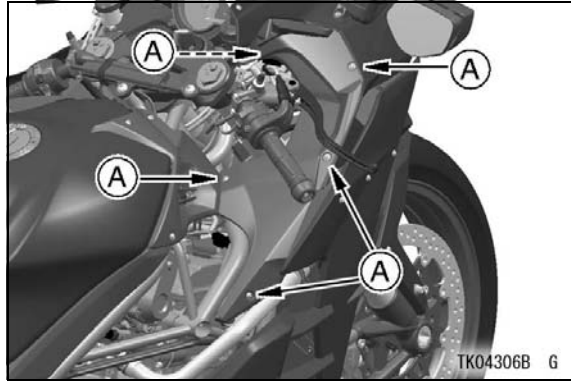

A. Inner Cover Bolts

- Pull up the right inner cover to clear the tabs.

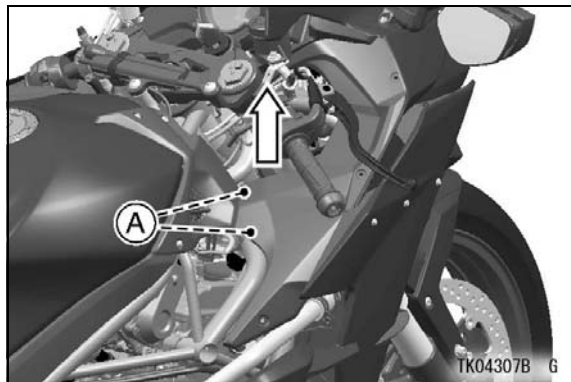

A. Tabs

- Pull the right inner cover rearward to clear the projection.

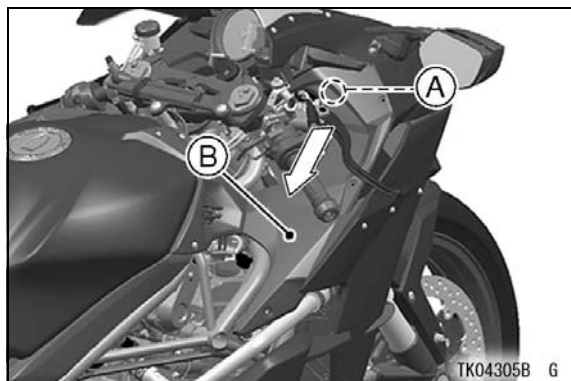

A. Projection

B. Right Inner Cover

- Remove the cap from the reserve tank and add coolant through the filler opening to the F (Full) level line.

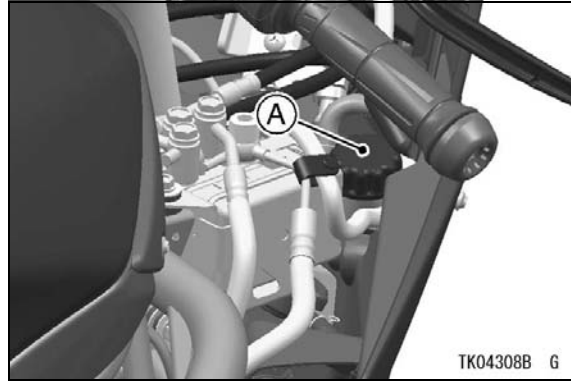

A. Reserve Tank Cap

NOTE

○ A permanent type of antifreeze is installed in the cooling system when shipped. It is mixed at 50% and has the freezing point of -35°C (-31°F).

- Install the reserve tank cap.
- Insert the projection of the right inner cover into the grommet on the upper fairing.

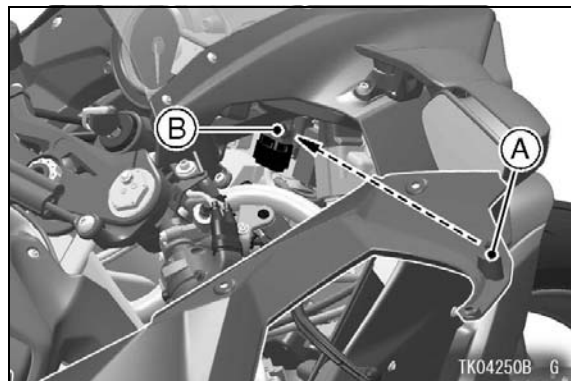

A. Projection

B. Grommet

- Insert the tabs on the right inner cover into the slots of the right fuel tank cover.

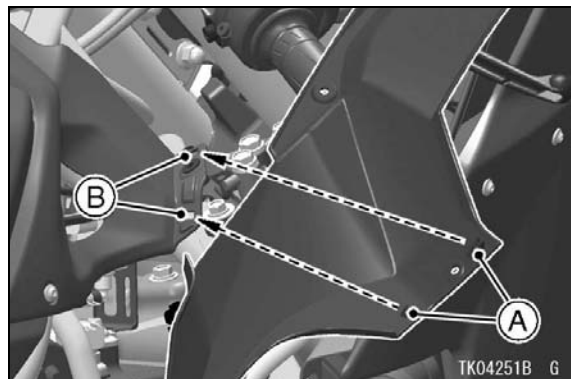

A. Tabs

B. Slots

- Tighten the inner cover bolts.

Front Brake

Brake Hose Inspection

- Check that the brake hose are routed correctly.

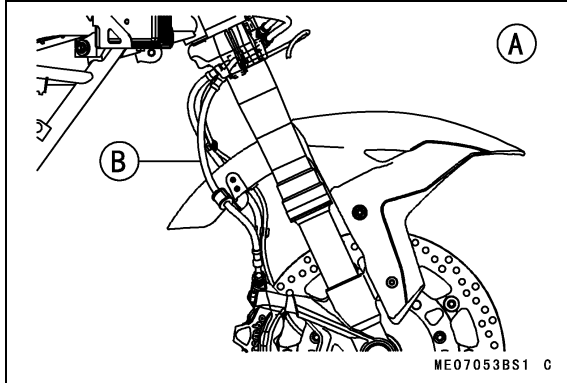

- A. Good
- B. Brake Hose

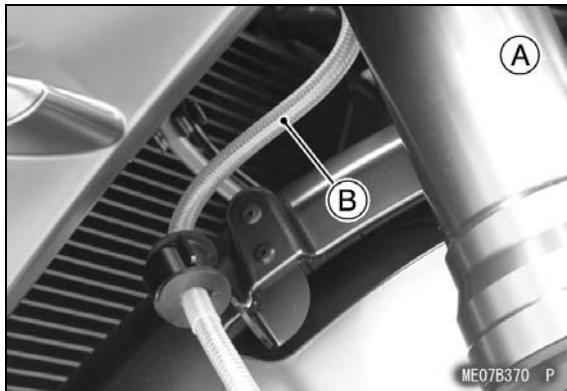

- A. Bad
- B. Brake Hose

Front Brake Fluid Level Inspection

- With the front brake fluid reservoir held horizontal, check that the fluid level is between the upper and lower level lines.

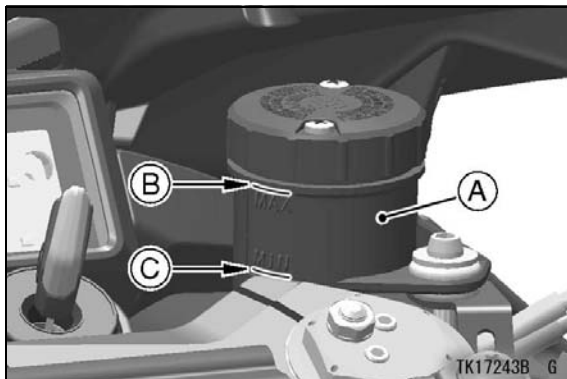

- A. Front Brake Fluid Reservoir
- B. Upper Level Line
- C. Lower Level Line

- If the fluid level in the reservoir is lower than the lower level line, check for fluid leaks in the front brake lines and fill the reservoir.
- Loosen the reservoir cap screws to remove the front brake fluid reservoir cap and diaphragm.
- Fill the reservoir to the upper level line with DOT4 brake fluid, reinstall the diaphragm and reservoir cap.
- Tighten the reservoir cap screws to the specified torque.

Torque: 0.70 N·m (0.07 kgf·m, 6.2 in·lb)

⚠ WARNING

When working with the disc brake, observe the precautions listed below.

- **Never reuse old brake fluid.**
- **Do not use fluid from a container that has been left unsealed or that has been open for a long time.**
- **Do not mix two types and brands of fluid for use in the brake. This lowers the brake fluid boiling point and could cause the brake to be ineffective. It may also cause the rubber brake parts to deteriorate.**
- **Do not leave the reservoir cap off for any length of time to avoid moisture contamination of the fluid.**
- **Do not change the fluid in the rain or when a strong wind is blowing.**
- **Brake fluid quickly damages painted surfaces; any spilled fluid should be completely wiped up immediately.**
- **If any of the brake line fittings or the bleed valve is opened at any time, the AIR MUST BE BLED FROM THE BRAKE LINE.**

- Operate the brake lever several times.
- If it feels spongy, there might be air in the brake line.
- If necessary, bleed the air in the front brake line.
- Also check for fluid leakage around the fittings.

Brake Line Air Bleeding

- Loosen the reservoir cap screws to remove the front brake fluid reservoir cap and diaphragm, and check that there is plenty of fluid in the reservoir.

12 PREPARATION

NOTE

- *The fluid level must be checked several times, during the bleeding operation and replenished as necessary. If the fluid in the reservoir runs completely out any time during bleeding, the bleeding operation must be repeated from the beginning since air will have entered the line.*
- Attach a clear plastic hose to the bleed valve on the front master cylinder and run the other end of the hose into a container.
- With the reservoir cap off, slowly pump the brake lever several times until no air bubbles can be seen rising up through the fluid from the holes at the bottom of the reservoir. This bleeds the air from the brake master cylinder end of the line.
- Pump the brake lever a few times until it becomes hard and then, holding the lever squeezed, quickly open (turn counterclockwise) and close the bleed valve. Then release the lever. Repeat this operation until no more air can be seen coming out into the plastic hose.

NOTICE

After pumping the brake lever several times, releasing it without opening and closing of the bleed valve may cause brake fluid to be blown back from the master cylinder reservoir. Brake fluid spilt on painted surfaces and plastic parts will quickly damage them. Be sure to open and close the bleed valve.

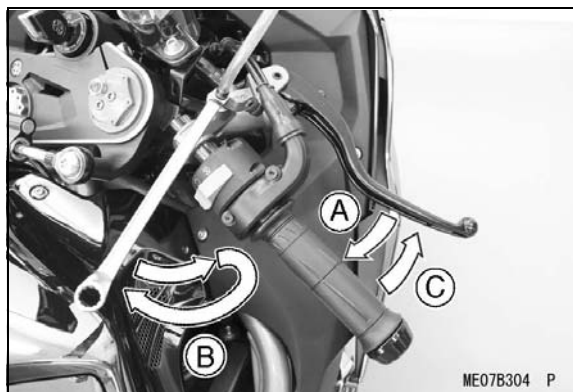

- A. Hold the brake lever applied.
- B. Quickly open and close the bleed valve on the front master cylinder.
- C. Release the brake lever.

- Tighten the front master cylinder bleed valve to the specified torque.

Torque: 5.5 N·m (0.56 kgf·m, 49 in·lb)

- Attach a clear plastic hose to the bleed valve on each front brake caliper and run the other end of the hose into a container.
- With the reservoir cap off, slowly pump the brake lever several times until no air bubbles can be seen rising up through the fluid from the holes at the bottom of the reservoir. This bleeds the air from the brake master cylinder end of the line.
- Pump the brake lever a few times until it becomes hard and then, holding the lever squeezed, quickly open (turn counterclockwise) and close the bleed valve. Then release the lever. Repeat this operation until no more air can be seen coming out into the plastic hose.

NOTICE

After pumping the brake lever several times, releasing it without opening and closing of the bleed valve may cause brake fluid to be blown back from the master cylinder reservoir. Brake fluid spilt on painted surfaces and plastic parts will quickly damage them. Be sure to open and close the bleed valve.

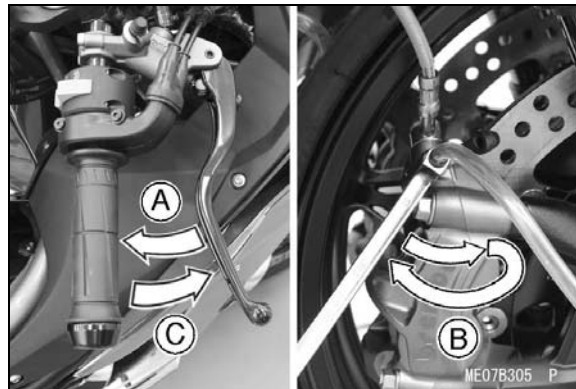

- A. Hold the brake lever applied.
- B. Quickly open and close the bleed valve on the front brake caliper.
- C. Release the brake lever.

- Repeat the previous step one more time for the other front disc brake.
- When air bleeding is finished, check that the fluid level is between the upper and lower level lines.
- Tighten the front caliper bleed valve(s) to the specified torque.

Torque: 16 N·m (1.6 kgf·m, 12 ft·lb)

- Reinstall the diaphragm and reservoir cap.
- Tighten the reservoir cap screws to the specified torque.

Torque: 0.70 N·m (0.07 kgf·m, 6.2 in·lb)

- Apply the brake forcefully for a few seconds, and check for fluid leakage around the fittings.

Rear Brake

Rear Brake Fluid Level Inspection

- With the rear brake fluid reservoir held horizontal, check that the fluid level is between the upper and lower level lines.

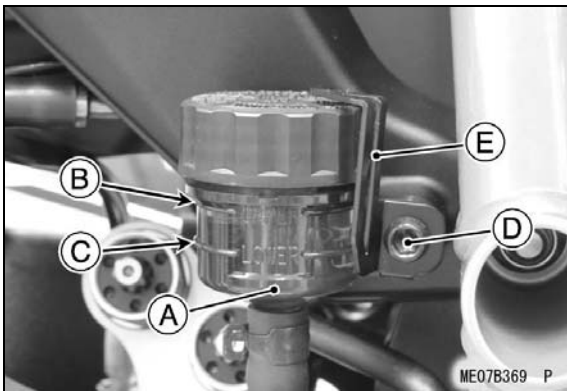

- A. Rear Brake Fluid Reservoir**
- B. Upper Level Line**
- C. Lower Level Line**
- D. Reservoir Cap Stopper Bolt**
- E. Reservoir Cap Stopper**

- If the fluid level in the reservoir is lower than the lower level line, check for fluid leaks in the brake line, and fill the reservoir.
- Loosen the reservoir cap stopper bolt to remove the reservoir cap stopper, reservoir cap and diaphragm.
- Fill the reservoir to the upper level line with DOT4 brake fluid, reinstall the diaphragm and reservoir cap.

NOTICE

Brake fluid quickly damages painted surfaces. Wipe up any spilled fluid immediately.

NOTE

- First, tighten the rear brake fluid reservoir cap clockwise by hand until slight resistance is felt indicating that the cap is seated on the reservoir body, then tighten the cap an additional 1/6 turn while holding the brake fluid reservoir body.

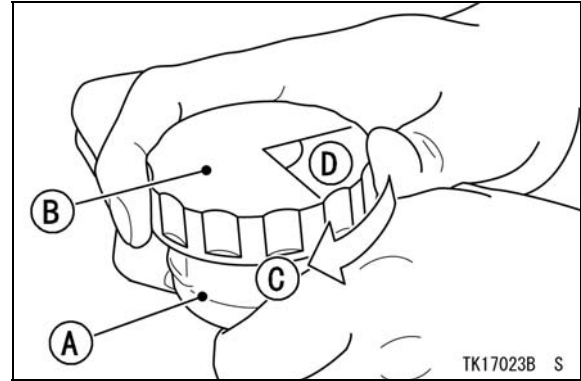

- A. Rear Brake Fluid Reservoir**
- B. Reservoir Cap**
- C. Clockwise**
- D. 1/6 turn**

- Reinstall the reservoir cap stopper.
- Tighten the reservoir cap stopper bolt.
- Operate the brake pedal several times.
- If it feels spongy, there might be air in the brake line.
- If necessary, bleed the air in the rear brake line.
- Also check for fluid leakage around the fittings.

Brake Line Air Bleeding

- Remove the rear caliper mounting bolts.



- A. Rear Caliper Mounting Bolts**

- Loosen the reservoir cap stopper screw to remove the rear brake reservoir cap and diaphragm, and check that there is plenty of fluid in the reservoir.

NOTE

- The fluid level must be checked several times, during the bleeding operation and replenished as necessary. If the fluid in the reservoir runs completely out any time during bleeding, the bleeding operation must be repeated from the beginning since air will have entered the line.

14 PREPARATION

- Face the bleed valve upward.
- Attach a clear plastic hose to the bleed valve on the rear brake caliper and run the other end of the hose into a container.
- Install the suitable plate between the brake pads.

NOTE

○Rear brake disk thickness is the 5 mm (0.20 in.).

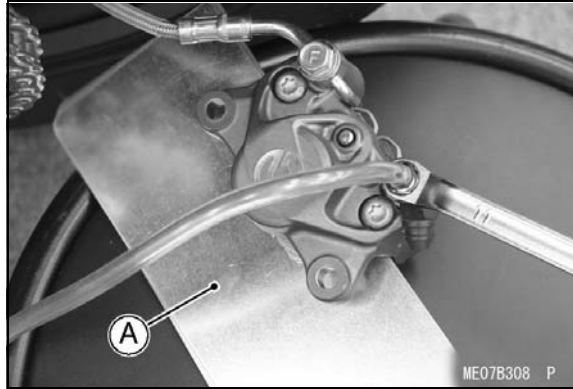

A. Suitable Plate

- With the reservoir cap off, slowly pump the brake pedal several times until no air bubbles can be seen rising up through the fluid from the holes at the bottom of the reservoir. This bleeds the air from the rear brake master cylinder end of the line.
- Pump the brake pedal a few times until it becomes hard and then, holding the pedal pushed down, quickly open (turn counter-clockwise) and close the bleed valve. Then release the pedal. Repeat this operation until no more air can be seen coming out into the plastic hose.

NOTICE

After pumping the brake pedal several times, releasing it without opening and closing of the bleed valve may cause brake fluid to be blown back from the master cylinder reservoir. Brake fluid spilt on painted surfaces and plastic parts will quickly damage them. Be sure to open and close the bleed valve.

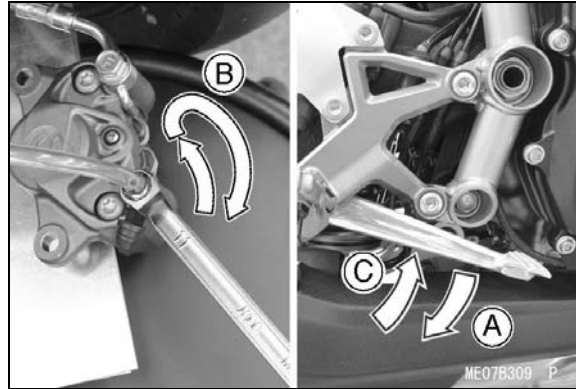

A. Hold the brake pedal applied.

B. Quickly open and close the bleed valve on the rear brake caliper.

C. Release the brake pedal.

- When air bleeding is finished, check that the fluid level is between the upper and lower level lines.
- Tighten the rear caliper bleed valve to the specified torque.

Torque: 16 N·m (1.6 kgf·m, 12 ft·lb)

- Reinstall the diaphragm and reservoir cap.

NOTE

○First, tighten the rear brake fluid reservoir cap clockwise by hand until slight resistance is felt indicating that the cap is seated on the reservoir body, then tighten the cap an additional 1/6 turn while holding the brake fluid reservoir body.

- Reinstall the reservoir cap stopper.
- Tighten the reservoir cap stopper bolt.
- Tighten the rear caliper mounting bolts to the specified torque.

Torque: 27 N·m (2.8 kgf·m, 20 ft·lb)

- Apply the brake forcefully for a few seconds, and check for fluid leakage around the fittings.

Clutch

Clutch Fluid Level Inspection

- With the clutch fluid reservoir held horizontal, check that the fluid level is between the upper and lower level lines.

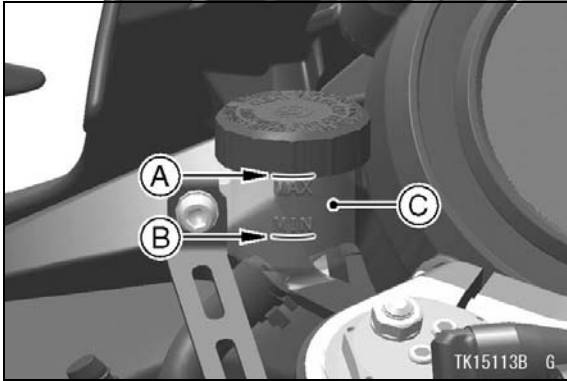

- A. Upper Level Line**
- B. Lower Level Line**
- C. Clutch Fluid Reservoir**

- If the fluid level in the reservoir is lower than the lower level line, check for fluid leaks in the clutch line and fill the reservoir.
- Remove the clutch fluid reservoir cap and diaphragm.
- Fill the reservoir to the upper level line with DOT4 clutch fluid, and reinstall the diaphragm.
- Tighten the reservoir cap to the specified torque (for reference).

Torque: 1.5 N·m (0.15 kgf·m, 13 in·lb)

- Operate the clutch lever several times.
- If it feels spongy, there might be air in the clutch line.
- If necessary, bleed the air in the clutch lines.
- Also check for fluid leakage around the fittings.

Clutch Line Air Bleeding

- Remove the reservoir cap and diaphragm, and check that there is plenty of fluid in the reservoir.

NOTE

○ *The fluid level must be checked several times, during the bleeding operation and replenished as necessary. If the fluid in the reservoir runs completely out any time during bleeding, the bleeding operation must be repeated from the beginning since air will have entered the line.*

- Attach a clear plastic hose to the bleed valve on the clutch master cylinder and run the other end of the hose into a container.
- With the reservoir cap off, slowly pump the clutch lever several times until no air bubbles can be seen rising up through the fluid from the holes at the bottom of the reservoir. This bleeds the air from the clutch master cylinder end of the line.

- Pump the clutch lever a few times until it becomes hard and then, holding the lever squeezed, quickly open (turn counterclockwise) and close the bleed valve. Then release the lever. Repeat this operation until no more air can be seen coming out into the plastic hose.

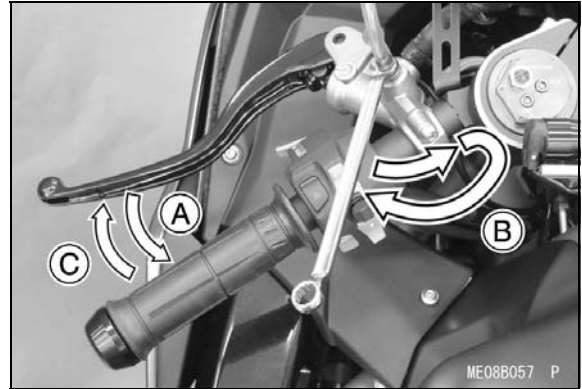

- A. Hold the clutch lever applied.**
- B. Quickly open and close the bleed valve on the clutch master cylinder.**
- C. Release the clutch lever.**

- Tighten the clutch master cylinder bleed valve to the specified torque.

Torque: 5.5 N·m (0.56 kgf·m, 49 in·lb)

- Attach a clear plastic hose to the bleed valve on the clutch slave cylinder and run the other end of the hose into a container.
- With the reservoir cap off, slowly pump the clutch lever several times until no air bubbles can be seen rising up through the fluid from the holes at the bottom of the reservoir. This bleeds the air from the clutch slave cylinder end of the line.
- Pump the clutch lever a few times until it becomes hard and then, holding the lever squeezed, quickly open (turn counterclockwise) and close the bleed valve. Then release the lever. Repeat this operation until no more air can be seen coming out into the plastic hose.

16 PREPARATION

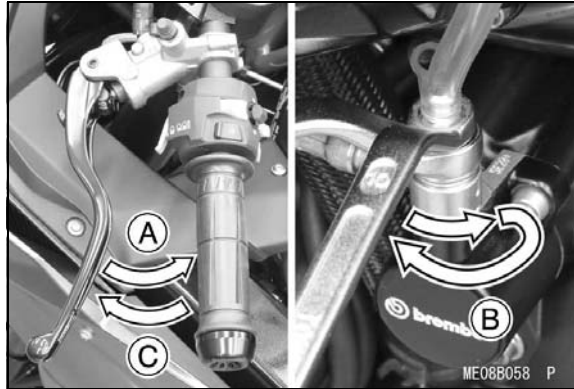

- A. Hold the clutch lever applied.**
- B. Quickly open and close the bleed valve on the clutch slave cylinder.**
- C. Release the clutch lever.**

- When air bleeding is finished, check that the fluid level is between the upper and lower level lines.
- Tighten the clutch slave cylinder bleed valve to the specified torque.

Torque: 7.9 N·m (0.81 kgf·m, 70 in·lb)

- Reinstall the diaphragm.
- Tighten the reservoir cap to the specified torque (for reference).

Torque: 1.5 N·m (0.15 kgf·m, 13 in·lb)

- Apply the clutch forcefully for a few seconds, and check for fluid leakage around the fittings.

Drive Chain

Drive Chain Slack Inspection

- Set the motorcycle up on its side stand.
- Rotate the rear wheel to find the position where the chain is tightest, and measure the maximum chain slack by pulling up and pushing down the chain midway between the engine sprocket and rear wheel sprocket.

Drive Chain Slack:

25 ~ 35 mm (1.0 ~ 1.4 in.)

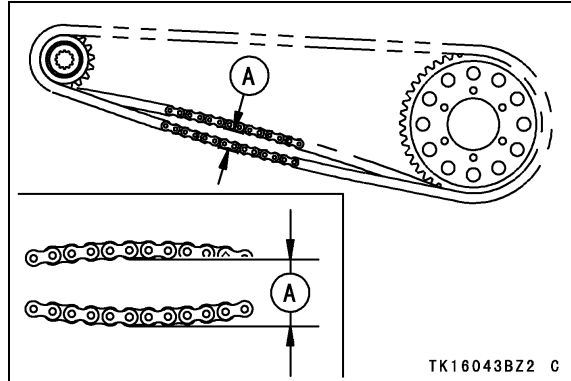

A. 25 ~ 35 mm (1.0 ~ 1.4 in.)

- If the drive chain is too tight or too loose, adjust it so that the chain slack will be within the standard value.

⚠ WARNING

A chain that breaks or jumps off the sprockets could snag on the engine sprocket or lock the rear wheel, severely damaging the motorcycle and causing it to go out of control. Inspect the chain for damage and proper adjustment.

Drive Chain Slack Adjustment

- Remove the hook wrench by removing the hook wrench mounting bolts.

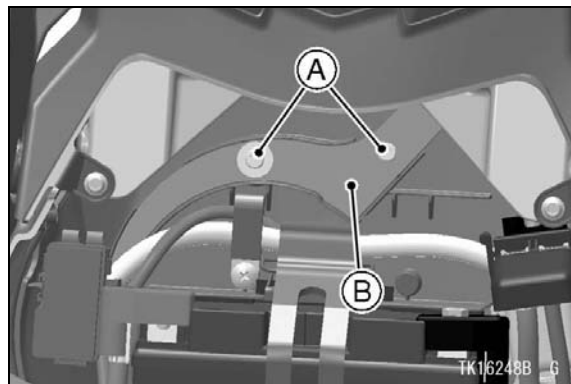

A. Hook Wrench Mounting Bolts

B. Hook Wrench

- Attach the adapter in tool kit to the hook wrench.

NOTE

- *The adapter of the hook wrench is in the tool kit bag.*

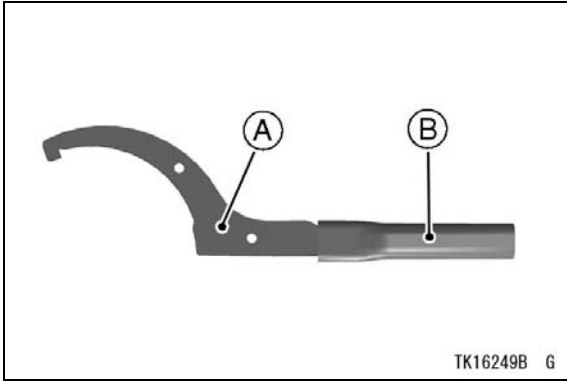

A. Hook Wrench
B. Adapter

- Loosen the bearing housing clamp bolts gradually and evenly.

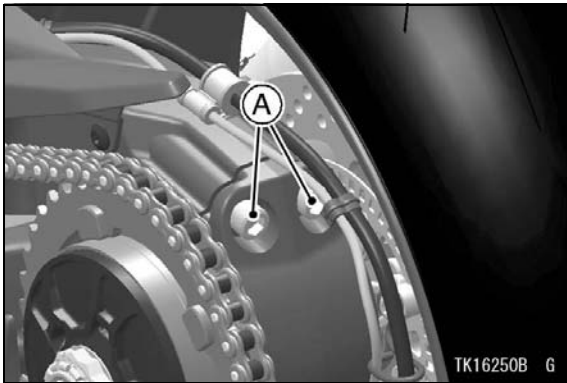

A. Clamp Bolts

- Turn the chain adjuster until the drive chain has correct amount of slack with the hook wrench.
- If the chain is too loose, turn the chain adjuster counterclockwise.
- If the chain is too tight, turn the chain adjuster clockwise.

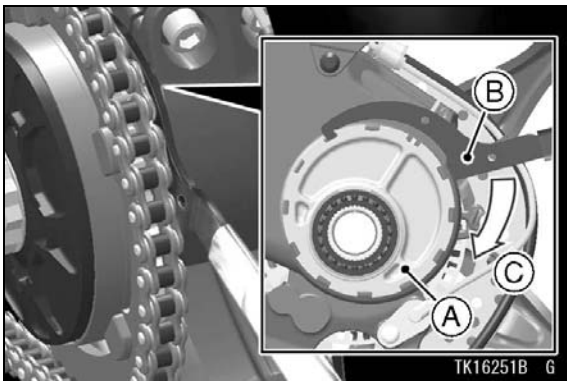

A. Chain Adjuster
B. Hook Wrench
C. Clockwise (direction to loose)

- Pushing the rear wheel to the right side of the vehicle.
- Confirm that there is not a clearance between the chain adjuster and the swingarm.

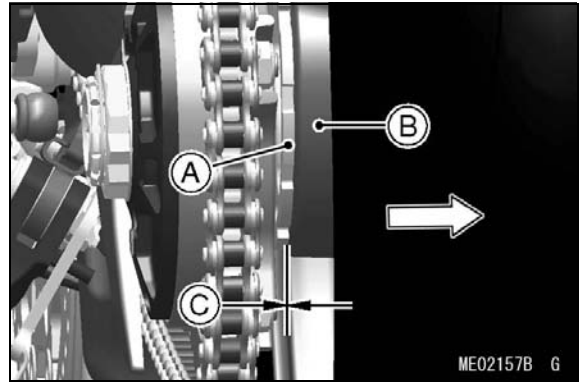

A. Chain Adjuster
B. Swingarm
C. No Clearance

- Tighten the bearing housing clamp bolts to the specified torque following the tightening sequence (A → B → A → B → A → B → A).

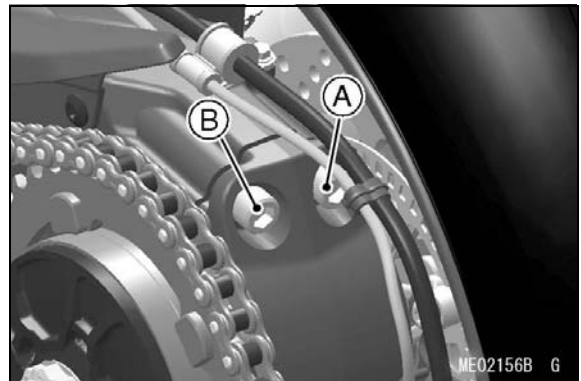

Torque: 33 N·m (3.4 kgf·m, 24 ft·lb)

- Install the hook wrench in the original place, and tighten its bolts.
- Check the rear brake effectiveness.
- Install the collars.

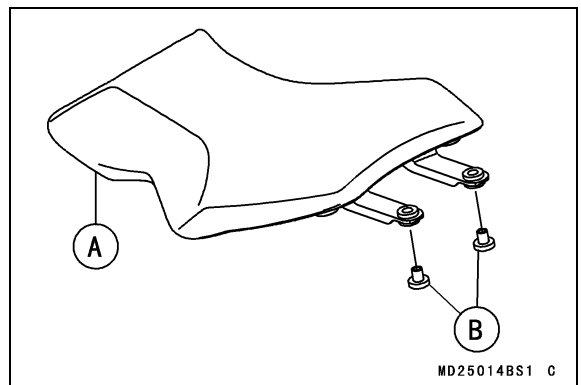

A. Seat
B. Collars

18 PREPARATION

- Insert the rear part of the seat under the seat cover.
- Insert the hooks at the front part of the seat under the fuel tank bracket.

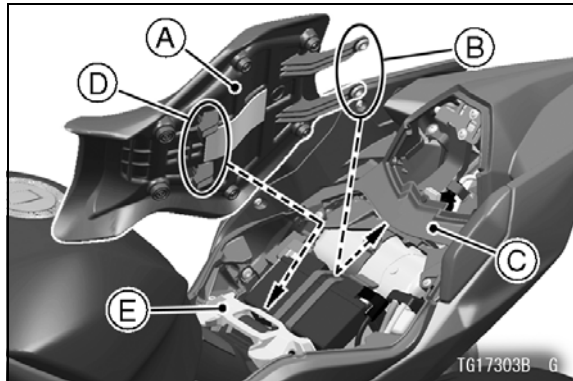

- A. Seat
- B. Rear Part of Seat
- C. Seat Cover
- D. Hooks
- E. Fuel Tank Bracket

- Tighten the seat bolts with the washers.
Torque: 6.9 N·m (0.70 kgf·m, 61 in·lb)
- Insert the seat pad bracket into the slot of the frame.
- Insert the seat pad hook into the latch hole.
- Push the seat pad until the lock clicks.

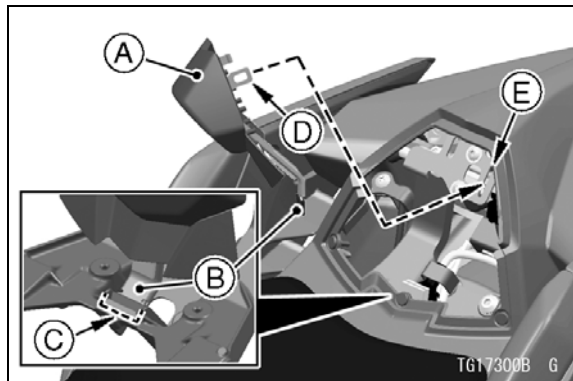

- A. Seat Pad
- B. Bracket
- C. Slot
- D. Hook
- E. Latch Hole

NOTE

○ If the seat pad is not installed in the correct position, there is a gap between the seat pad cover and the seat cover. If there is a gap, reinstall the seat pad.

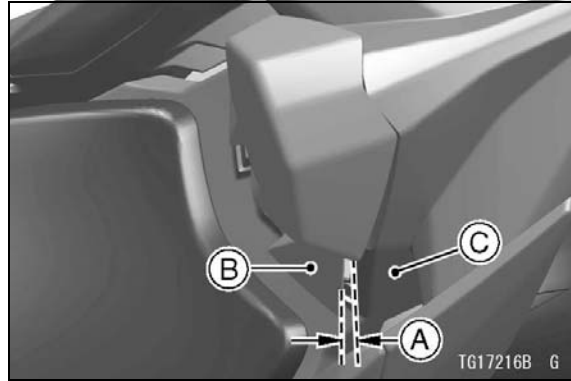

- A. Gap
- B. Seat Pad Cover
- C. Seat Cover

Front Fork

⚠ WARNING

If both spring preload adjusters and both rebound and compression damping force adjusters are not adjusted equally, handling may be impaired and a hazardous condition may result. Set all suspension adjusters equally to the recommended settings.

Spring Preload Adjustment

- Check the position of the spring preload adjusters on the each fork leg.

STD Spring Preload:

10 turns in (Clockwise from the fully seated position).

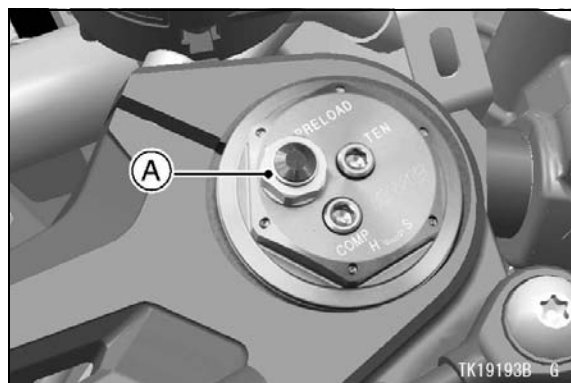

A. Spring Preload Adjuster

- To adjust the spring preload, turn the adjuster with a suitable tool. Adjust the spring preload to the standard setting position.

NOTICE

Do not turn the adjuster beyond the fully seated position or the adjusting mechanism may be damaged.

Rebound Damping Force Adjustment

- Check the position of the rebound damping force adjusters on the each fork leg.

STD Rebound Damping Force:

13 clicks (Counterclockwise from the fully seated position).

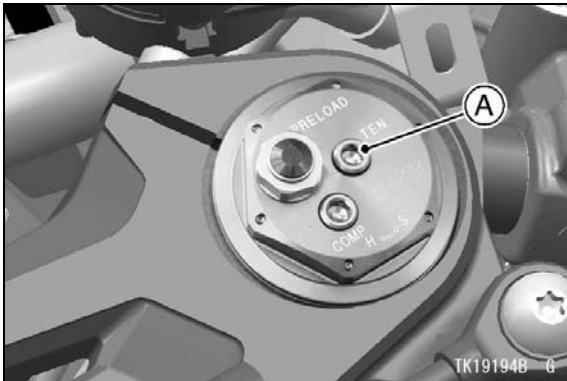

A. Rebound Damping Force Adjuster

- To adjust the rebound damping force, turn the adjuster with a Allen wrench. Adjust the rebound damping force to the standard setting position.

NOTICE

Do not force to turn the rebound damping force adjuster from the fully seated position or the adjusting mechanism may be damaged.

Compression Damping Force Adjustment

- Check the position of the compression damping force adjuster on the each fork leg.

STD Compression Damping Force:

10 clicks (Counterclockwise from the fully seated position).

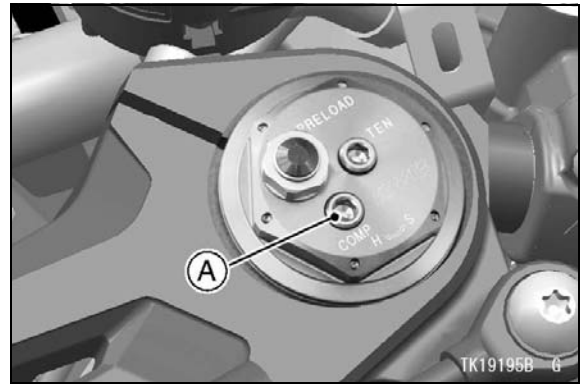

A. Compression Damping Force Adjuster

- To adjust the compression damping force, turn the adjuster with a Allen wrench. Adjust the compression damping force to the standard setting position.

NOTICE

Do not force to turn the compression damping force adjuster from the fully seated position or the adjusting mechanism may be damaged.

Rear Shock Absorber

Spring Preload Adjustment

- Check the position of the spring preload adjuster above the muffler.

STD Spring Preload:

4 clicks (Clockwise from the fully seated position).

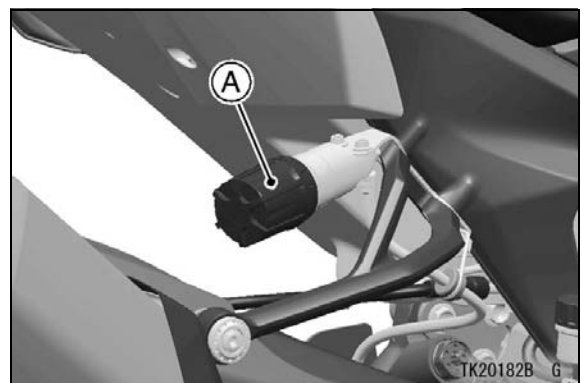

A. Spring Preload Adjuster

- To adjust the rear shock absorber spring preload, turn the adjuster. Adjust the spring preload to the standard setting position.

NOTICE

Do not force to turn the spring preload adjuster from the fully seated position or the adjusting mechanism may be damaged.

Rebound Damping Force Adjustment

- Check the position of the rebound damping force adjuster at the upper end of the rear shock absorber.

STD Rebound Damping Force:

13 clicks (Counterclockwise from the fully seated position).

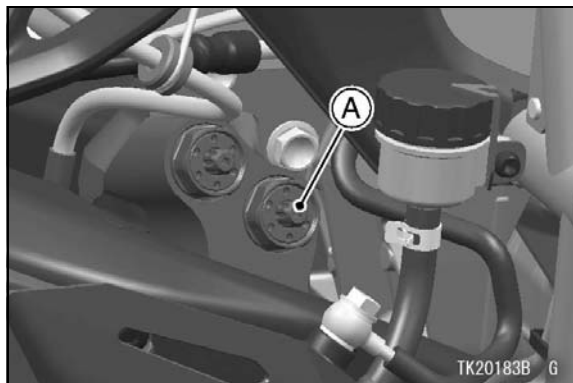

A. Rebound Damping Force Adjuster

- To adjust the rear shock absorber rebound damping force, turn the adjuster. Adjust the rebound damping force to the standard setting position.

NOTICE

Do not force to turn the rebound damping force adjuster from the fully seated position or the adjusting mechanism may be damaged.

Compression Damping Adjustment

- Check the position of the compression damping force adjuster at the upper end of the rear shock absorber.

STD Compression Damping Force:

15 clicks (Counterclockwise from the fully seated position)

- To adjust the compression damping force, turn the adjuster. Adjust the compression damping force to the standard setting position.

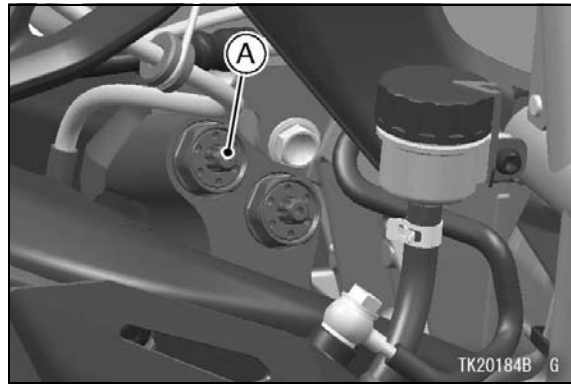

A. Compression Damping Adjuster

NOTICE

Do not force the compression damping force adjuster beyond the fully seated position, or the adjusting mechanism may be damaged.

Tire Air Pressures

- To prevent flat-spotting during shipment, the tires are over-inflated before crating. Adjust the pressures to the specified values in the front and rear, and make sure to tighten the caps securely.

Tire Air Pressure [when cold]:

Front: 250 kPa (2.50 kgf/cm², 36 psi)

Rear: 290 kPa (2.90 kgf/cm², 42 psi)

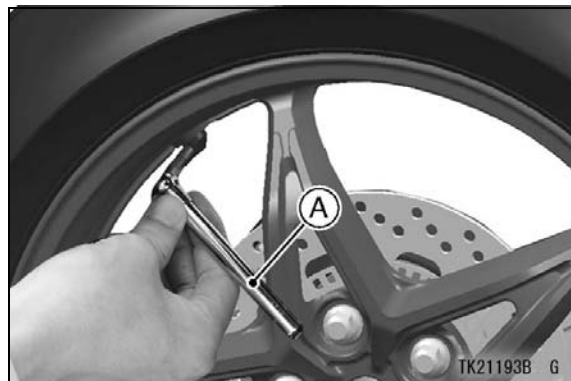

A. Tire Pressure Gauge

Fuel

⚠ WARNING

Gasoline is extremely flammable and can be explosive under certain conditions, creating the potential for serious burns. When filling the tank, turn the ignition switch off. Do not smoke. Make sure the area is well ventilated and free from any source of flame or sparks; this includes any appliance with a pilot light.

- Open the fuel tank cap, and check for debris in the fuel tank.
- Fill the fuel tank with one gallon or four liters of unleaded gasoline. Use a gasoline with a minimum octane rating shown below.

For US, Canada, California and Brazil Specifications

Fuel Type	Unleaded Gasoline	
Minimum Octane Rating	Antiknock Index	(RON + MON) 2
	90	

For Other than US, Canada, California and Brazil Specifications

Use clean, fresh unleaded gasoline with an octane rating equal to or higher than that shown in the table.

Fuel Type	Unleaded Gasoline
Minimum Octane Rating	Research Octane Number (RON) 95

- Close the fuel tank cap and check for any leaks.

Engine Oil (4-stroke)

Engine Oil Level Inspection

NOTE

○ *This vehicle's engine is filled with 10W-40 oil from the factory. DO NOT DRAIN and refill the crankcase before use. Check oil level and drain bolt tightness.*

Torque: 25 N·m (2.5 kgf·m, 18 ft·lb)

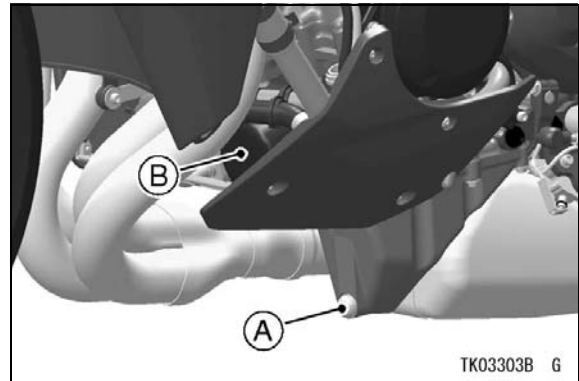

A. Engine Oil Drain Bolt

B. Oil Filter

- Park the vehicle on level ground.
- Before starting the engine, check that the engine has oil.
- With the motorcycle held level, check that the engine has oil through the oil level inspection window in the lower right side of the engine.

NOTICE

If the engine is run without oil, it will be severely damaged.

- Start the engine and run it for several minutes at idle speed. Stop the engine, then wait several minutes until the oil settles.
- With the motorcycle held level, check the engine oil level through the oil level inspection window. The oil level should come up between the upper and lower level lines next to the oil level inspection window.

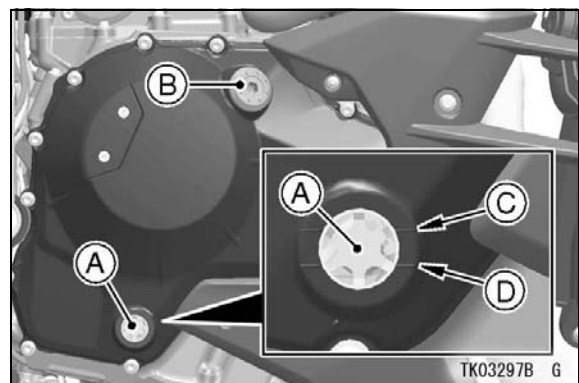

A. Oil Level Inspection Window

B. Oil Filler Cap

C. Upper Level Line

D. Lower Level Line

22 PREPARATION

- If the oil level is too high, remove the excess oil through the oil filler opening, using a syringe or some other suitable device.
- If the oil level is too low, add oil to reach the correct level. Use the same type of oil that is already in the engine.
- When replacing the cap, be sure the O-ring is in place, and tighten the cap to the specified torque.

Torque: 10 N·m (1.0 kgf·m, 89 in·lb)

Recommended Engine Oil

Type: API SG, SH, SJ, SL or SM with JASO MA, MA1 or MA2

Viscosity: SAE 10W-40

Capacity: 3.9 L (4.1 US qt)
[when filter is not removed]
4.4 L (4.7 US qt)
[when filter is removed]

NOTE

○ Do not add any chemical additive to the oil. Oils fulfilling the above requirements are fully formulated and provide adequate lubrication for both the engine and the clutch.

Although 10W-40 engine oil is the recommended oil for most conditions, the oil viscosity may need to be changed to accommodate atmospheric conditions in your riding area.

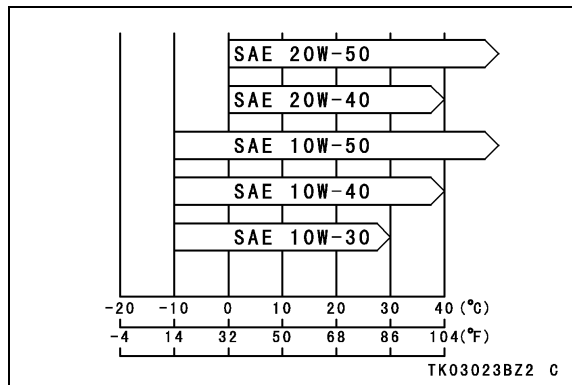

Throttle Grip and Cable

Throttle Grip Free Play Inspection

- Inspect the throttle grip free play. If the free play is incorrect, adjust the throttle cables.

Throttle Grip Free Play:

2 ~ 3 mm (0.08 ~ 0.12 in.)

- Check that the throttle grip moves smoothly from full open to close, and the throttle closes quickly and completely in all steering positions by the return spring. If the throttle grip does not return properly, check the throttle cable routing, grip free play, and for possible cable damage. Then lubricate the throttle cables.

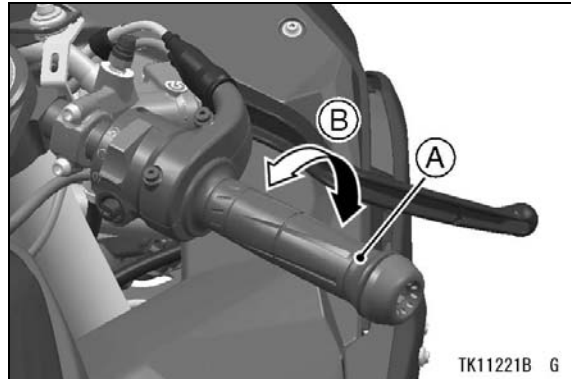

A. Throttle Grip

B. Throttle Grip Free Play

- Run the engine at idle speed, and turn the handlebars all the way to the right and left to ensure that the idle speed does not change. If the idle speed increases, check the throttle grip free play.

⚠ WARNING

Operation with incorrectly routed or improperly adjusted cables could result in an unsafe riding condition. Be sure the cables are routed correctly and properly adjusted.

Throttle Grip Free Play Adjustment

- Loosen both locknuts of the throttle cables and turn both adjusters in completely to give the throttle grip plenty of play.
- Turn out the decelerator cable adjuster until there is no play when the throttle grip is completely closed. Tighten the locknut.

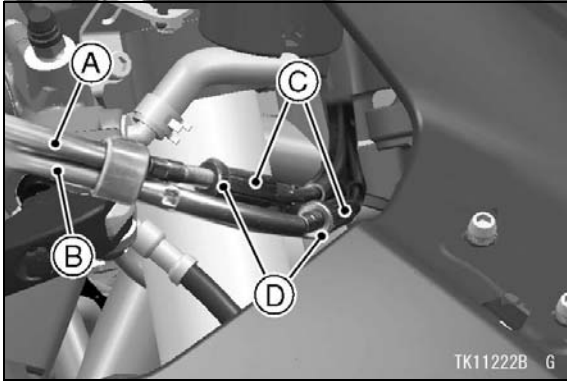

- A. Accelerator Cable
- B. Decelerator Cable
- C. Adjusters
- D. Locknuts

- Turn out the accelerator cable adjuster until the specified amount of play is obtained. Tighten the locknut.

Rear Brake Light Switch

Rear Brake Light Switch Adjustment

- Turn the ignition switch on. The brake light should illuminate when the brake pedal is depressed about 10 mm (0.39 in.)
- If it does not, turn the adjusting nut at the rear brake light switch as required.
- To adjust the rear brake light switch, move the switch up or down by turning the adjusting nut.

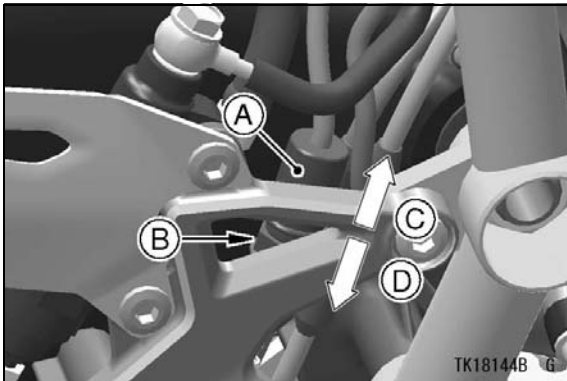

- A. Rear Brake Light Switch
- B. Adjusting Nut
- C. Lights sooner.
- D. Lights later.

NOTICE

To avoid damaging the electrical connections inside the switch, be sure that the switch body does not turn during adjustment.

Headlight Aim

The headlight beam is adjustable both horizontally and vertically. Headlight aim must be correctly adjusted for safe riding as well as on-coming drivers. In most areas it is illegal to ride with an improperly adjusted headlights.

Horizontal Adjustment

- Turn the horizontal adjuster in or out until the beam points straight ahead.

Vertical Adjustment

- Turn the vertical adjuster in or out to adjust the headlight vertically.

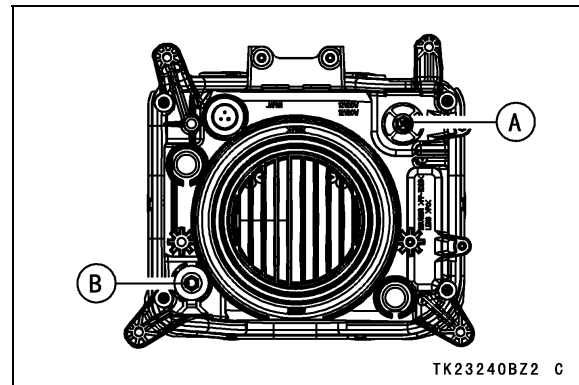

- A. Horizontal Adjusters
- B. Vertical Adjusters

For US and Canada Models

NOTE

- On high beam, the brightest point should be slightly below horizontal. The proper angle is 0.4 degrees below horizontal. This is a 50 mm (2.0 in.) drop at 7.6 m (25 ft) measured from the center of the headlight, with the motorcycle on its wheels and the rider seated.

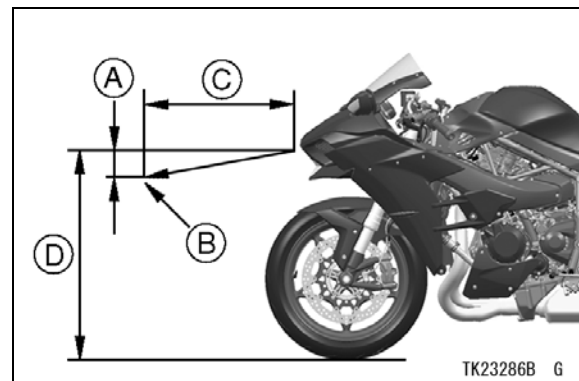

- A. 50 mm (2.0 in.)
- B. Center of Brightest Spot
- C. 7.6 m (25 ft)
- D. Height of Headlight Center

24 PREPARATION

For other than US and Canada Models

NOTE

- *On high beam, the brightest point should be slightly below horizontal with the motorcycle on its wheels and the rider seated. Adjust the headlight to the proper angle according to local regulation.*

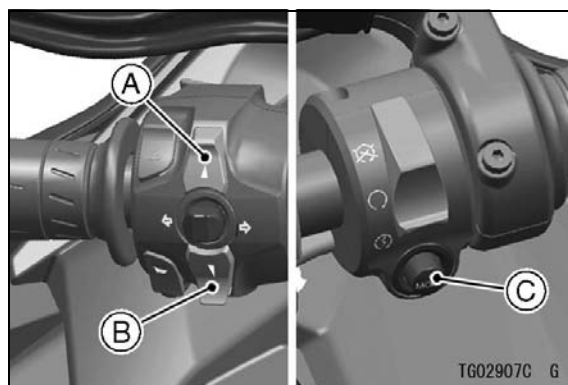
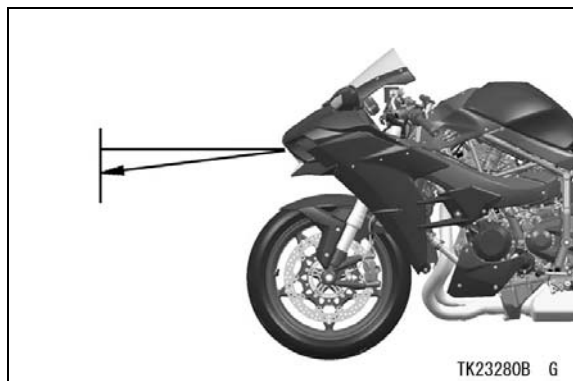

- A. Upper Button
- B. Lower Button
- C. Mode Button

Digital Meter

Check the Unit Setting: km/h, mph

Mph-km/h Display can alternate between English and metric modes (mph and km/h) on the digital meter. Make sure that mph or km/h is correctly displayed according to local regulations before sale.

NOTE

- *Do not operate the vehicle with the digital meter displaying the wrong unit (mph or km/h) of the digital meter. Shift the mph km/h display on the digital meter as follows.*
- *The unit setting can be selected from four unit types.*
 - Turn the ignition switch on.
 - Push and hold the mode button to shift to the setting mode.
 - Push the upper button or lower button to display the "UNIT." The setting modes can be shifted in the following order.

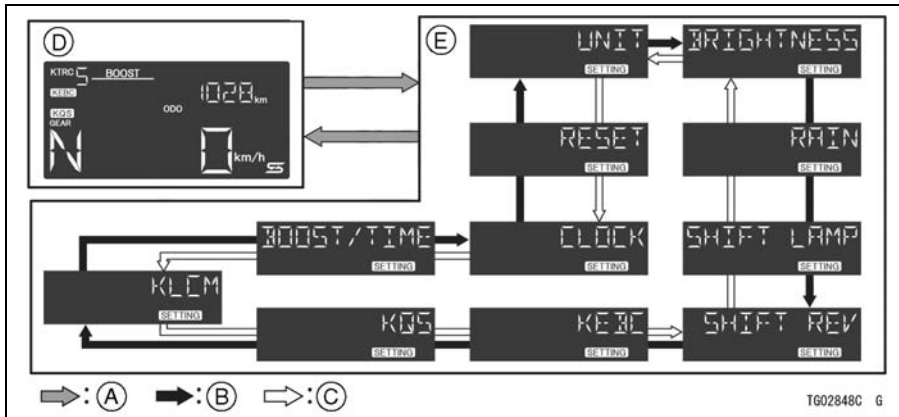

- A. Flow when pushing and holding mode button**
- B. Flow when pushing upper button**
- C. Flow when pushing lower button**
- D. Ordinary Display**
- E. Setting Mode**

- Push the mode button.
- Push the upper button or lower button to select the type.

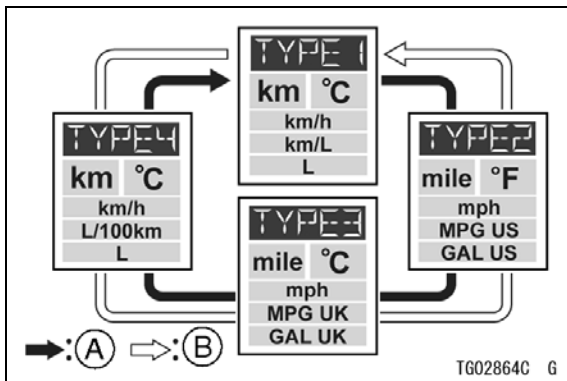

- A. Flow when pushing upper button**
- B. Flow when pushing lower button**

- Push the mode button.

Fastener Check

- The torque values listed are for assembly and preparation items only, see the appropriate Service Manual for a more comprehensive list. Check tightness of all fasteners that are in the table before retail delivery. Also check to see that each cotter pin or circlip is in place.

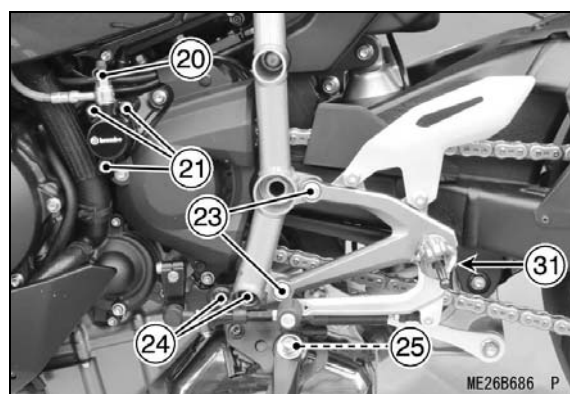
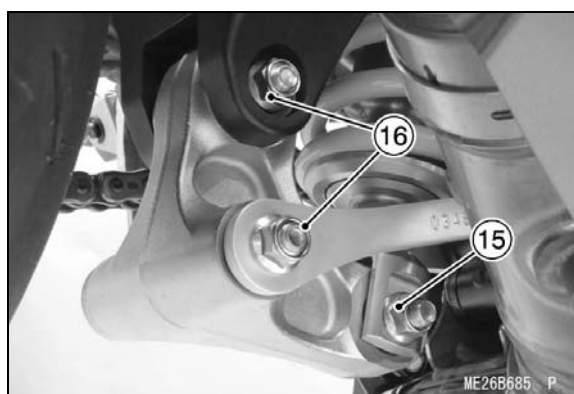
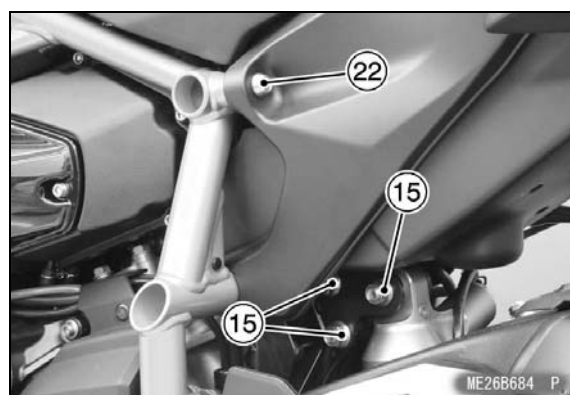
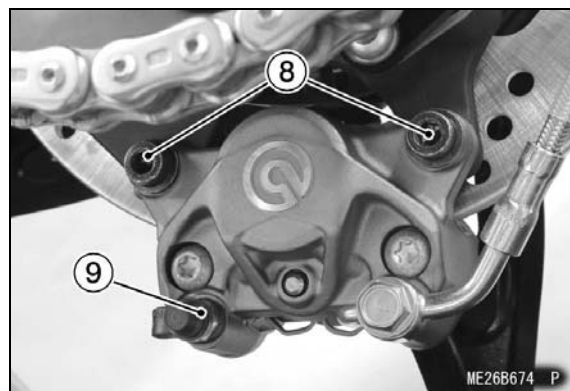
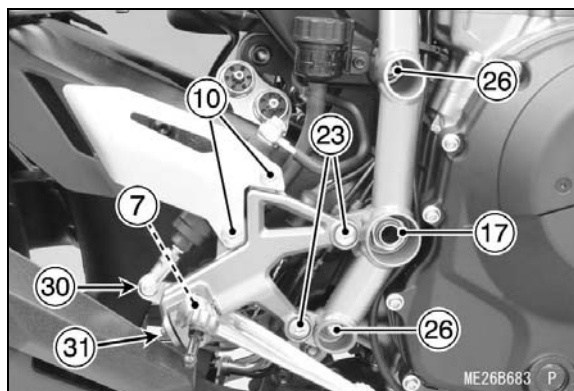
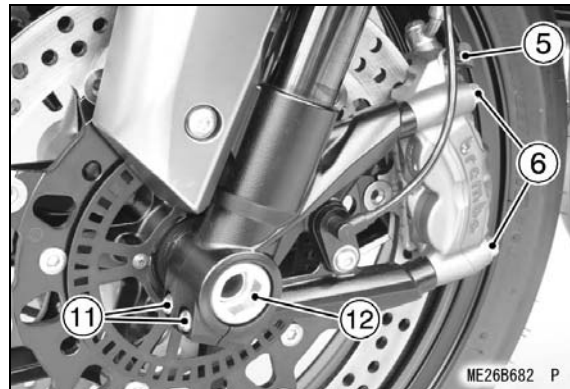
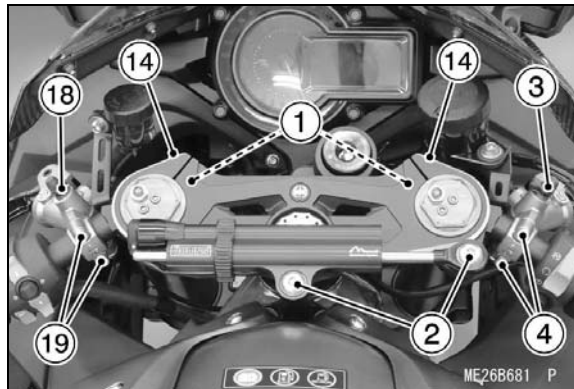

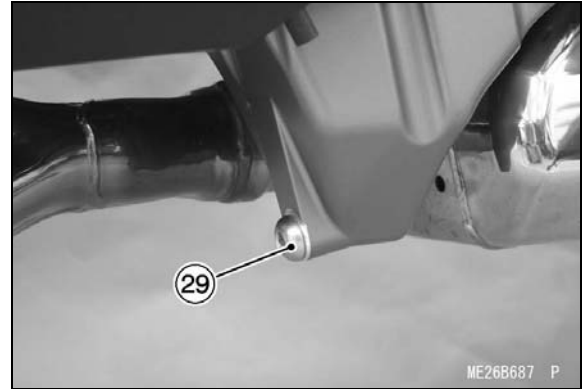
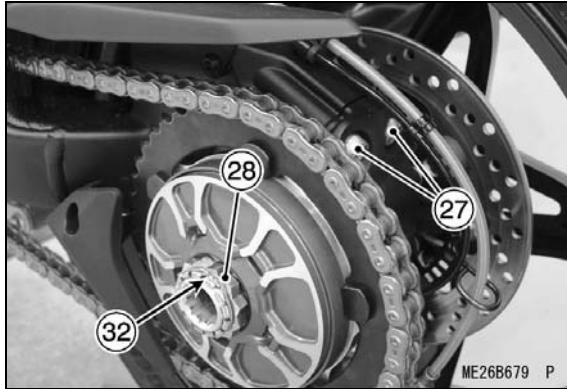

No.	Fastener	Torque			Remarks
		N·m	kgf·m	ft·lb	
Steering					
1	Handlebar clamp bolts	25	2.5	18	
2	Steering damper mounting bolts	11	1.1	97 in·lb	
Brakes					
3	Front master cylinder bleed valve	5.5	0.56	49 in·lb	
4	Front master cylinder clamp bolts	11	1.1	97 in·lb	
5	Front caliper bleed valve (left and right)	16	1.6	12	
6	Front caliper mounting bolts	34	3.5	2.5	
7	Brake pedal bolt	8.8	0.90	78 in·lb	
8	Rear caliper mounting bolts	27	2.8	20	
9	Rear caliper bleed valve	16	1.6	12	
10	Rear master cylinder mounting bolts	25	2.5	18	
Wheels/Tires					
11	Front axle clamp bolts	20	2.0	15	AL
12	Front axle nut	127	13.0	93.7	
13	Rear wheel nuts	110	11.2	81.1	
Suspension					
14	Upper front fork clamp bolts (left and right)	20	2.0	15	
15	Rear shock absorber nut/bracket nuts	34	3.5	25	
16	Rocker arm nut/tie-rod nut	34	3.5	25	
17	Swingarm pivot shaft nut	108	11.0	79.7	
Others					
18	Clutch master cylinder bleed valve	5.5	0.56	49 in·lb	
19	Clutch master cylinder clamp bolts	9.0	0.92	80 in·lb	
20	Clutch slave cylinder bleed valve	7.9	0.81	70 in·lb	
21	Clutch slave cylinder mounting bolts	10	1.0	89 in·lb	
22	Rear frame bracket bolts (left and right)	25	2.5	18	
23	Footpeg bracket bolts	25	2.5	18	
24	Side stand bracket bolts	49	5.0	36	
25	Side stand nut	36	3.7	27	

28 PREPARATION

No.	Fastener	Torque			Remarks
		N·m	kgf·m	ft·lb	
26	Swingarm mounting plate nut and bolt	44	4.5	32	
27	Bearing housing clamp bolts	33	3.4	24	AL
28	Rear axle nut	255	26.0	188	
Engine Oil Drain					
29	Engine oil drain bolt	25	2.5	18	
Cotter Pin or Circlip					
30	Rear master cylinder push rod cotter pin	–	–	–	
31	Footpeg pin circlip (Left and Right)	–	–	–	
32	Rear axle nut circlip	–	–	–	

AL: Tighten the two clamp bolts alternately two times to ensure even tightening torque.

Standard Torque Table

This table relating tightening torque to thread diameter, lists the basic torque for bolts and nuts. Use this table for only the bolts and nuts which do not require a specific torque value. All of the values are for use with dry solvent-cleaned threads.

General Fasteners

Threads dia. (mm)	Torque		
	N·m	kgf·m	ft·lb
5	3.4 ~ 4.9	0.35 ~ 0.50	30 ~ 43 in·lb
6	5.9 ~ 7.8	0.60 ~ 0.80	52 ~ 69 in·lb
8	14 ~ 19	1.4 ~ 1.9	10.0 ~ 13.5
10	25 ~ 34	2.6 ~ 3.5	19.0 ~ 25
12	44 ~ 61	4.5 ~ 6.2	33 ~ 45
14	73 ~ 98	7.4 ~ 10.0	54 ~ 72
16	115 ~ 155	11.5 ~ 16.0	83 ~ 115
18	165 ~ 225	17.0 ~ 23.0	125 ~ 165
20	225 ~ 325	23.0 ~ 33.0	165 ~ 240

Test Ride the Motorcycle

- Complete the test ride checklist.

NOTE

○ *Some noise from the super charger tensioner could occur when starting vehicle after long storage. However, if there is no problem on the function of the tensioner, that noise will disappear after riding for a while.*

Control Cables:

Throttle cables must work without binding in any steering position.

Steering:

Action is free from lock-to-lock.

Suspension:

Check operation front and rear.

Engine:

Electric starter works properly and engine starts promptly. Good throttle response and return.

Transmission and Clutch:

Smooth operation.

Brakes:

Adequate, smooth stopping power, No drag.

Digital Meter:

Check operation

Electrical System:

Headlight - check high and low beams.

Taillight - check operation.

Brake Light - check operation.

Turn Signal Lights - check operation.

Horn - check operation.

Instrument Lights and Indicator Lights -

Check operation.

Engine Stop Switch Works:

Starter Interlock Switch Works:

No Unusual Noises:

No Fuel, Oil, Brake Fluid, or Coolant Leaks:

PREPARATION COMPLETE.

⚠ WARNING

New tires are slippery and may cause loss of control and serious injury or death. A break-in period of 160 km (100 miles) is necessary to establish normal tire traction. During break-in, avoid sudden and maximum braking, acceleration, and hard cornering.

A & P Check List

- Complete the A & P Check List.

MODEL APPLICATION

Year	Model	Name
2017	ZX1000XH	Ninja H2